



LAND



SEA



AIR

SRP12

High efficiency, military-grade DC/DC Power supply



- MIL-STD-704 & MIL-STD-1275 Compliance
- To comply with MIL-STD-461 & DO-160
- 12-40V DC-In, 12V Output up to 12.5 Amp
- Input EMI filtering
- Over-current, over-voltage and over-temperature protection
- Design for reliability under demanding MIL-STD-810G Thermal, Shock, Vibration, Humidity/EMI/EMC conditions
- Operating temperature: -40 °C to +85 °C



- **Block Diagram**

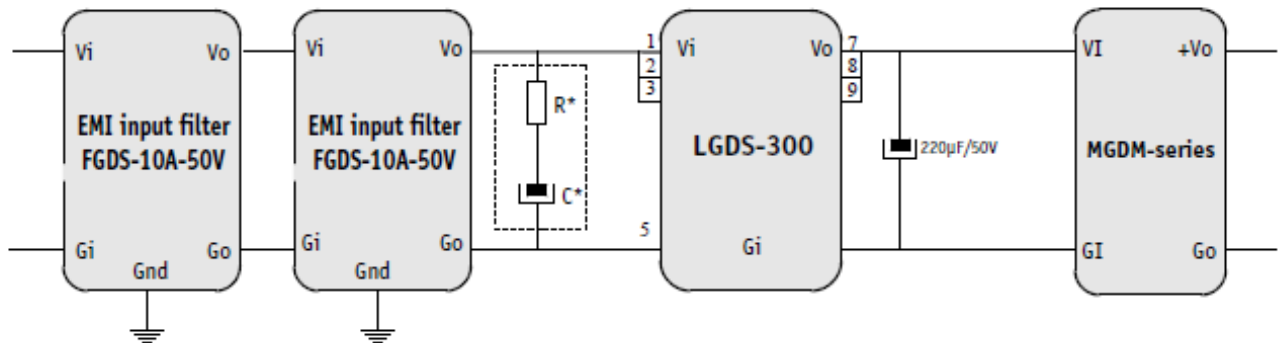

- **Features**

About EMI Filtering design :

The FGDS-10A-50V is a very compact and low loss solution for applications requiring up to 10A input current. The FGDS-10A-50V complies with major standards including :

- the US MIL-STD-461 rev D, E and rev F
- the international DO-160 rev C, D, E, F & rev G.

In particular, the filter module is compliant with the following requirements of MIL-STD-461D/E and DO-160-C/D/E standards :

- MIL-STD-461D/E/F Part 2. & 3. requirements :
- Conducted Emission (CE)
- CE102, power leads, emission over 10KHz to 10MHz, basic curve
- Conducted Susceptibility (CS)
- CS101, power leads, frequency 30Hz to 150KHz, curve #1,
- CS114, bulk cable injection, frequency 10KHz to 400MHz,
- CS115, spikes, bulk cable injection calibrated spike
- CS116, damped sinusoidal transient
- DO-160-C/D/E/F/G requirements :
- Conducted Emission (CE)
- Section 21 power lines, emission over 15KHz to 152MHz, category B, AZ & LMH
- Conducted Susceptibility (CS)
- Section 20 power lines, frequency 10KHz to 400MHz

In addition, this filter withstands in a transparent state without damage the transient requirements of :

- MIL-STD-704A/D/E/F with up to 80V/100ms
- MIL-STD-1275A/B/C/D with up to 100V/50ms

The FGDS-10A-50V is suitable for all GAIA Converter DC/DC converters and DC architecture

- from 25W up to 150W output power
- up to 10A output current
- up to 50V permanent input voltage.

About Transient Protection design :

The Module features 3 modes of operations as follow:

- Normal operation

Normal operation occurs in between the permanent input voltage of the DC/DC converter;
The LGDS-300 is then operating in steady transparency state.

- Power fail operation

The power fail operation occurs when the input bus drops below 9 Vdc low voltage limit ; an undervoltage lock-out stops the LGDS-300.

Transient

O : 100V/50ms

- Transient operation

The LGDS-300 clamps input transient up to 80V/100ms or 100V/50ms.

The LGDS-300 series is compliant with the international input bus standards :

- MIL-STD-704A/D/E/F
- AECMA EN2282
- GAM-EG13B/AIR2021E
- DO160E cat A, B and Z
- MIL-STD-1275A/B/C/D

About DC/DC :

- Ultra wide input range 12-40 Vd
- 28Vdc input compliant with MIL-STD-704A/D/
- Industry standard quarter brick packag
- Power up to 150
- Wide temperature range : -40/+85°C baseplat
- High efficiency (typ. 86%-90%)
- Soft star
- Galvanic isolation 1 500 VD
- Integrated LC EMI filte
- Synchronizabl
- Fully protected by independant securit
- Under voltage lock-ou
- Overvoltage protectio
- Current limitation protectio
- Overtemperature protectio
- No optocoupler for high reliabilit



- **Module Compliance with MIL-STD-461C/D/E Standards**

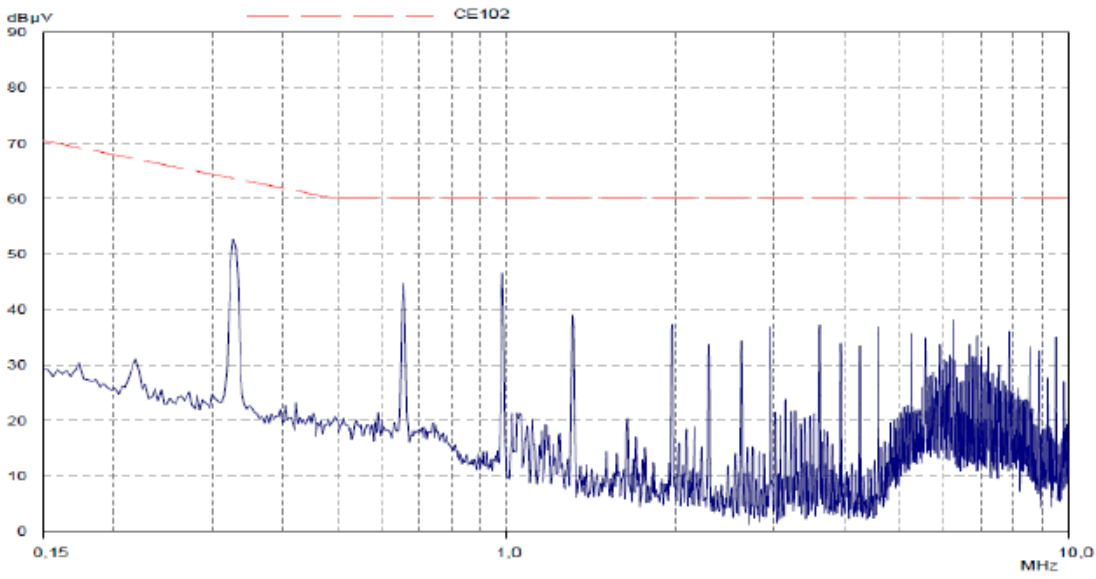

MIL-STD-461E : MGDS-15x-H-J with FGDS-10A-50V

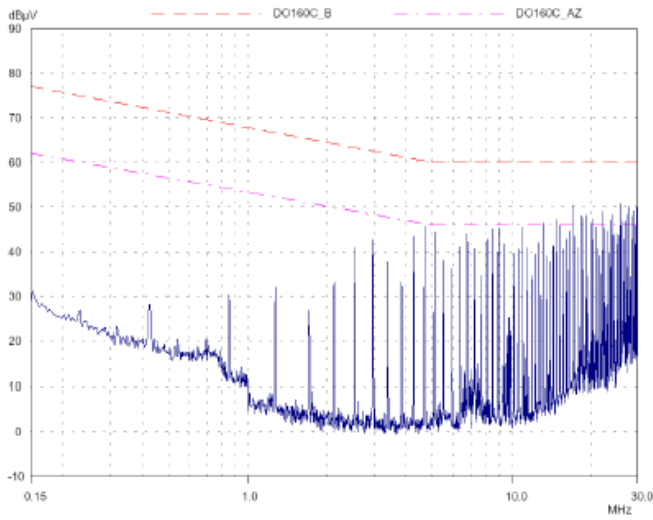

DO-160G : MGDS-15x-H-J with FGDS-10A-50V

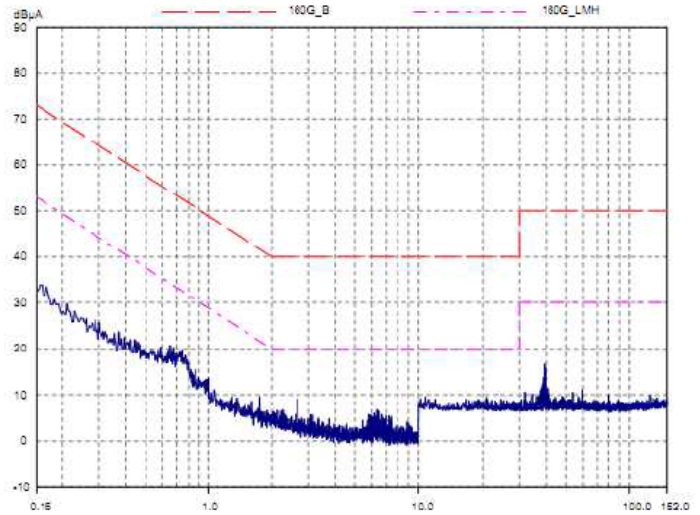

Specifications

SPECIFICATIONS	
Voltage Input	12Vdc to 40Vdc 28Vdc input compliant with MIL-STD-704A/D/F
Voltage Output	150W, 12V @ 12.5 A Ps. (Input 12V, workable with derating 114W)
Performance Characteristic	Ripple: <300m Line Regulation: <100 mV Load Regulation: <100 mV Efficiency: (typ. 86%-90%)
PHYSICAL	
Dimension (W x D x H)	165 x 260 x 94mm
Weight	2.8 Kg (6.17lbs)
Chassis	Aluminum Alloy, Corrosion Resistant.
Finish	Anodic aluminum oxide (Color Iron gray)
Cooling	Natural Passive Convection/Conduction. No Moving Parts
Ingress Protection	IP65
Connector Type	Amphenol TV07RW-11-54P
ENVIRONMENTAL	
MIL-STD-810G TEST	Method 507.5, Procedure II (Temperature & Humidity) Method 516.6 Shock-Procedure V Non-Operating (Mechanical Shock) Method 516.6 Shock-Procedure I Operating (Mechanical Shock) Method 514.6 Vibration Category 24/Non-Operating (Category 20 & 24, Vibration) Method 514.6 Vibration Category 20/Operating (Category 20 & 24, Vibration) Method 501.5, Procedure I (Storage/High Temperature) Method 501.5, Procedure II (Operation/High Temperature) Method 502.5, Procedure I (Storage/Low Temperature) Method 502.5, Procedure II (Operation/Low Temperature) Method 503.5, Procedure I (Temperature shock)
Reliability	No Moving Parts; Passive Cooling Designed & Manufactured using ISO 9001/2000 Certified Quality Program
EMC Compliance	To comply with MIL-STD-461D/E/F power leads : CE 102 : Emission requirement over 10 KHz to 10MHz CS 101 : Susceptibility requirement over 30Hz to 150KHz CS 114 : Susceptibility requirement over 10KHz to 400MHz CS 115 : Susceptibility requirement for spikes To comply with DO-160C/D/E/F/G power lines : Conducted emission requirement over 15 KHz to 152MHz Conducted susceptibility requirement over 10Hz to 400MHz EN61000-6-2 & EN61000-6-4
Operating Temperature	-40 to 85°C
Storage Temperature	-40 to 85°C

DIMENSIONS

