

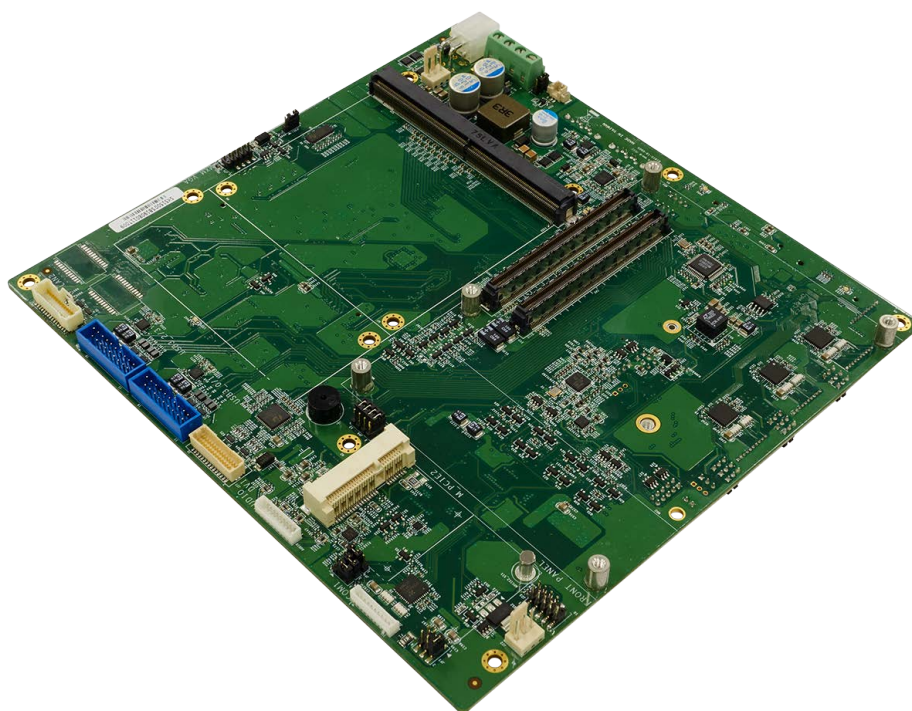

# SK515

COM Express® Type 6 Carrier Board  
+ MXM Graphics System + PCIe/104



## Safety information

### Electrical safety

- To prevent electrical shock hazard, disconnect the power cable from the electrical outlet before relocating the system.
- When adding or removing devices to or from the system, ensure that the power cables for the devices are unplugged before the signal cables are connected. If possible, disconnect all power cables from the existing system before you add a device.
- Before connecting or removing signal cables from the motherboard, ensure that all power cables are unplugged.
- Seek professional assistance before using an adapter or extension cord. These devices could interrupt the grounding circuit.
- Make sure that your power supply is set to the correct voltage in your area.
- If you are not sure about the voltage of the electrical outlet you are using, contact your local power company.
- If the power supply is broken, do not try to fix it by yourself. Contact a qualified service technician or your local distributor.

### Operation safety

- Before installing the motherboard and adding devices on it, carefully read all the manuals that came with the package.
- Before using the product, make sure all cables are correctly connected and the power cables are not damaged. If you detect any damage, contact your dealer immediately.
- To avoid short circuits, keep paper clips, screws, and staples away from connectors, slots, sockets and circuitry.
- Avoid dust, humidity, and temperature extremes. Do not place the product in any area where it may become wet.
- Place the product on a stable surface.
- If you encounter any technical problems with the product, contact your local distributor

### Statement

- All rights reserved. No part of this publication may be reproduced in any form or by any means, without prior written permission from the publisher.
- All trademarks are the properties of the respective owners.
- All product specifications are subject to change without prior notice

## Revision History

Revision	Date (yyyy/mm/dd)	Changes
V1.0	2019/11/1	Initial release

## Packing list

- COM Express + MXM carrier board
- Accessories

Item	Description	Q'ty
1	Driver CD	1
2	Screw for fixing COM Express/ MXM module	7



If any of the above items is damaged or missing, please contact your local distributor.

## Ordering information

Model Number	Description
SK515	COM Express Type 6 carrier board w/PCIe104, MXM, 9~36V DC-in, operating Temp -40 to 85°C

## Table Contents

<b>SAFETY INFORMATION</b> .....	<b>1</b>
ELECTRICAL SAFETY .....	1
OPERATION SAFETY .....	1
STATEMENT.....	1
<b>REVISION HISTORY</b> .....	<b>2</b>
<b>PACKING LIST</b> .....	<b>2</b>
<b>ORDERING INFORMATION</b> .....	<b>2</b>
<b>TABLE CONTENTS</b> .....	<b>3</b>
<b>CHAPTER 1: PRODUCT INTRODUCTION</b> .....	<b>5</b>
1.1 KEY FEATURES.....	5
1.2 BLOCK DIAGRAM .....	6
1.3 GPU OPTIONS .....	7
1.4 CONNECTOR & PIN HEADER .....	8
<b>CHAPTER 2: JUMPERS AND CONNECTORS</b> .....	<b>9</b>
2.1 CONNECTOR & PIN DEFINITIONS .....	9
J26 (COM1) .....	9
AUDIO1 (Line-Out/MIC).....	9
JUSB3_1 (USB3.0).....	9
JUSB3_2 (USB 3.0).....	10
J27(DVI) .....	10
JP7 (COM1 Pin9 select).....	10
JP8, JP9 (COM1 Mode select) .....	10
JP10 (Enable COM1 RS-485/422 Receiver Termination).....	11
J22, J25 (FAN Connector).....	11
J23 (Front Panel) .....	11
CN1,CN2 (COM Express Connector) .....	12
CN15 (M_PCIE2 (mini PCIe Slot)) .....	12
JP6 (miniPCIe1 function select).....	12
J20 (MXM_VGA).....	12
JP30 (MXM Type select) .....	12
MXM1 (MXM socket) .....	12
CN21 (MXM DC-IN) .....	13
JP28 (Clear CMOS).....	13
DCIN (System DC-IN) .....	13
LAN1 (LAN1/LAN2).....	13
J18 (MXM_DP(C/D)).....	14
J17 (MXM_DP(A/B)) .....	14
J10 (LVDS) .....	14
SIM_CARD1 (SIM Card).....	14
JUSB2 (USB4/USB5) .....	15
J8 (VGA).....	15
J9 (DIO).....	15
J11 (LVDS Backlight) .....	15
JP23 (LVDS Backlight Power select) .....	16
JP24 (LVDS Signal Power select).....	16
J4 (LPC) .....	16
J5: COM2 / J6: COM3 / J13: COM4.....	17
JP12, JP13 (COM2 Mode select).....	17
JP14 (Enable COM2 RS-485/422 Receiver Termination).....	17
JP11 (COM2 Pin9 select).....	17

JP16, JP17 (COM3 Mode select).....	17
JP18 (Enable COM3 RS-485/422 Receiver Termination).....	17
JP15 (COM3 Pin9 select) .....	18
JP20, JP21 (COM4 Mode select).....	18
JP22 (Enable COM4 RS-485/422 Receiver Termination).....	18
JP19 (COM4 Pin9 select).....	18
CN26, CN27 (SATA) .....	18
J2, J3 (SATA Power).....	18
CN14 (M_PCIE1 (mini PCIe Slot)) .....	19
CN3 (M.2 (2280 M key, SATA only)) .....	19
CN36 (StackPC1).....	19-20

## Chapter 1: Product Introduction

### 1.1 Key Features

#### COM Express CPU Options(Type6)

	CPU		SPEC
9th CPU	Intel® Xeon® E-2276M	45W	Coffee Lake 9th Gen, 6 x 2.8 / 4.7 GHz, 12MB cache
9th CPU	Intel® Core™ i7-9850EQ	45W	Coffee Lake 9th Gen, 6 x 2.7 / 4.4 GHz, 9MB cache
9th CPU	Intel® Core™ i7-9850HE	45W	Coffee Lake 9th Gen, 6 x 2.7 / 4.4 GHz, 9MB cache
7th CPU	Intel® Core™ i7-7820EQ	45W	Kaby Lake 7th Gen, 4 x 3.0 / 3.7 GHz, 8MB cache
6th CPU	Intel® Core™ i7-6822EQ	25W	Sky Lake 6th Gen, 4 x 2.0 / 2.8 GHz, 8MB cache
6th CPU	Intel® Core™ i7-6820EQ	25W	Sky Lake 6th Gen, 4 x 2.0 / 2.8 GHz, 8MB cache
6th CPU	Intel® Xeon® E3-1505M v6	45W	Kaby Lake 6th Gen, 4 x 3.0 / 4.0 GHz, 8MB cache
6th CPU	Intel® Xeon® E3-1505L v6	25W	Kaby Lake 6th Gen, 4 x 2.2 / 3.0 GHz, 8MB cache

#### COM Express CPU Options(Type7)

	CPU		SPEC
Intel® Xeon® D	Express-BD7-D1559	45 W	Basic COM Express Type7 module with Intel Broadwell-DE D1559, 12C (eTEMP)
Intel® Xeon® D	Express-BD7-D1539	35 W	Basic COM Express Type7 module with Intel Broadwell-DE D1539, 8C (eTEMP)
Intel® Pentium®	Express-BD7-D1519	25 W	Basic COM Express Type7 module with Intel Broadwell-DE D1519, 4C (eTEMP)
Intel® Xeon® D	Express-BD7-D1577	45 W	Basic COM Express Type7 module with Intel Broadwell-DE D1577, 16C
Intel® Xeon® D	Express-BD7-D1548	45 W	Basic COM Express Type7 module with Intel Broadwell-DE D1548, 8C
Intel® Xeon® D	Express-BD7-D1527	35 W	Basic COM Express Type7 module with Intel Broadwell-DE D1527, 4C
Intel® Pentium®	Express-BD7-D1508	25 W	Basic COM Express Type7 module with Intel Broadwell-DE D1508, 2C

GPU Module Options	NVIDIA® GeForce™ GTX 950M – (Maxwell, 640 CUDA Cores, 55W) NVIDIA® GeForce™ GTX 1050 – (Pascal, 640 CUDA Cores, 50W) NVIDIA® GeForce™ GTX 1050Ti – (Pascal, 768 CUDA Cores, 60W) NVIDIA® GeForce™ GTX 1060M – (Pascal, 1280 CUDA Cores, 80W) NVIDIA® GeForce™ GTX 1070M – (Pascal, 2048 CUDA Cores, 120W) NVIDIA® GeForce™ GTX 1080M – (Pascal, 2560 CUDA Cores, 150W)
COM Express Compatibility	COM Express® Type-6
MiniPCIe Expansion	2 x Full-size mini PCIe (1 with mSATA supported)
M.2 Expansion	1 x 2280 M key (SATA only)
PCIe/104 Expansion	4 x PCIe x 1 1 x PCIe x 4 5 x USB 2.0 1 x LPC 1 x SPI
DisplayPort	2 x DisplayPort outputs from COM Express®, 4 x outputs from GPU, 6 total
VGA	1 x output from COM Express®, 1 x output from GPU
LVDS	1 x dual channel 18/24-bit LVDS
Gigabit Ethernet	2 x 10/100/1000 Ethernet Ports
USB	4 x USB 3.0, 2 x USB 2.0
Audio	1 x Line-out, 1 x MIC-In
COM Port	4 x RS232/422/485 (function select by jumper)
Input Power_SYS	9~36V (4P Terminal Block)
Input Power_MXM	12V (ATX 4P)
Power Consumption	Varies per COM Express /MXM with different CPU and GPU models
RTC Battery	3V CR2032
Dimensions	190 x 185 mm
Operating Temperature Range	-40 to 85°C
Storage Temp.	-40 to 85°C
Relative Humidity	10% to 90%, non-condensing

## 1.2 Block Diagram

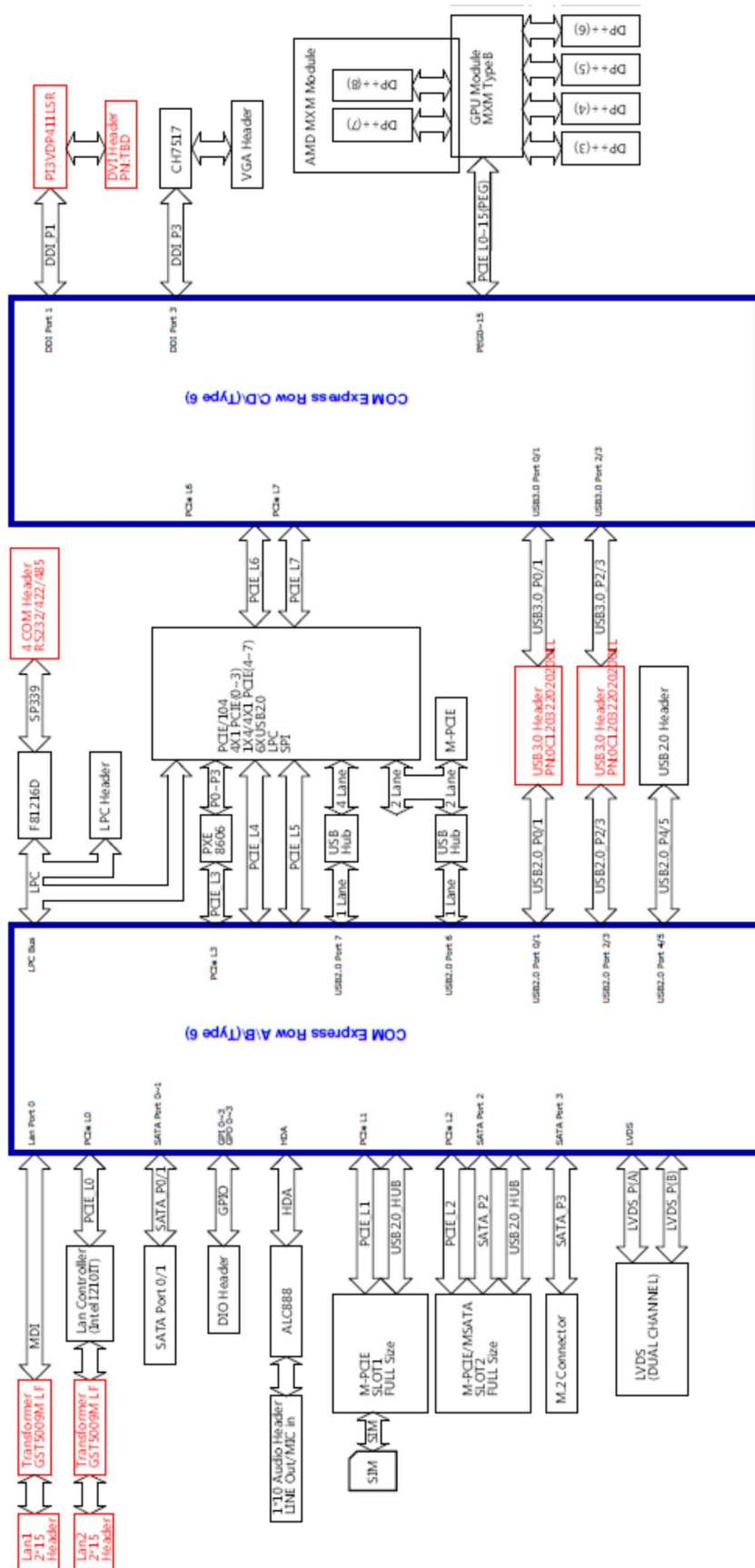



### 1.3 Connector & pin header

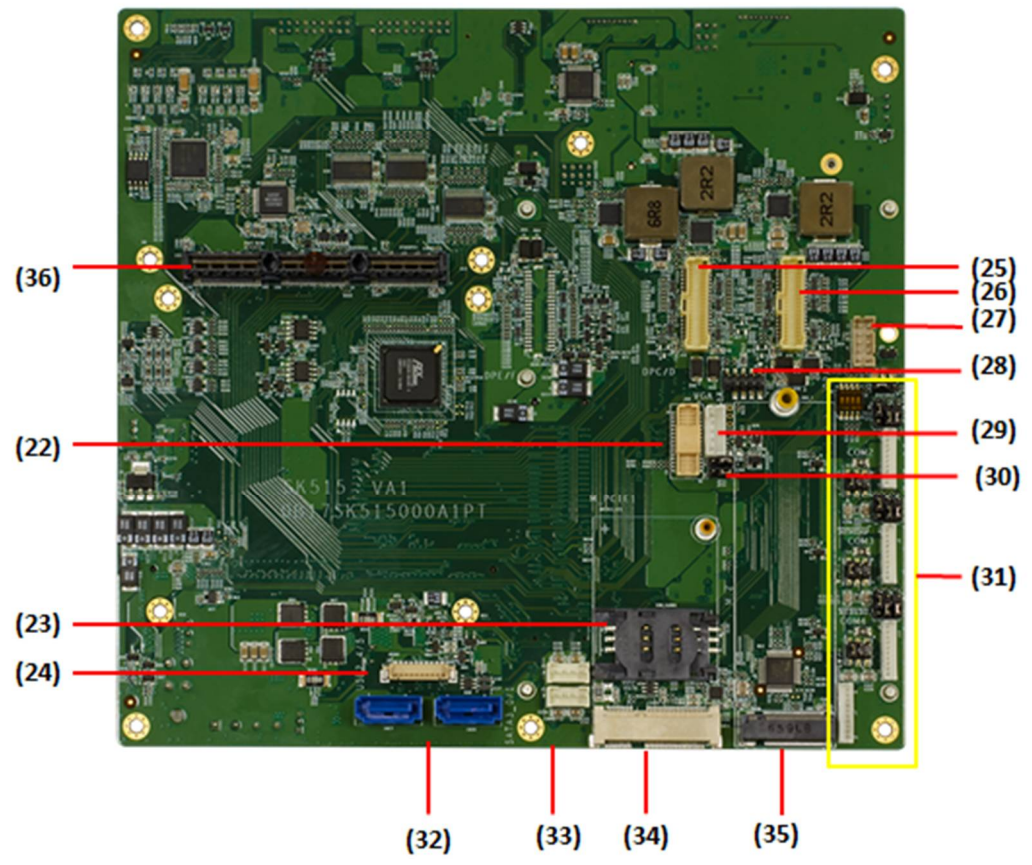
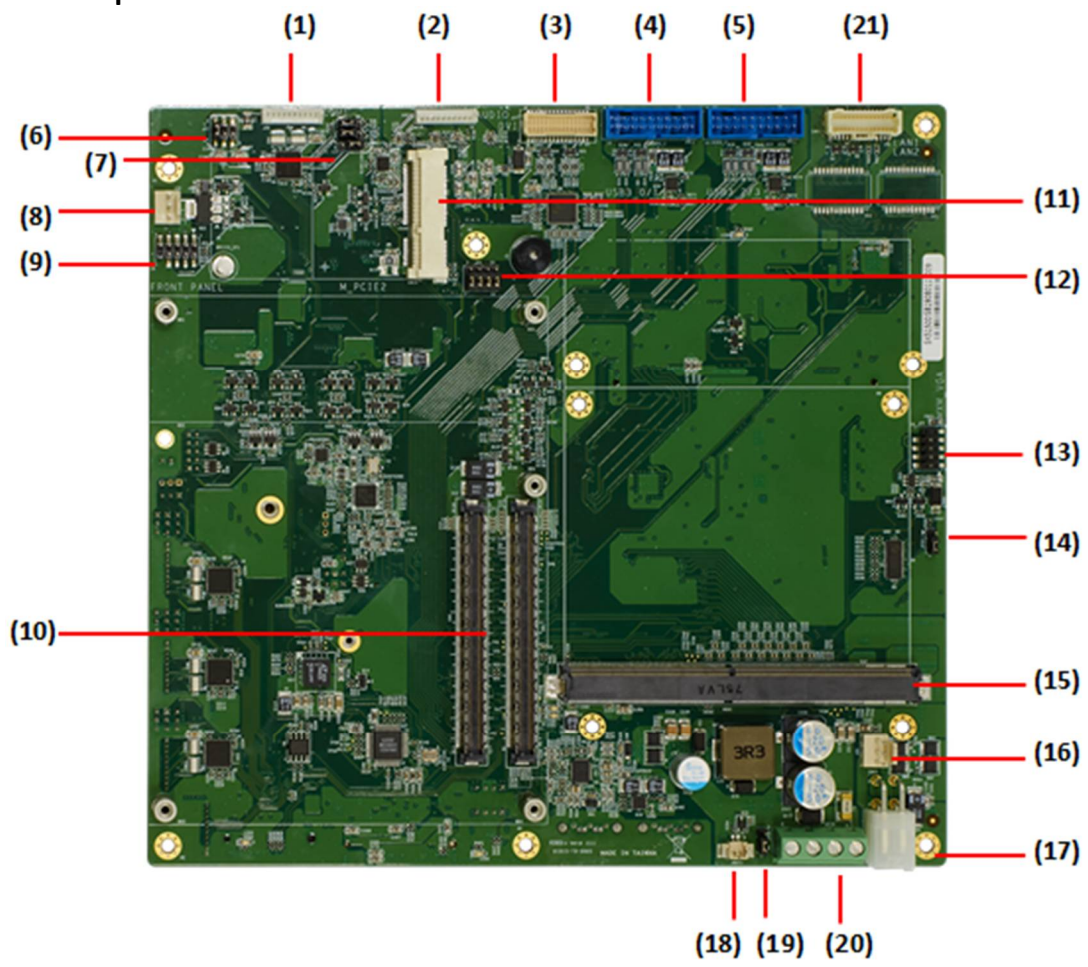

1	J26
2	AUDIO (MIC-In/LINE-Out)
3	J27
4	JUSB3_1
5	JUSB3_2
6	JP7
7	JP8,JP9,JP10
8	J22
9	J23
10	CN1, CN2 (COM Express connector)
11	CN15 (miniPCle)
12	JP6
13	J20
14	JP30
15	MXM1
16	J25
17	CN21
18	JBAT1
19	JP28
20	DCIN
21	LAN1 (LAN1/LAN2)
22	J10
23	SIM_CARD1
24	JUSB2
25	J18 (DPC/D)
26	J17 (DPA/B)
27	J9
28	J8
29	J11
30	JP23, JP24
31	See page 8~9
32	CN26, CN27
33	J2, J3
34	CN14
35	CN3
36	STACKPC1

## Chapter 2: Jumpers and Connectors

### 2.1 Connector & Pin Definitions

#### J26: COM1

Pin	RS232	RS422	RS485
1	5V	NC	NC
2	GND	GND	GND
3	COM_P9	NC	NC
4	DTR-	RX-	Data-
5	CTS-	NC	NC
6	TXD	RX+	Data+
7	RTS-	NC	NC
8	RXD	TX+	NC
9	DSR-	NC	NC
10	DCD-	TX-	NC

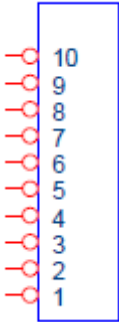

#### AUDIO

Pin	Function
1	GND
2	MIC_JD
3	MIC_R
4	MIC_L
5	FRONT_JD
6	FRONT_R
7	FRONT_L
8	N/C
9	N/C
10	N/C

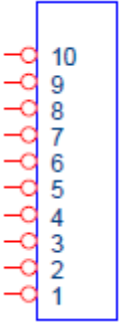

#### JUSB3\_1: USB 3.0 Port

Pin	Function	Pin	Function
1	+5V_USB0	11	USB2_DP1
2	USB3_RXN0	12	USB2_DN1
3	USB3_RXP0	13	GND
4	GND	14	USB3_TXP1
5	USB3_TXN0	15	USB3_TXN1
6	USB3_TXP0	16	GND
7	GND	17	USB3_RXP1
8	USB2_DN0	18	USB3_RXN1
9	USB2_DP0	19	+5V_USB1
10	N/C		

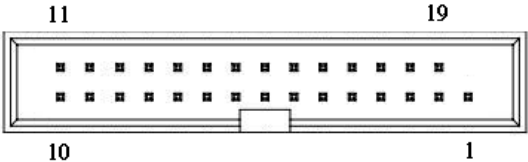

### JUSB3\_2: USB 3.0 Port

Pin	Function	Pin	Function
1	+5V_USB2	11	USB2_DP3
2	USB3_RXN2	12	USB2_DN3
3	USB3_RXP2	13	GND
4	GND	14	USB3_TXP3
5	USB3_TXN2	15	USB3_TXN3
6	USB3_TXP2	16	GND
7	GND	17	USB3_RXP3
8	USB2_DN2	18	USB3_RXN3
9	USB2_DP2	19	+5V_USB3
10	N/C		

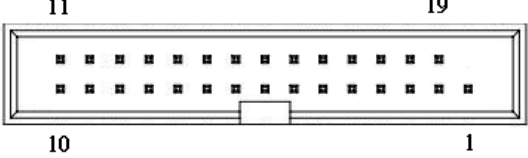

### J27: DVI

Pin	Function	Pin	Function	Pin	Function
1	VCC5	11	TMDS0_DATA1-	21	GND
2	GND	12	N/C	22	N/C
3	GND	13	TMDS0_DATA1+	23	TMDS0_CLK
4	TMDS0_SCL	14	N/C	24	N/C
5	TMDS0_DATA2-	15	GND	25	TMDS0_CLK+
6	TMDS0_SDA	16	N/C	26	N/C
7	TMDS0_DATA2+	17	TMDS0_DATA0-	27	GND
8	GND	18	N/C	28	N/C
9	GND	19	TMDS0_DATA0+	29	N/C
10	TMDS0_HPD	20	N/C	30	N/C



### JP7: COM1 Pin9 select

Pin	Function
(1-2) Closed	RI
(3-4) Closed	+5V
(5-6) Closed	+12V

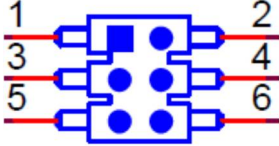

### JP8, JP9: COM1 Mode select

JP8	JP9	Mode
(2-3)	(2-3)	RS232
(1-2)	(2-3)	RS485 Half Duplex
(1-2)	(1-2)	RS485/422 Full Duplex

**JP10: Enable COM1 RS-485/422 Receiver Termination**

Pin	Function
(1-2) Closed	High
(2-3) Closed	Low

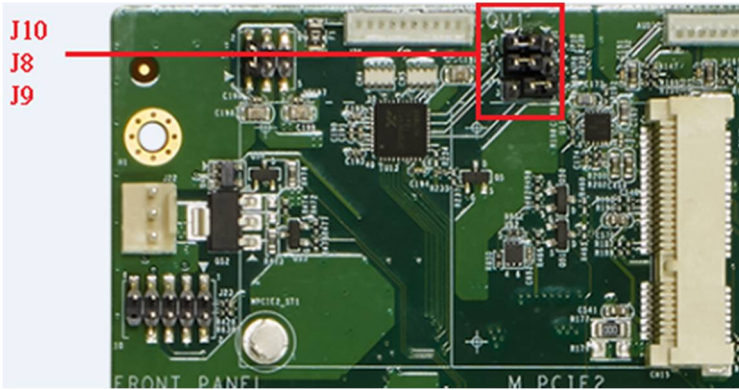

**J22: CPU FAN Connector**

Pin	Function
1	GND
2	CPUFANOUT
3	+12V

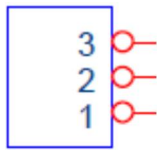

**J25: MXM FAN connector**

Pin	Function
1	GND
2	
3	+12V

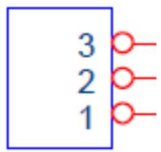

**J23: Front Panel**

Pin	Function
1	HDLED+
2	PWLED+
3	HDLED-
4	GND
5	GND
6	PWRBTN#
7	RESET
8	GND
9	NC

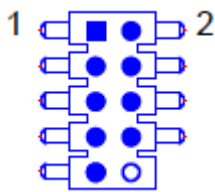

**CN1,CN2: COM Express Connector**

Support COM Express Basic Size Type 6 Module

**CN15: M\_PCIE2 (mini PCIe Slot)**

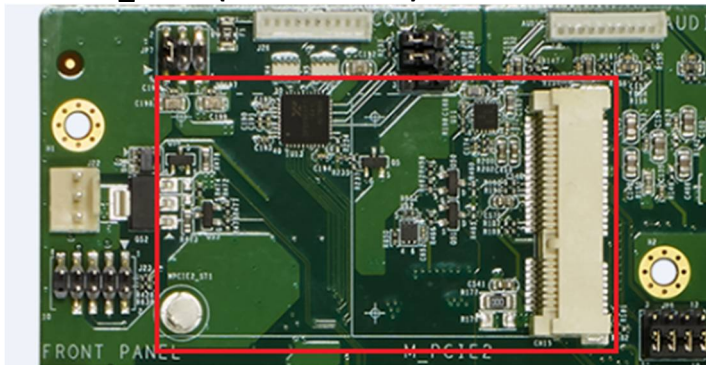

**JP6: miniPCIe1 function select**

PClex1	SATA	
(1-2) Closed	(2-3) Closed	

**J20: MXM\_VGA**

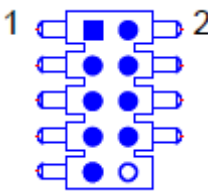
Pin	Function	
1	MVGA_VS	
2	MVGA_SCL	
3	MVGA_HS	
4	MVGA_SDA	
5	GND	
6	MVGA_VCC	
7	MVGA_R	
8	MVGA_B	
9	MVGA_G	

**JP30: MXM Type select**

Pin	Function
(1-2) Closed	MXM v3.0
(2-3) Closed	MXM v3.1

**MXM1: MXM socket**



### CN21: MXM DC-IN

Pin	Definition
1	12V
2	12V
3	GND
4	GND

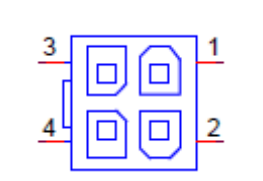

### JP28: Clear CMOS

Pin	Function
(1-2) Closed	Normal(default)
(3-4) Closed	Clear CMOS

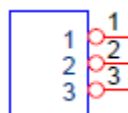

### DCIN: System DC-IN

Pin	Definition
1	12V
2	12V
3	GND
4	GND



### LAN1: LAN1/LAN2

Pin	Function	Pin	Function	Pin	Function
1	MDI2_0PX	12	MDI1_2NX	23	3V3SB
2	MDI1_0PX	13	MDI2_3PX	24	3V3SB
3	MDI2_0NX	14	MDI1_3PX	25	LAN2_LED_100#
4	MDI1_0NX	15	MDI2_3NX	26	GBE_LED_100-
5	MDI2_1PX	16	MDI1_3NX	27	LAN2_LED_1000#
6	MDI1_1PX	17	GND	28	GBE_LED_1000-
7	MDI2_1NX	18	GND	29	GND
8	MDI1_1NX	19	VCC_1V5	30	GND
9	MDI2_2PX	20	GB0_CTREF	31	GND
10	MDI1_2PX	21	LAN2_LED_ACT#	32	GND
11	MDI2_2NX	22	GBE_ACT-		

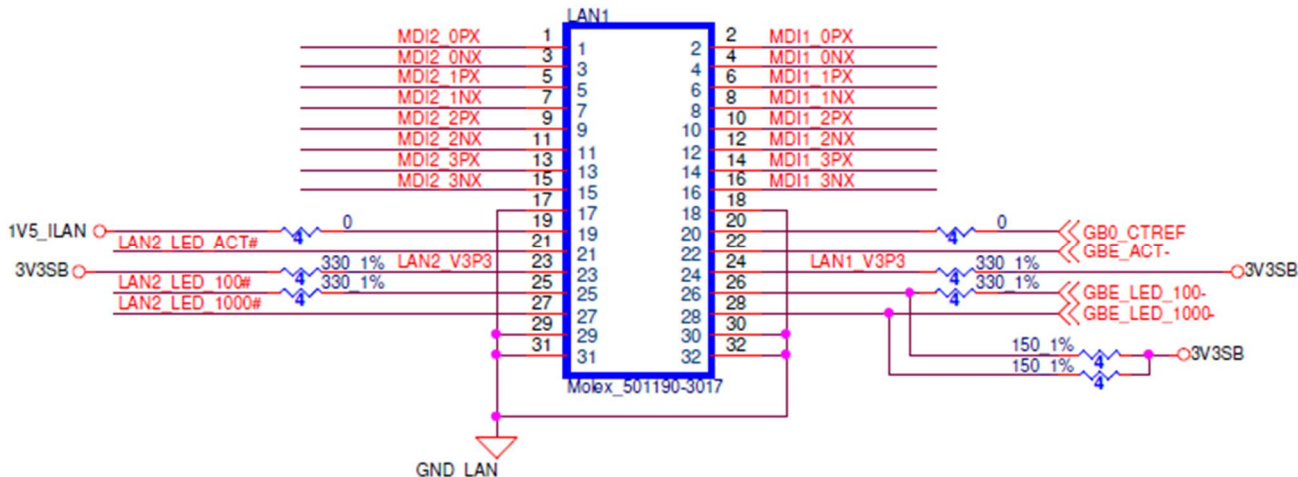
### J18: MXM\_DP(C/D)

Pin	Function	Pin	Function	Pin	Function	Pin	Function
1	GND	11	DPC_TN1	21	DPC_TP3	31	DPC_AUXP_CLK
2	GND	12	DPD_TN1	22	DPD_TP3	32	DPD_AUXP_CLK
3	DPC_TP0	13	GND	23	DPC_TN3	33	DPC_AUXN_DAT
4	DPD_TP0	14	GND	24	DPD_TN3	34	DPD_AUXN_DAT
5	DPC_TN0	15	DPC_TP2	25	GND	35	GND
6	DPD_TN0	16	DPD_TP2	26	GND	36	GND
7	GND	17	DPC_TN2	27	DPC_AUX_SEL	37	DPC_DET
8	GND	18	DPD_TN2	28	DPD_AUX_SEL	38	DPD_DET
9	DPC_TP1	19	GND	29	GND	39	DPC_PWR
10	DPD_TP1	20	GND	30	GND	40	DPD_PWR



### J17: MXM\_DP(A/B)

Pin	Function	Pin	Function	Pin	Function	Pin	Function
1	GND	11	DPA_TN1	21	DPA_TP3	31	DPA_AUXP_CLK
2	GND	12	DPB_TN1	22	DPB_TP3	32	DPB_AUXP_CLK
3	DPA_TP0	13	GND	23	DPA_TN3	33	DPA_AUXN_DAT
4	DPB_TP0	14	GND	24	DPB_TN3	34	DPB_AUXN_DAT
5	DPA_TN0	15	DPA_TP2	25	GND	35	GND
6	DPB_TN0	16	DPB_TP2	26	GND	36	GND
7	GND	17	DPA_TN2	27	DPA_AUX_SEL	37	DPA_DET
8	GND	18	DPB_TN2	28	DPB_AUX_SEL	38	DPB_DET
9	DPA_TP1	19	GND	29	GND	39	DPA_PWR
10	DPB_TP1	20	GND	30	GND	40	DPB_PWR



### J10: LVDS

Pin	Function	Pin	Function	Pin	Function
1	LVDSB_CLK+	11	LVDSB2+	21	LVDSB0-
2	GND	12	LVDSA_CLK-	22	LVDSA1-
3	LVDSB_CLK	13	LVDSB2-	23	GND
4	LVDSA3+	14	GND	24	LVDSA0+
5	GND	15	LVDSB1+	25	LVDS_SCLK
6	LVDSA3-	16	LVDSA2+	26	LVDSA0-
7	LVDSB3+	17	LVDSB1-	27	LVDS_SDATA
8	GND	18	LVDSA2-	28	GND
9	LVDSB3-	19	LVDSB0+	29	LVDS_VCC
10	LVDSA_CLK+	20	LVDSA1+	30	LVDS_VCC



### SIM\_CARD1

Pin	Function	Pin	Function
1	UIM_PWR	4	GND
2	UIM_RESET	5	UIM_VPP
3	UIM_CLK_R	6	UIM_DATA





### JUSB2: USB2.0 (USB4/USB5)

Pin	Function	Pin	Function
1	5V_USB4	6	5V_USB5
2	USB2_DN4	7	USB2_DN5
3	USB2_DP4	8	USB2_DP5
4	GND	9	GND
5	GND	10	GND



### J8: VGA

Pin	Function
1	VGA_VS
2	VGA_SCL
3	VGA_HS
4	VGA_SDA
5	GND
6	VGA_VCC
7	VGA_R
8	VGA_B
9	VGA_G

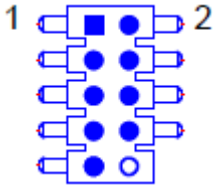

### J9: DIO

Pin	Function
1	GPIO
2	GPO0
3	GPI1
4	GPO1
5	GPI2
6	GPO2
7	GPI3
8	GPO3
9	5V
10	GND

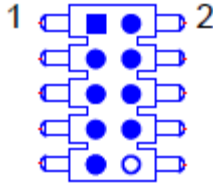

### J11: LVDS Backlight

Pin	Function
1	BKL_VOL
2	LBKLT_CTRL
3	GND
4	GND
5	Backlight_EN



**JP23: LVDS Backlight Power select**

Pin	Function
(1-2) Closed	5V
(2-3) Closed	12V

**JP24: LVDS Signal Power select**

Pin	Function
(1-2) Closed	5V
(2-3) Closed	3.3V

**No31: LPC/COM2/3/4**

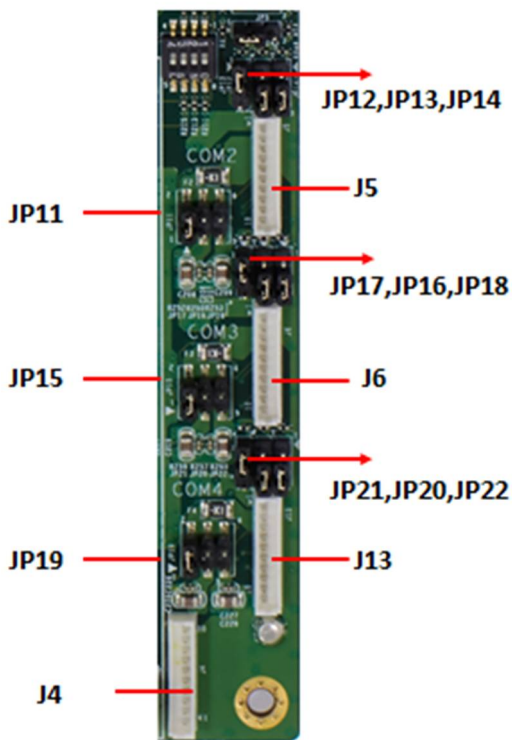

**J4: LPC**

Pin	Function
1	GND
2	GND
3	3V3
4	LPC_AD0
5	LPC_AD1
6	LPC_AD2
7	LPC_AD3
8	LPC_FRAME-
9	LPC_RST#
10	CLK_DBG

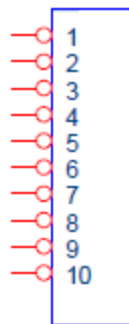

**J5: COM2 / J6: COM3 / J13: COM4**

Pin	RS232	RS422	RS485
1	5V	NC	NC
2	GND	GND	GND
3	COM_P9	NC	NC
4	DTR-	RX-	Data-
5	CTS-	NC	NC
6	TXD	RX+	Data+
7	RTS-	NC	NC
8	RXD	TX+	NC
9	DSR-	NC	NC
10	DCD-	TX-	NC

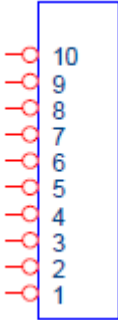

**JP12, JP13: COM2 Mode select**

JP8	JP9	Mode
(2-3)	(2-3)	RS232
(1-2)	(2-3)	RS485 Half Duplex
(1-2)	(1-2)	RS485/422 Full Duplex

**JP14: Enable COM2 RS-485/422 Receiver Termination**

Pin	Function
(1-2) Closed	High
(2-3) Closed	Low

**JP11: COM2 Pin9 select**

Pin	Function
(1-2) Closed	RI
(3-4) Closed	+5V
(5-6) Closed	+12V

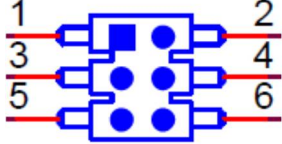

**JP16, JP17: COM3 Mode select**

JP8	JP9	Mode
(2-3)	(2-3)	RS232
(1-2)	(2-3)	RS485 Half Duplex
(1-2)	(1-2)	RS485/422 Full Duplex

**JP18: Enable COM3 RS-485/422 Receiver Termination**

Pin	Function
(1-2) Closed	High
(2-3) Closed	Low

**JP15: COM3 Pin9 select**

Pin	Function
(1-2) Closed	RI
(3-4) Closed	+5V
(5-6) Closed	+12V

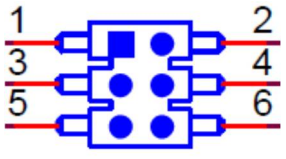

**JP20, JP21: COM4 Mode select**

JP8	JP9	Mode
(2-3)	(2-3)	RS232
(1-2)	(2-3)	RS485 Half Duplex
(1-2)	(1-2)	RS485/422 Full Duplex

**JP22: Enable COM4 RS-485/422 Receiver Termination**

Pin	Function
(1-2) Closed	High
(2-3) Closed	Low

**JP19: COM4 Pin9 select**

Pin	Function
(1-2) Closed	RI
(3-4) Closed	+5V
(5-6) Closed	+12V

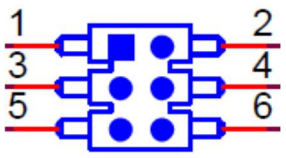

**CN26, CN27: SATA**

Pin	Function
1	GND
2	SATA_TP
3	SATA_TN
4	GND
5	SATA_RN
6	SATA_RP
7	GND



**J2, J3: SATA Power**

Pin	Definition
1	12V
2	GND
3	GND
4	5V



### CN14: M\_PCIE1 (mini PCIe Slot)

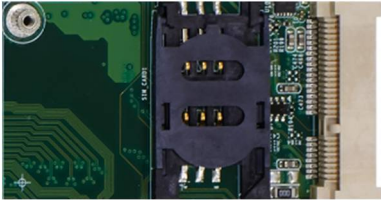

### CN3: M.2 (2280 M key, SATA only)

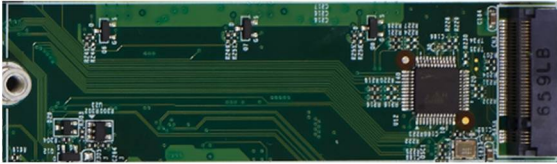

### CN36: StackPC1

