



AV600-TH-A10H



Military IP66 Mission Computer



- MIL-STD 810 Thermal, shock, vibration, Humidity / EMI / EMC
- IP66 Chassis with D38999 connectors
- Intel® 11th Gen. Tiger Lake (H) Xeon® W-11865MLE processor
- Up to 96 GB DDR4 SO-DIMM, non-ECC and ECC
- NVIDIA RTX™ A1000, 2048 CUDA® cores, 4GB GDDR6 memory
- MIL-STD-461 18V~36V DC-Input (Options for MIL-704/1275)
- Extreme Temperature : -40 ~+55 Degree
- Optional with External GPU Turbo Kit
- Dimensions : 250(W) x 325 (L) x 100 (H) mm

Special Request :

- Frame Grabber : 4xCH HD-SDI
- Discrete IO : 4xDI 4Xdo
- Dual Redundant MIL-STD-1553 connections
- Dual ARINC 429 input connections



LAND



SEA



AIR



Specifications

System

CPU	Intel Xeon W-11865MLE (8 Cores/16 Threads, 24M Cache, up to 4.50 GHz), 25W
Memory type	4 x 260 Pin DDR4 2400MHz SO-DIMM (up to 128GB, XEON®SKU support ECC)
CHIPSET	CM246
GPU (optional)	NVIDIA RTX™ A1000 embedded graphics - Standard MXM 3.1 Type A (82 x 70 mm) - 2048 CUDA® cores, 16 RT Cores, and 64 Tensor Cores - 6.66TFLOPS peak FP32 performance - 4GB GDDR6 memory, 128-bit
On Board Storage	mSATA 512GB
Expansion Slot	1 x M.2(M-key,Type: 2280 , SATA/PCIe 3.0 x 4 NVMe) 2 x Mini PCIe Full size (USB / PCIe and 1 x micro SIM Card) 1 x PCIe/104, 1 x FPE
TPM	TPM 2.0 (SLB9665)
VIDEO INPUT (optional)	4 Channel capture module for 4 x SMA male connectors (optional)

Storage

SATA	2 x 2.5" SSD
M.2	1 x M.2(M-key,Type: 2280 , SATA/PCIe 3.0 x 4 NVMe)

Ethernet

Ethernet (Internal)	2 x 10/100/1000 Ethernet Ports
------------------------	--------------------------------

Front I/O

DC-in	1 x DC-in , with D38999 connector
X1	1 x DVI , with D38999 connector
X2	1 x DVI , with D38999 connector
X3	2 x GLAN + 3 x USB 2.0, with D38999 connector
X4	4 x RS232/422/485 + 4 BIT DIO, with D38999 connector
LED	1 x SSD/HDD LED indicator
switch	1 x IP65 power button , with LED indicator

Power

Power input	MIL-STD -461 18V~36V DC-Input
-------------	-------------------------------

Operating System

OS	Windows® 10 64-bit / Linux (support by request)
----	---

Physical

Dimension	246(W) x 325 (L) x 100 (H)mm
Weight	(TBD)
Chassis	SECC
Heatsink	Heatsink Aluminum Alloy, Corrosion Resistant

Environmental

Green Product	RoHS, WEEE compliance
Operating Temp.	-40°C to +60°C
Storage Temp.	-40°C to +85°C
Relative Humidity	5% to 95%, non-condensing

MIL-STD-810 Specifications (Operating)

Method 502.5 Procedure 2	Low Temperature	-20°C, 4 hours, ±3°C
Method 501.5 Procedure 2	High Temperature	+55°C, 4 hours, ±3°C
Method 507.5	Humidity	85%-95% RH without condensation, 24 hours/ cycle, conduct 10 cycles.
Method 514.6	Vibration	5-500Hz, Vertical 2.20Grms, 40mins x 3axis.
Method 516.6	Shock	20 Grms, 11ms, 3 axes.

MIL-STD-810 Specifications (None-Operating)

Method 502.5 Procedure 1	Low Temperature Storage	-33°C, 4 hours, change rate: ≤ 20°C/ Hour -15°C, 72hours (By request)
Method 501.5 Procedure 1	High Temperature Storage	+71°C, 4 hours, change rate: ≤ 20°C/ Hour. +63°C, 240 hours (By request)
Method 514.6	Vibration	5-500Hz, Vertical 2.20Grms, 40mins x 3axis.

Method 516.6	Shock	20 Grms, 11ms, 3 axes.
--------------	-------	------------------------

MIL-STD-461

Conducted Emissions	CE102 basic curve	10kHz – 30MHz
Power Leads		
Radiated Susceptibility	RS103	1.5 MHz – 3GHz, 50 V/m equal for all frequencies 2MHz – 80MHz, 50 V/m equal for all frequencies
Electric Field		80MHz – 3GHz, 50 V/m equal for all frequencies 3GHz – 5GHz, 50 V/m equal for all frequencies
Electrostatic Discharge	EN 61000-4-2	Air DISCHARGE: 8 Kv, Contact discharge : 6kV
Electromagnetic compatibility	EN61000-4-4	Signal and DC Net: 1 kV
Electromagnetic compatibility	EN61000-4-5	Lead vs. ground potential 1Kv, ignal und DC Net: 1 kV
Radio disturbance	EN55022	Class A
Electromagnetic compatibility	EN61000-4-3	10V/m
Electromagnetic compatibility	EN 61000-4-5	Lead vs. ground potential 1Kv, ignal und DC Net: 0.5 kV

MIL-STD-1275 (Options)

Steady State	20V-33V
Surge Low	18V/500ms
Surge High	100V/500ms

Block Diagram

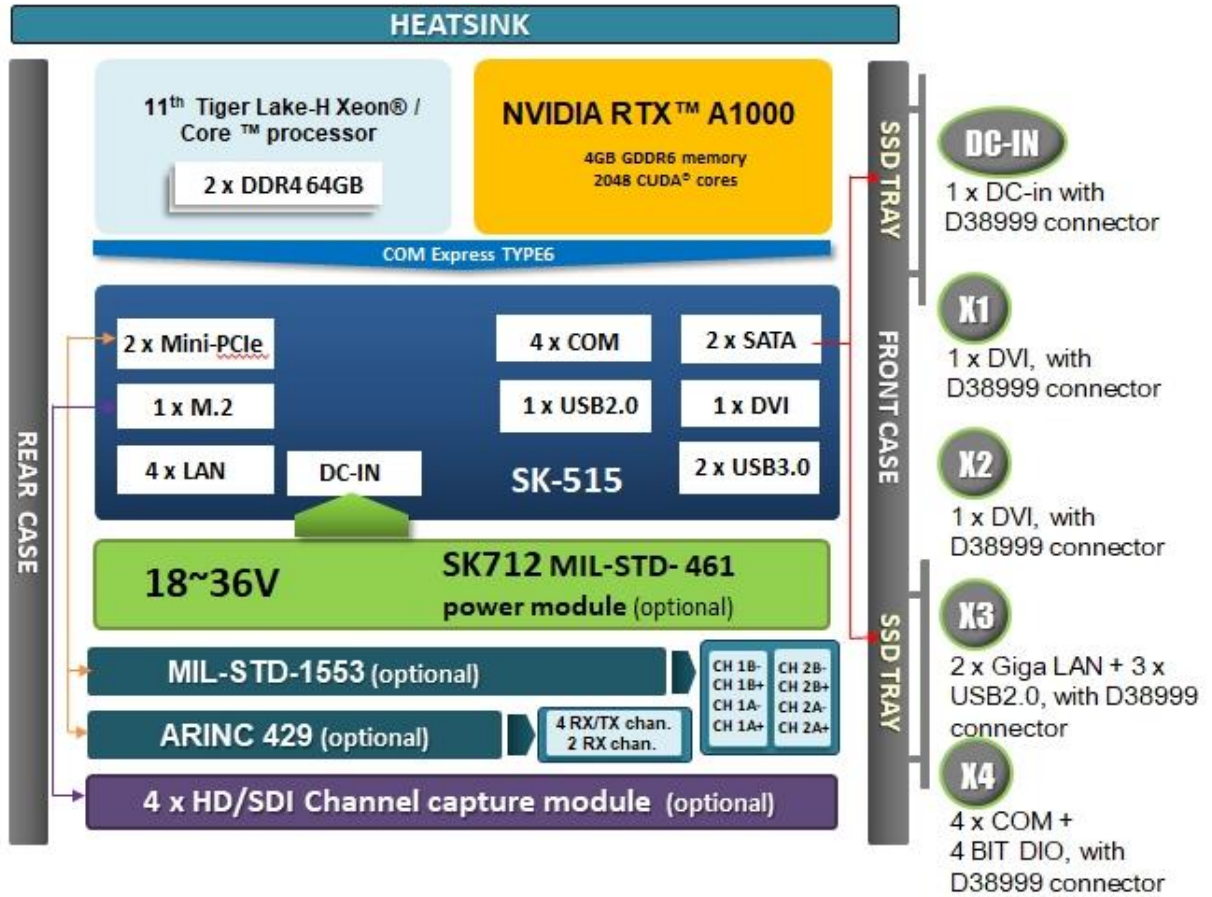

Appearance

