



LAND



SEA



AIR

# THOR200-X11EHG2

2U Half Military High Performance Computer



## Features

- MIL-STD810 Thermal, shock, vibration, Humidity / EMI / EMC conditions
- Intel® Tiger Lake-H i7-11850HE Processors (up to 8 cores)
- NVidia RTX A2000 (3328 CUDA)
- Up to 64GB DDR4 SO-DIMM
- 2 x Swappable SSD Tray
- Compliant with MIL-STD-810
- 18V~36V MIL-STD-461/MIL-STD-1275
- IP65 Chassis with D389999
- Extreme Temperature : -40 ~+60 degree



# Specifications

## System

Processor	Intel® Core™ i7-11850HE, 2.6(4.7) GHz, 24MB, 45W, 8C/16T
Memory type	Up to 64GB DDR4 SO-DIMM
Chipset	Intel® QM580E
Graphic	Embedded NVIDIA® RTX™ A2000 - Ampere Architecture - 2560 CUDA® cores, 20 RT Cores, and 80 Tensor Cores - 4GB GDDR6 memory, 128-bit
TPM	Chipset: Infineon, Type: TPM 2.0
BIOS	AMI UEFI BIOS
USB	4 x USB 3.0, 2 x USB 2.0
Ethernet	2 x 10/100/1000 Ethernet Ports (1 X LAN form mini-PCIE LAN module card)
Power Type	18V ~ 36V DC IN MIL-STD 461 EMI DC Module
Storage	2 x2.5" SATA SSD (2x Swappable SSD Tray)
COM Port	2 x RS232/422/485 (function select by jumper)
Operating Temperature	-40°C to +60°C
Dimension	230mm(W) x 350mm(L)x88mm(H) (TBD)

## FRONT I/O

X1	3 x USB 2.0 with D38999 connector
X2	2 x LAN with D38999 connector
X3	1 x USB 3.0 with D38999 connector
X4	2 x RS232 with D38999 connector
X5	1 x VGA , 1 x DVI with D38999 connector
DC-in	1 x DC-IN with D38999 connector

## Environmental

Method 500.5, Procedures I and II (Altitude, Operation):  
12,192M, (40,000 ft) for the initial cabin altitude (18.8Kpa or 2.73 Psia)  
Method 500.5, Procedures III and IV (Altitude, Non-Operation):  
15,240, (50,000 ft) for the initial cabin altitude (14.9Kpa or 2.16 Psia)

MIL-STD-810 Test	<p>Method 501.5, Procedure I (Storage/High Temperature)</p> <p>Method 501.5, Procedure II (Operation/High Temperature)</p> <p>Method 502.5, Procedure I (Storage/Low Temperature)</p> <p>Method 502.5, Procedure II (Operation/Low Temperature)</p> <p>Method 503.5, Procedure I (Temperature shock)</p> <p>Method 507.5, Procedure II (Temperature &amp; Humidity)</p> <p>Method 509.7 Salt Spray (50±5)g/L</p> <p>Method 514.6, Vibration Category 24/Non-Operating (Category 20 &amp; 24,Vibration)</p> <p>Method 514.6, Vibration Category 20/Operating (Category 20 &amp; 24,Vibration)</p> <p>Method 516.6, Shock-Procedure V Non-Operating (Mechanical Shock)</p> <p>Method 516.6, Shock-Procedure I Operating (Mechanical Shock)</p>
Reliability	<p>No Moving Parts; Passive Cooling.</p> <p>Designed &amp; Manufactured using ISO 9001 Certified Quality Program.</p>
MIL-STD-461	<p>CE102 basic curve, 10kHz - 30 MHz</p> <p>RE102-4, (1.5 MHz) -30 MHz - 5 GHz</p> <p>RS103, 200 MHz - 3.2 GHz, 50 V/m equal for all frequencies</p> <p>EN 61000-4-2: Air discharge: 8 kV, Contact discharge: 6kV</p> <p>EN 61000-4-3: 10V/m</p> <p>EN 61000-4-4: Signal and DC-Net: 1 kV</p> <p>EN 61000-4-5: Leads vs. ground potential 1kV, Signal und DC-Net: 0.5 kV</p> <p>CE and FCC</p>
MIL-STD-1275	<p>Steady State – 20V~33V,</p> <p>Surge Low – 18V/500ms,</p> <p>Surge High – 100V/500ms</p> <p>Emitted spikes</p> <p>Injected Voltage surges</p> <p>Emitted voltage surges</p> <p>Voltage ripple (2V)</p> <p>Voltage spikes</p> <p>Starting Operation</p> <p>Reverse polarity</p>
Operating Temp	-40 to +60°C (ambient with air flow)
Storage Temp.	-40 to +85°C
Relative Humidity	5% to 95%, non-condensing.

# Block Diagram

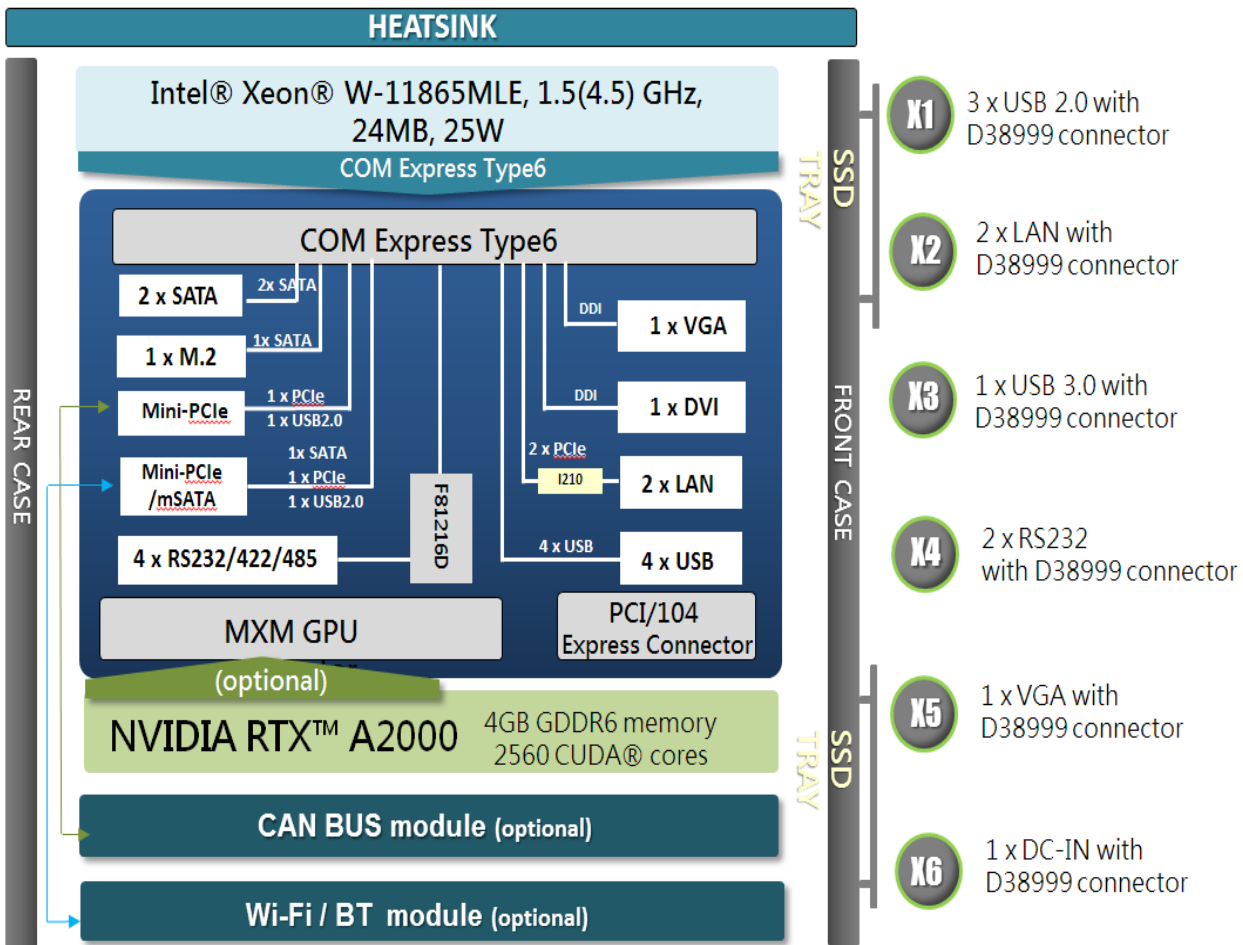

# Ordering Information

	THOR200-X11-EHG2	THOR200-X11-EH	THOR200-X11-HME 2	THOR200-X11-HML2	THOR200-D15EG
<b>CPU</b>	I7-11850HE(8C)	W-11865MRE	W-11862MRE	W-11865MLE(8C)	Xeon D-1577(16C)
<b>GPU</b>	NVIDIA RTX A2000	NVIDIA RTX A2000	NVIDIA RTX A2000	NVIDIA RTX A2000	NVIDIA RTX A2000
<b>RAM</b>	DDR4 Up to 64GB	DDR4 Up to 64GB	DDR4 Up to 64GB	DDR4 Up to 64GB	DDR4 Up to 128GB
<b>RAID</b>	RAID 0/1	RAID 0/1	RAID 0/1	RAID 0/1	RAID 0/1
<b>Storage</b>	2x2.5" SATA Drive	2x2.5" SATA Drive	2x2.5" SATA Drive	2x2.5" SATA Drive	2x2.5" SATA Drive
<b>PSU</b>	18V~36V MIL-461	18V~36V MIL-461	18V~36V MIL-461	18V~36V MIL-461	18V~36V MIL-461
<b>I/O</b>	1 x USB3.0	1 x USB3.0	1 x USB3.0	1 x USB3.0	1 x USB3.0
	3 x USB2.0; 2 x RS232	3 x USB2.0; 2 x RS232	3 x USB2.0; 2 x RS232	3 x USB2.0; 2 x RS232	3 x USB2.0; 2 x RS232
	2 x LAN	2 x LAN	2 x LAN	2 x LAN	2 x LAN
	1 x DVI	1 x DVI	1 x DVI	1 x DVI	1 x DVI
	1 x VGA	1 x VGA	1 x VGA	1 x VGA	1 x VGA
	1 x DC	1 x DC	1 x DC	1 x DC	1 x DC

## Appearance

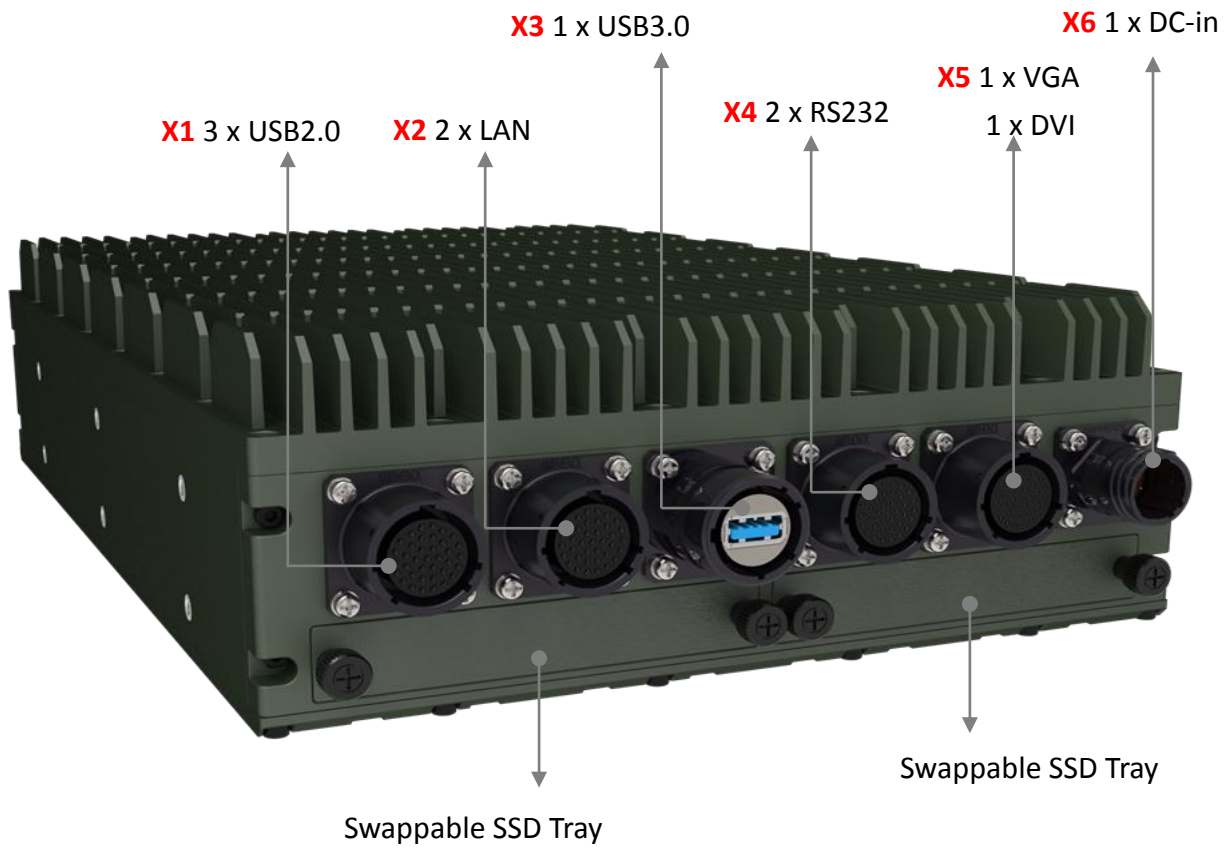

# Dimension

