



LAND



SEA



AIR

AV600X-CX

4CH 3G-SDI Military Frame Grabber-GPU Based System



- 4 Video Input by 4x 3G-SDI or 4x Composite (PAL)
- Support up to 2 video output channels.
- Support Output channel a Bird's-Eye-View
- 360 Stitching View from 4 Digital Video Channel
- Picture-In-Picture (PIP) up to 2 videos on top screen
- IP65 Sealed with External Cooling Blade
- MIL-STD-810G Thermal, Shock, Vibration, Humidity
- Power :18V~36V EMI Filter DC Input



INDEX

1. INTRODUCTION

2. MAIN FEATURE

3. EXPANSION FEATURE

4. SYSTEM SPEC.

5. System Diagram

6. SYSTEM I/O

7. ORDERING INFORMATION



1. INTRODUCTION

Artificial intelligence is quickly becoming one of the most crucial elements of business success. Today, deploying powerful computing platforms to accelerate and scale AI-based products and services while adapting them to harsh environments has become vital in many successful military applications. 7Starlake is innovating to address the emerging high-throughput inference market driven by IoTedge devices which are generating huge amounts of data. The combination of FPGA and NVIDIA QUADRO A2000 (MXM) is a powerful solution for demanding and latency-sensitive workloads.

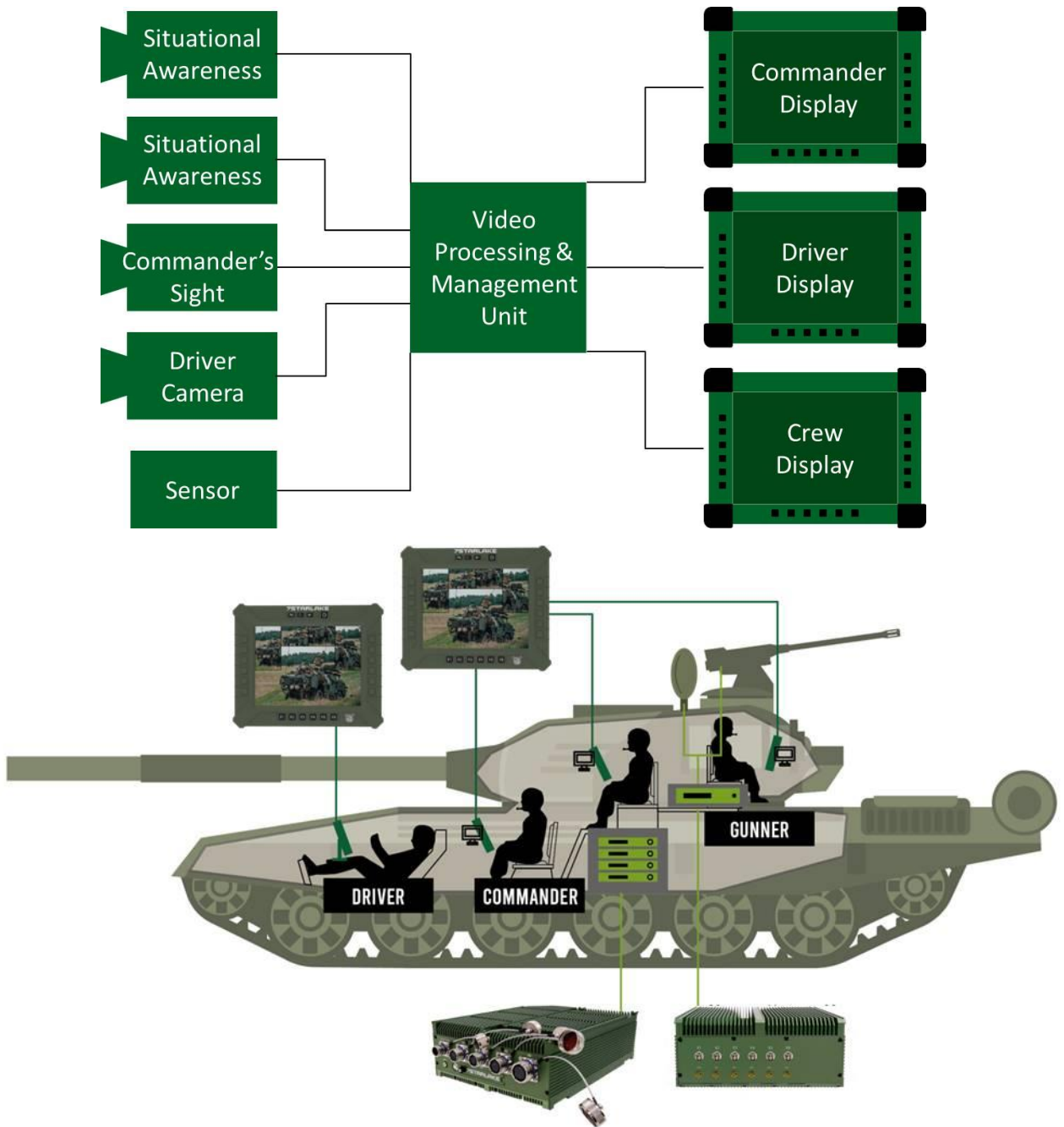

2. MAIN FEATURE

- Connection to Video Input channels, including 4 CH 3G-SDI video channels or 4 composite (PAL) Channels.
- Generate 2 video output channels (Option).
- Keep Low Latency between input video channels and generated output video channels.
- Generated Output channel a Bird's-Eye-View created from 4 CH 3G- SDI input channels.
- Each output channel can be selected into one main channel
- Up to 2 videos inserted on top screen - Picture-In-Picture (PIP).

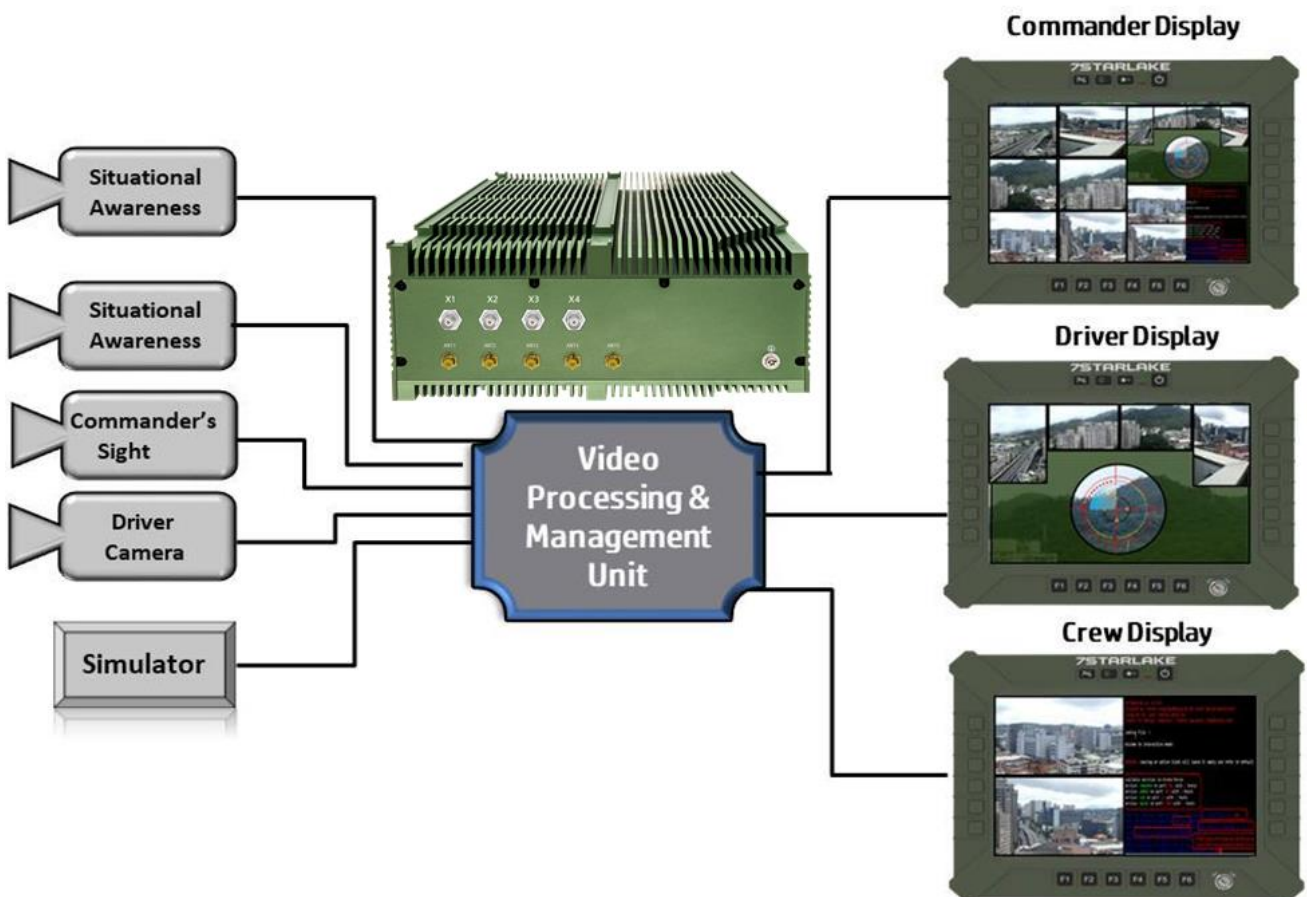

3. EXPANSION FEATURE



Commander Display



← Bird's-Eye-View

← Picture in Picture

Driver Display



← Bird's-Eye-View

Crew Display



← Picture in Picture

4. SYSTEM SPEC

System

CPU	Intel® Xeon® E-2276ME, 6 core, 12 thread, 12MB Cache, 2.8GHz Max Turbo up to 4.5GHz., up to 45W TDP
Memory type	128GB SO-DIMM DDR4-2400 MHz, in 4 DIMM Slot
Chipset	CM246
GPU	Intel® Arc A370M 4G GDDR6 64bit, PCIe Gen3.0 x16 (Option) NVidia® RTX A2000,4G/8G 2560 CUDA Cores,PCIe Gen3.0 x16
Ethernet Controller	Intel® I210 & I219LM GbE LAN(10/100/1000 Mbps supported)
LAN	2 x 1GBase-T(option)
Storage	2 x 2.5" SATA SSD hot-swap
Power Type	18V~36V EMI DC Input
Dimension	250 x350x 100mm (W x Lx H)

Front I/O

COM	2 x RS232/485
USB3.0	1
USB2.0	2
LAN	2 x GbE(option)
Power	1 x DC-IN 18V~36V
LED	1 x SSD LED
PW Button	Power Switch with LED indicator
SSD	2 x SSD swap tray

Rear I/O

SDI Input	4 / 2(option)
SDI Output	2(option)

Environmental

MIL-STD-810 Test	Method 500.5, Procedures I and II (Altitude, Operation): 12,192M, (40,000 ft) for the initial cabin altitude (18.8Kpa or 2.73 Psia) Method 500.5, Procedures III and IV (Altitude, Non-Operation): 15,240, (50,000 ft) for the initial cabin altitude (14.9Kpa or 2.16 Psia) Method 501.5, Procedure I (Storage/High Temperature) Method 501.5, Procedure II (Operation/High Temperature) Method 502.5, Procedure I (Storage/Low Temperature)
------------------	---

	Method 502.5, Procedure II (Operation/Low Temperature) Method 503.5, Procedure I (Temperature shock) Method 507.5, Procedure II (Temperature & Humidity) Method 509.7 Salt Spray (50±5)g/L Method 514.6, Vibration Category 24/Non-Operating (Category 20 & 24,Vibration) Method 514.6, Vibration Category 20/Operating (Category 20 & 24,Vibration) Method 516.6, Shock-Procedure V Non-Operating (Mechanical Shock) Method 516.6, Shock-Procedure I Operating (Mechanical Shock)
Reliability	Conduction Cooling Designed & Manufactured using ISO 9001 Certified Quality Program.
Operating Temp.	0°C to +60°C
Storage Temp.	-40°C to +85°C
Relative Humidity	5% to 95%, non-condensing.
Operating System	
Operating System	Windows 10 64Bit, Linux by option
RoHS	RoHS compliant

5. System Diagram

Solution 1:

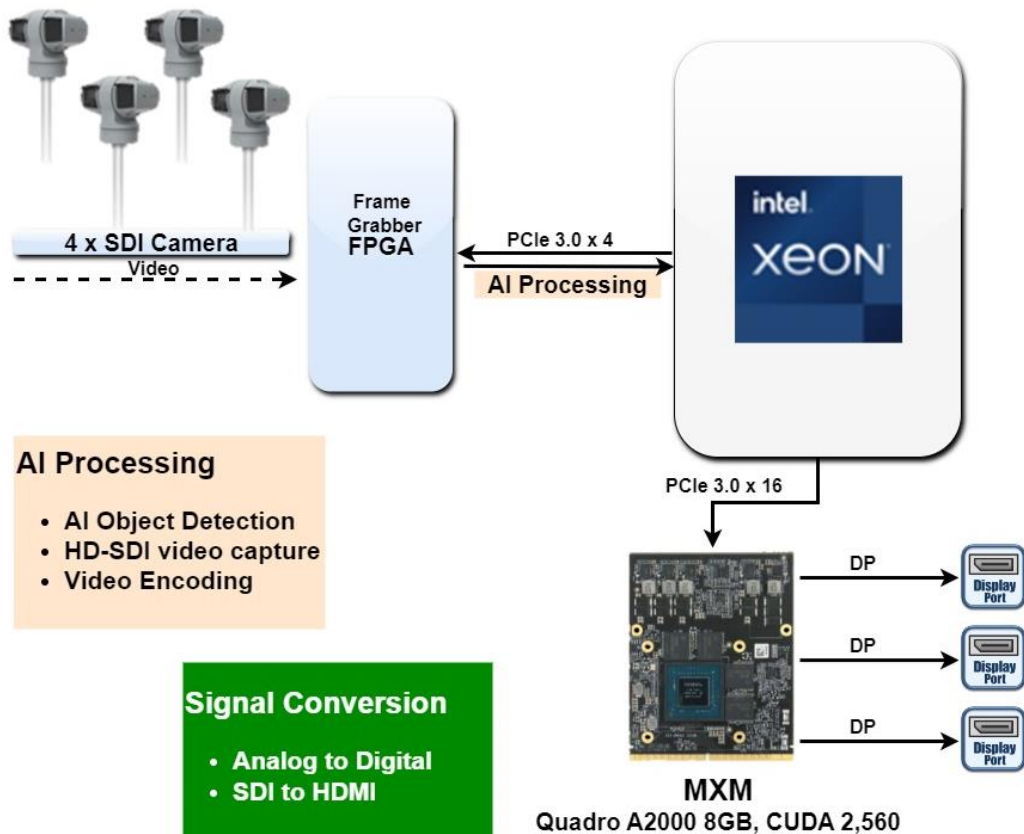

Solution 2:

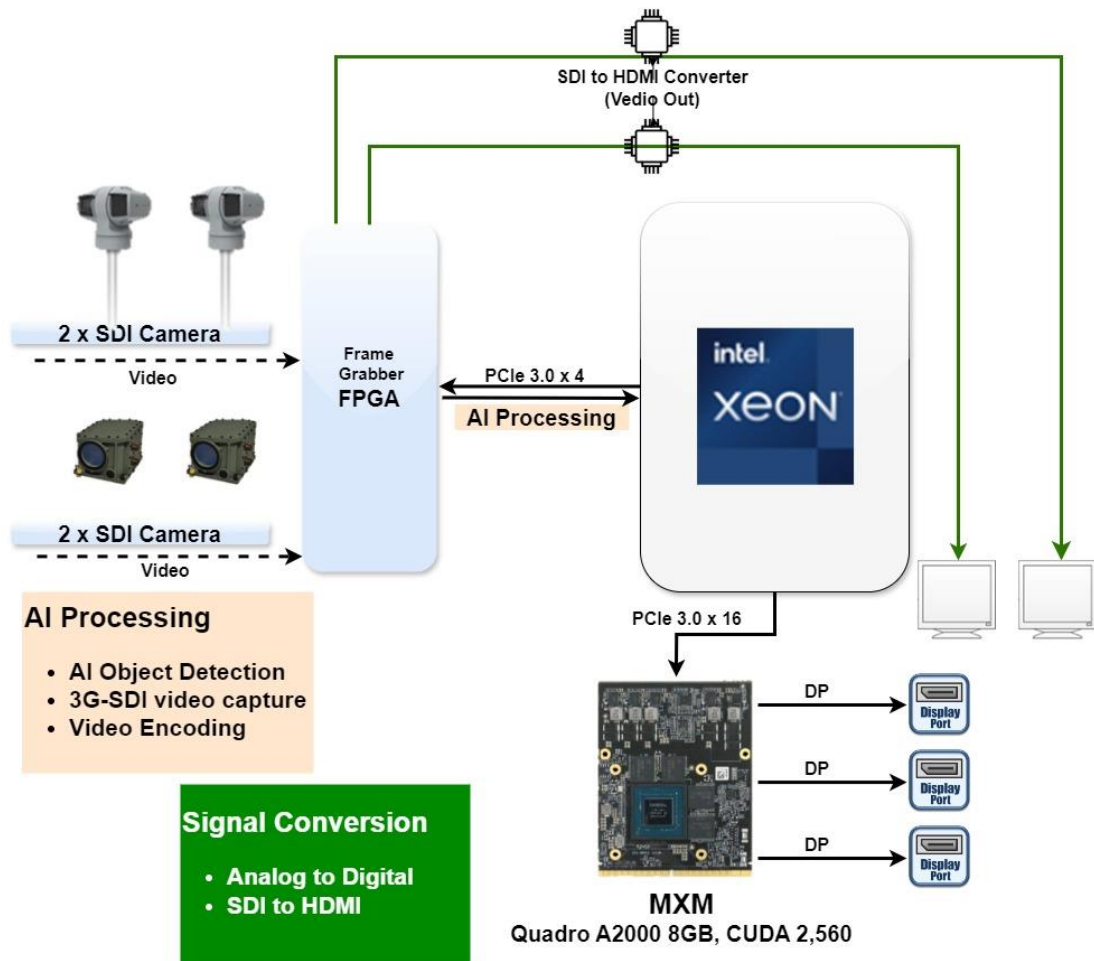

6. System I/O

Front I/O

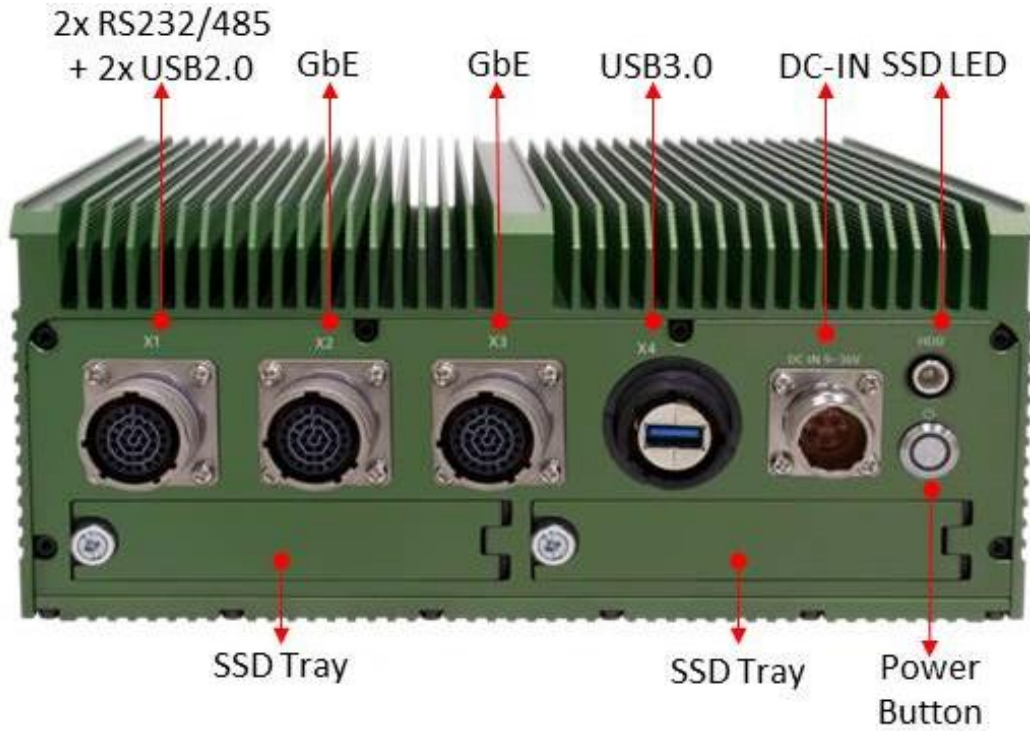

Rear I/O

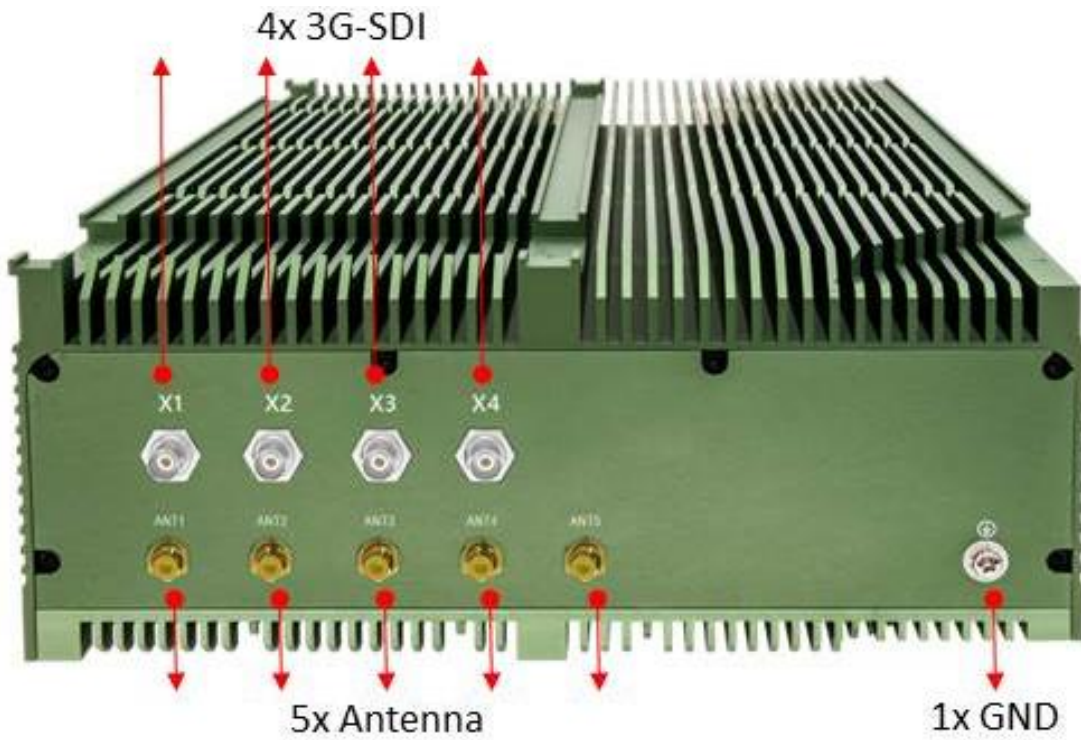

7. Ordering Information

Model	AV600X-CX-A37	AV600X-CX-A24	AV600X-CX-A28
CPU	XEONE-2276ME (6C)	XEONE-2276ME (6C)	XEONE-2276ME (6C)
Memory	128GB DDR4-2400 MHz	128GB DDR4-2400 MHz	128GB DDR4-2400 MHz
GPU	Intel® Arc A370M	NVidia®RTX A2000 4G	NVidia®RTX A2000 8G
Video Input	4 CH 3G-SDI	4 CH 3G-SDI	4 CH 3G-SDI
Video Output	2 x 3G-SDI(option)	2 x 3G-SDI(option)	2 x 3G-SDI(option)
Storage	2 x SATA III SATA SSD	2 x SATA III SATA SSD	2 x SATA III SATA SSD
I/O	2 x RS232/485 2 x USB 2.0 2 x GbE (Option) 1 x USB 3.0 1x DC	2 x RS232/485 2 x USB 2.0 2 x GbE (Option) 1 x USB 3.0 1x DC	2 x RS232/485 2 x USB 2.0 2 x GbE (Option) 1 x USB 3.0 1x DC
Power	18V~36V EMI DC-DC		
Dimension	250 x 350 x 100mm (W x L x H)		