

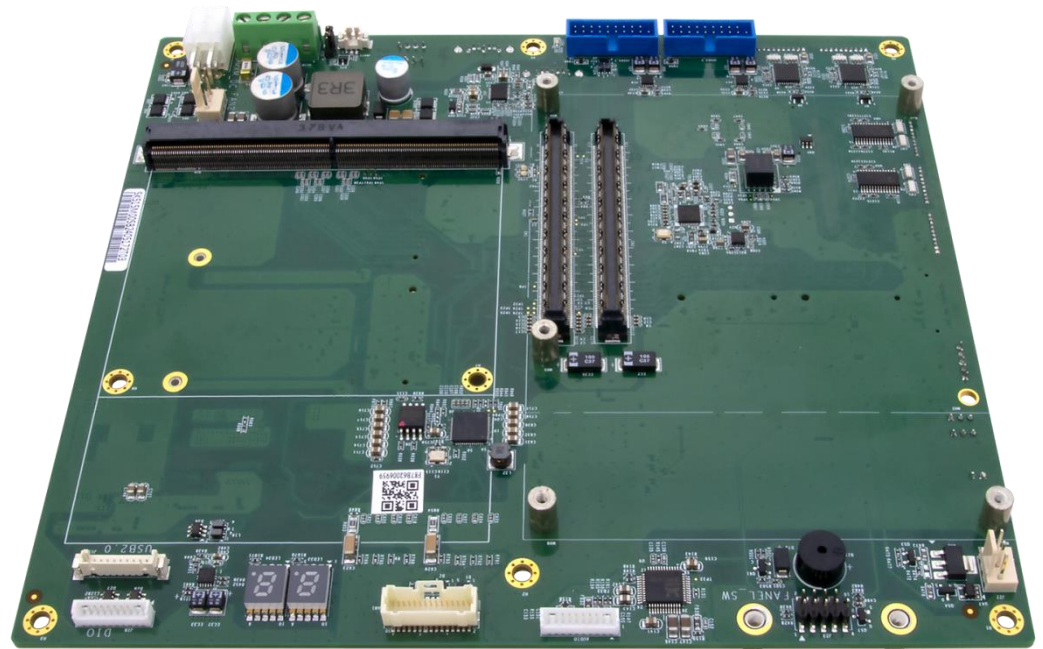

SK515M

COM Express® Type 6 Carrier Board



Safety Information

Electrical safety

- To prevent electrical shock hazard, disconnect the power cable from the electrical outlet before relocating the system.
- When adding or removing devices to or from the system, ensure that the power cables for the devices are unplugged before the signal cables are connected. If possible, disconnect all power cables from the existing system before you add a device.
- Before connecting or removing signal cables from the motherboard, ensure that all power cables are unplugged.
- Seek professional assistance before using an adapter or extension cord. These devices could interrupt the grounding circuit.
- Make sure that your power supply is set to the correct voltage in your area.
- If you are not sure about the voltage of the electrical outlet you are using, contact your local power company.
- If the power supply is broken, do not try to fix it by yourself. Contact a qualified service technician or your local distributor.

Operation safety

- Before installing the motherboard and adding devices on it, carefully read all the manuals that came with the package.
- Before using the product, make sure all cables are correctly connected and the power cables are not damaged. If you detect any damage, contact your dealer immediately.
- To avoid short circuits, keep paper clips, screws, and staples away from connectors, slots, sockets and circuitry.
- Avoid dust, humidity, and temperature extremes. Do not place the product in any area where it may become wet.
- Place the product on a stable surface.
- If you encounter any technical problems with the product, contact your local distributor

Statement

- All rights reserved. No part of this publication may be reproduced in any form or by any means, without prior written permission from the publisher.
- All trademarks are the properties of the respective owners.
- All product specifications are subject to change without prior notice

SK515M User's Manual

Revision Date: Jun.18.2024

Revision History

Revision	Date (yyyy/mm/dd)	Changes
Version 1.0	2024/06/18	Initial release
Version 2.0	2024/07/05	Correct JP30, 29, J25, and connector picture w/pin No.

Index

SAFETY INFORMATION	1
REVISION HISTORY	2
1. CHAPTER 1: PRODUCT INTRODUCTION	4
1-1. SPECIFICATIONS	4
1-2. BOARD DIAGRAM	6
1-3. CONNECTOR & PIN HEADER	7
2. CHAPTER 2: JUMPERS AND CONNECTORS LOCATIONS	8
2.1. CONNECTOR & PIN DEFINITIONS	8

SK515M User's Manual

Revision Date: Jun.18.2024

1. CHAPTER 1: PRODUCT INTRODUCTION

1-1. Specifications

System

	Intel® Core™ Ultra 7 Processor 165H, 20-45W, Meteor Lake 14 th Gen, 14+2C, Freq. 0.9/1.4 Max. 5.0 GHz, 24MB cache
COM Express CPU Options (Type 6)	Intel® Core™ Ultra 7 Processor 155H, 20-45W, Meteor Lake 14th Gen, 14+2C, Freq. 0.9/1.4 Max. 4.8 GHz, 24MB cache Intel® Core™ Ultra 5 Processor 125H, 20-45W, Meteor Lake 14th Gen, 12+2C, Freq. 0.7/1.2 Max. 4.5 GHz, 18MB cache Intel® Core™ i7-13800HRE 45W Raptor Lake 13th Gen, 14C , Freq. 2.5 /5.0 GHz, 24MB cache Intel® Core™ i7-13800HE 45W Raptor Lake 13th Gen, 14C , Freq. 2.5 /5.0 GHz, 24MB cache
GPU Module Options	NVIDIA® Ampere RTX A2000, 80W, 8GB GDDR6, 2,560 CUDA Cores NVIDIA® Ampere RTX A4500, 80W/130W, 16GB GDDR6, 5,888 CUDA Cores NVIDIA® Ada Lovelace RTX 3500 Ada, 115W, 12GB GDDR6, 5,120 CUDA Cores NVIDIA® Ada Lovelace RTX 5000 Ada, 115W, 16GB GDDR6, 9,728 CUDA Cores
Compatibility	COM Express® Type 6

Display

Display Port	2x Display Port outputs from GPU
VGA	1x output from COM Express
LVDS	1x Dual channel 18/24bit LVDS
DVI	1x output from COM Express

Expansion

MiniPCIe Expansion	2x Full-size Mini PCIe (with SIM card slot)
M.2 Expansion	2 x 2280 M-key (both PCIe x4 from PEG)
SATA	2x SATAIII

Ethernet

Gigabit Ethernet	2x 10/100/1000mb /2.5G Ethernet Ports(One from CPU module)
------------------	------------------------------------------------------------

I/O

USB	4x USB 3.0 + 2x USB 2.0
COM Port	2x RS232(COM1,2) + 2x RS232/422/485(Com3,4)
Audio	1x Line-out, 1x MIC-IN
SATA Power	2x SATA Power

SK515M User's Manual

Revision Date: Jun.18.2024

SATAIII	2x SATAIII
DI/DO	1x DI/DO (4 in / 4 out)
FAN Power	1x CPU FAN
	1x MXM FAN
Battery	1x Battery Header

Power System

Input Power_SYS	9~36V (4P Terminal Block)
Input Power_MXM	12V (ATX 4P)
Power Consumption	Varies per COM Express/ MXM with different CPU and GPU models
RTC Battery	3V CR2032

Mechanical and Environmental

Dimension	170mm x 190mm
Operation Temperature	-40°C to 85°C
Storage Temperature	-40°C to 85°C
Relative Humidity	10% to 90%, non-condensing

Standard Compliance

Standard Compliance	CE / FCC
---------------------	----------

OS

OS Support	Windows®10 64bit, Linux(Support by request)
------------	---------------------------------------------

*All specifications and photos are subject to change without notice.

1-2. Board Diagram

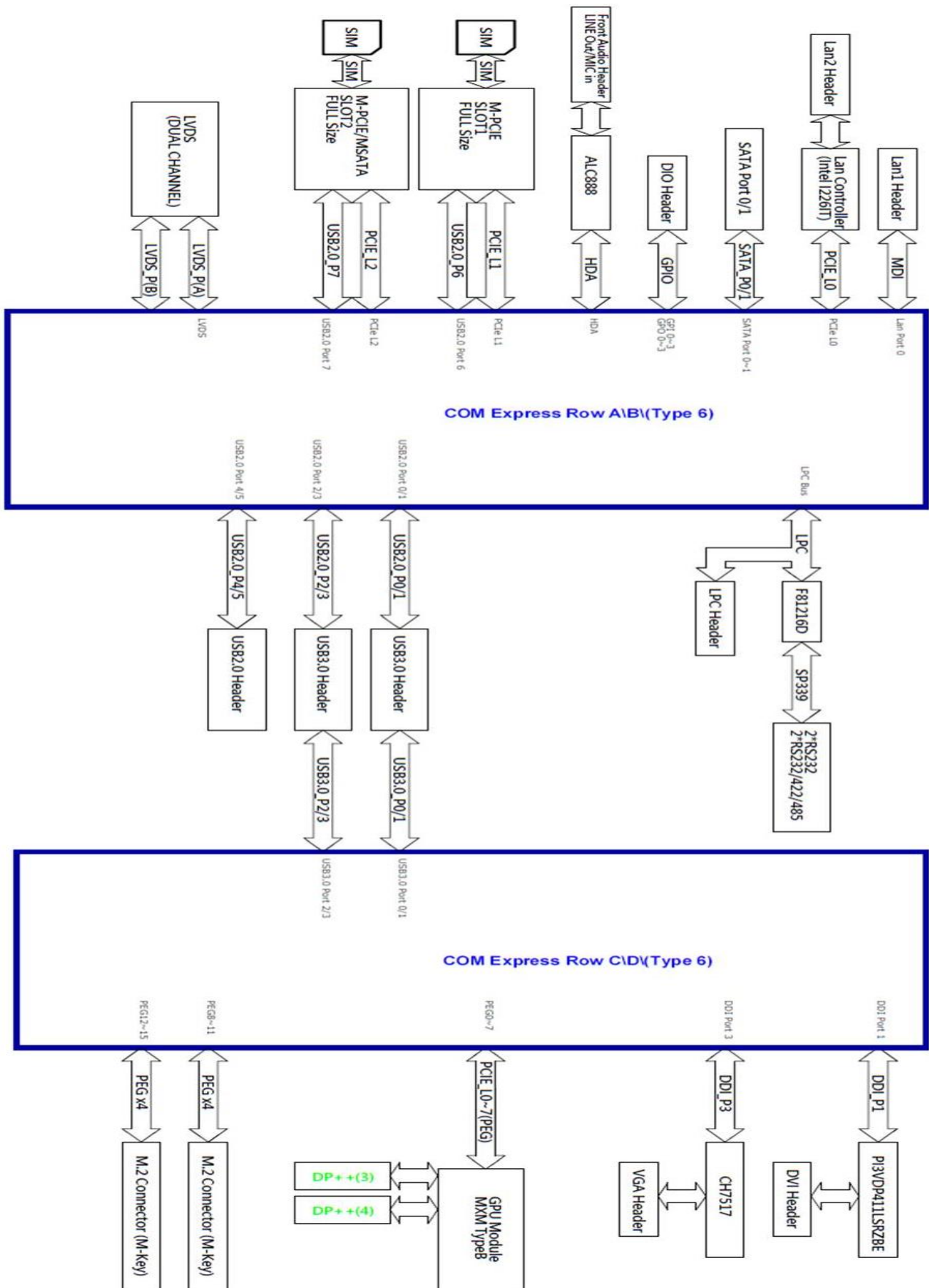

SK515M User's Manual

Revision Date: Jun.18.2024

1-3. Connector & Pin Header

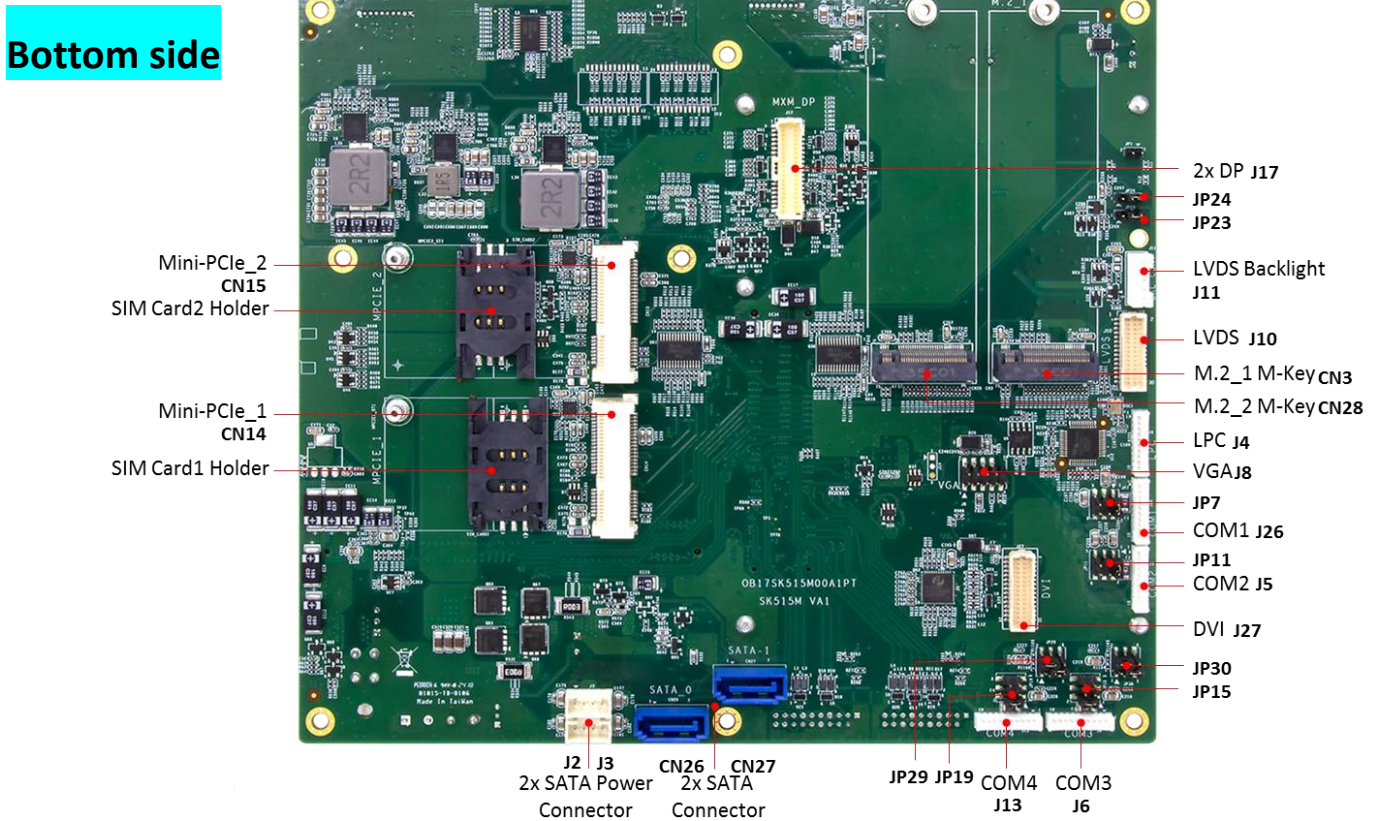
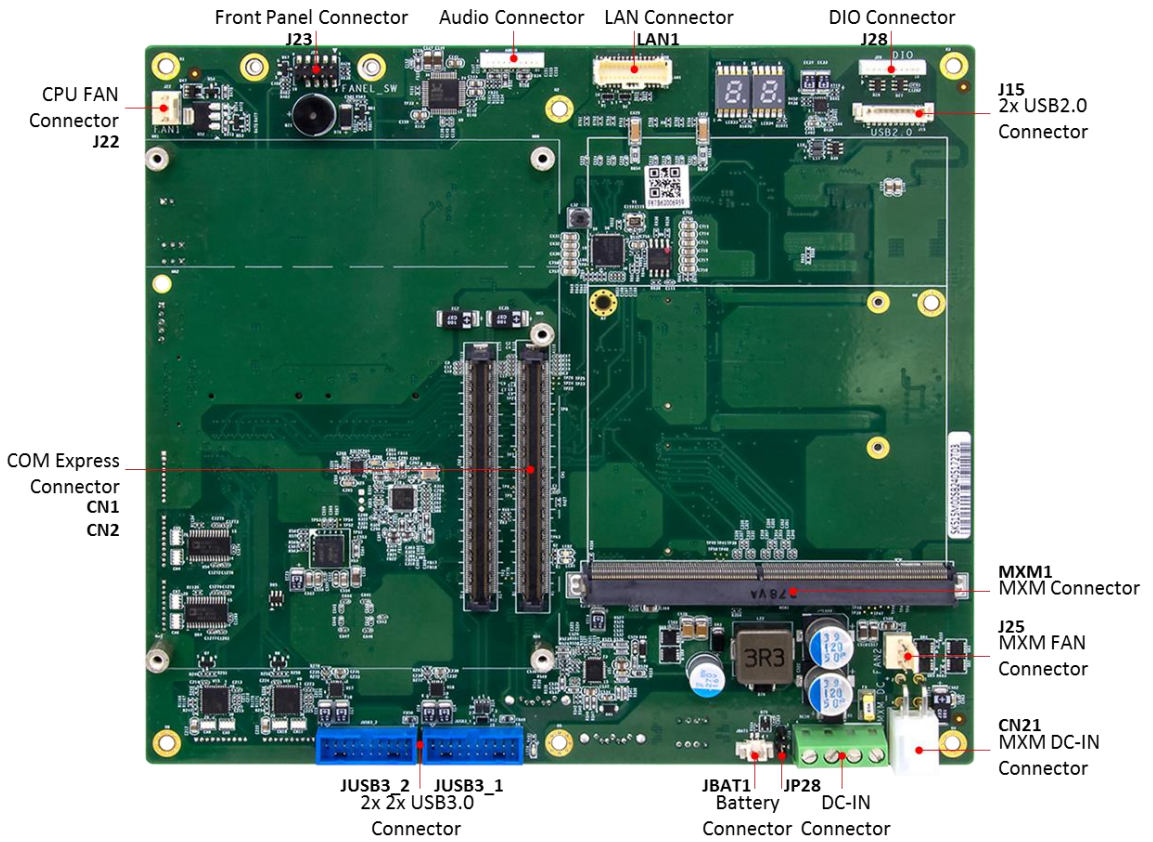

2. CHAPTER 2: JUMPERS AND CONNECTORS LOCATIONS

2.1. Connector & Pin Definitions

J26: COM1 & J5: COM2

Pin	RS232
1	5V
2	GND
3	COM P9
4	DTR-
5	CTS-
6	TXD
7	RTS-
8	RXD
9	DSR-
10	DCD-

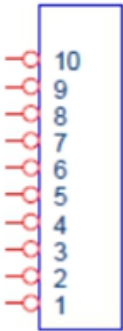

JP7: COM1 Pin select

Pin	Function
(1-2) Closed	RI
(3-4) Closed	+5V
(5-6) Closed	+12V

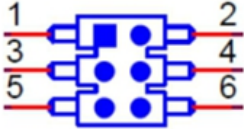

JP11: COM2 Pin select

Pin	Function
(1-2) Closed	RI
(3-4) Closed	+5V
(5-6) Closed	+12V



J6: COM3 / J13: COM4

Pin	RS232	RS422	RS485
1	5V	NC	NC
2	GND	GND	GND
3	COM P9	NC	NC
4	DTR-	RX-	NC
5	CTS-	NC	NC
6	TXD	RX+	NC
7	RTS-	NC	NC
8	RXD	TX+	Data+
9	DSR-	NC	NC
10	DCD-	TX-	Data-

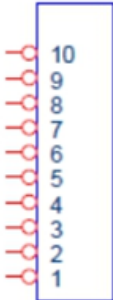

SK515M User's Manual

Revision Date: Jun.18.2024

JP30 : COM3 Mode select

JP30	JP30	Model
(3-5)	(4-6)	Loopback
(3-5)	(2-4)	RS232
(1-3)	(4-6)	RS485 Half Duplex
(1-3)	(2-4)	RS485/422 Full Duplex

JP15: COM3 Pin9 select

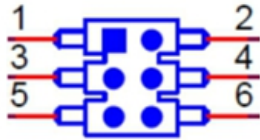
Pin	Function	
(1-2) Closed	RI	
(3-4) Closed	+5V	
(5-6) Closed	+12V	

JP29: COM4 Mode select

JP29	JP29	Model
(3-5)	(4-6)	Loopback
(3-5)	(2-4)	RS232
(1-3)	(4-6)	RS485 Half Duplex
(1-3)	(2-4)	RS485/422 Full Duplex

JP19: COM4 Pin9 select

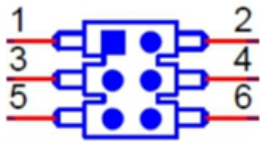
Pin	Function	
(1-2) Closed	RI	
(3-4) Closed	+5V	
(5-6) Closed	+12V	

AUDIO

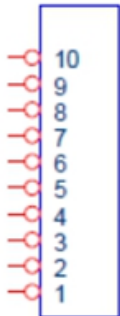
Pi	Function	
1	GND	
2	MIC JD	
3	MIC R	
4	MIC L	
5	FRONT JD	
6	FRONT R	
7	FRONT L	
8	N/C	
9	N/C	
10	N/C	

SK515M User's Manual

Revision Date: Jun.18.2024

JUSB3_1: USB 3.0 Port

Pin	Function	Pin	Function
1	+5V USB0	11	USB2 DP1
2	USB3 RXN0	12	USB2 DN1
3	USB3 RXP0	13	GND
4	GND	14	USB3 TXP1
5	USB3 TXN0	15	USB3 TXN1
6	USB3 TXP0	16	GND
7	GND	17	USB3 RXP1
8	USB2 DN0	18	USB3 RXN1
9	USB2 DPO	19	+5V USB1
10	N/C		

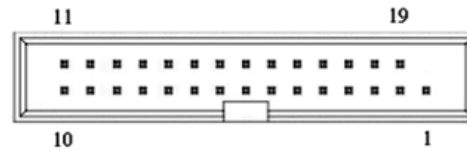

JUSB3_2: USB 3.0 Port

Pin	Function	Pin	Function
1	+5V USB2	11	USB2 DP3
2	USB3 RXN2	12	USB2 DN3
3	USB3 RXP2	13	GND
4	GND	14	USB3 TXP3
5	USB3 TXN2	15	USB3 TXN3
6	USB3 TXP2	16	GND
7	GND	17	USB3 RXP3
8	USB2 DN2	18	USB3 RXN3
9	USB2 DP2	19	+5V USB3
10	N/C		

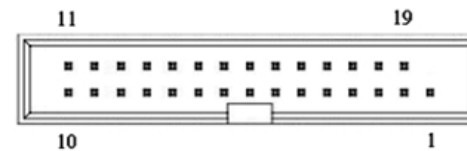

J27: DVI

Pin	Function	Pin	Function	Pin	Function
1	VCC5	11	TMDS DATA1-	21	GND
2	GND	12	N/C	22	N/C
3	GND	13	TMDS DATA1+	23	TMDS CLK-
4	TMDS SCL	14	N/C	24	N/C
5	TMDS DATA2-	15	GND	25	TMDS CLK+
6	TMDS SDA	16	N/C	26	N/C
7	TMDS DATA2+	17	TMDS DATA0-	27	GND
8	GND	18	N/C	28	N/C
9	GND	19	TMDS DATA0+	29	N/C
10	TMDS HPD	20	N/C	30	N/C

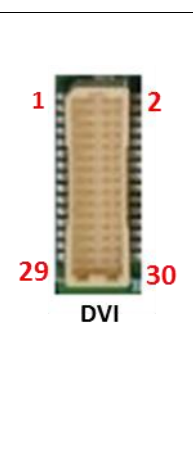

J22: CPU FAN Connector

Pin	Function
1	GND
2	CPUFANOUT
3	+12V

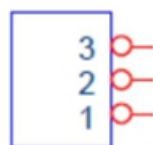

SK515M User's Manual

Revision Date: Jun.18.2024

J25: MXM FAN connector

Pin	Function
1	GND
2	+12V
3	+12V

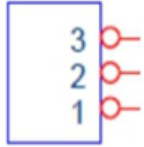

J23: Front Panel

Pin	Function
1	HDLED+
2	PWLED+
3	HDLED-
4	GND
5	GND
6	PWRBTN#
7	RESET
8	GND
9	NC

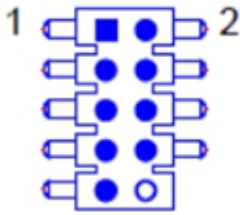

CN1, CN2: COM Express Connector

Support COM Express Basic Size Type 6 Module

CN14: M_PClE 1 (Mini PCIe Slot)



CN15: M_PClE 2 (Mini PCIe Slot)



SIM_CARD1/ SIM_CARD2

Pin	Function	Pin	Function
1	UIM_PWR	4	GND
2	UIM_RESET	5	UIM_VPP
3	UIM_CLK_R	6	UIM_DATA



SK515M User's Manual

Revision Date: Jun.18.2024

J8_VGA

Pin	Function
1	VGA_VS
2	VGA_SCL
3	VGA_HS
4	VGA_SDA
5	GND
6	VGA_VCC
7	VGA_R
8	VGA_B
9	VGA_G

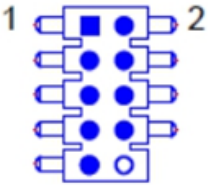

MXM1: MXM Socket



CN21: MXM DC-IN

Pin	Definition
1	12V
2	12V
3	GND
4	GND

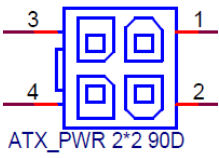

JP28: Clear CMOS

Pin	Function
(1-2) Closed	Normal(default)
(3-4) Closed	Clear CMOS

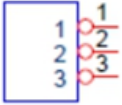

LAN : LAN1

Pin	Function	Pin	Function	Pin	Function
1	MDI2_0PX	12	MDI1_2NX	23	3V3SB
2	MDI1_0PX	13	MDI2_3PX	24	3V3SB
3	MDI2_0NX	14	MDI1_3PX	25	LAN2_LED_100#
4	MDI1_0NX	15	MDI2_3NX	26	GBE_LED_100-
5	MDI2_1PX	16	MDI1_3NX	27	LAN2_LED_1000#
6	MDI1_1PX	17	GND	28	GBE_LED_1000-
7	MDI2_1NX	18	GND	29	GND
8	MDI1_1NX	19	VCC_1V5	30	GND
9	MDI2_2PX	20	GB0_CTREF	31	GND
10	MDI1_2PX	21	LAN2_LED_ACT#	32	GND
11	MDI2_2NX	22	GBE_ACT-		



LAN1

SK515M User's Manual

Revision Date: Jun.18.2024

DC-IN: System DC-IN

Pin	Definition
1	9V~36V
2	9V~36V
3	GND
4	GND

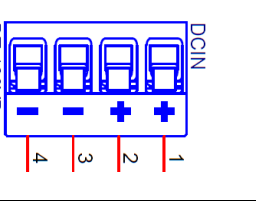

J17: MXM_DP(A/B)

Pin	Function	Pin	Function	Pin	Function	Pin	Function
1	GND	11	DPA TN1	21	DPA_TP3	31	DPA_AUXP_CLK
2	GND	12	DPB TN1	22	DPB_TP3	32	DPB_AUXP_CLK
3	DPA_TP0	13	GND	23	DPA TN3	33	DPA_AUXN_DAT
4	DPB_TP0	14	GND	24	DPB TN3	34	DPB_AUXN_DAT
5	DPA_TN0	15	DPA_TP2	25	GND	35	GND
6	DPB_TN0	16	DPB_TP2	26	GND	36	GND
7	GND	17	DPA_TN2	27	DPA_AUX_SEL	37	DPA_DET
8	GND	18	DPB_TN2	28	DPB_AUX_SEL	38	DPB_DET
9	DPA_TP1	19	GND	29	GND	39	DPA_PWR
10	DPB_TP1	20	GND	30	GND	40	DPB_PWR



J10: LVDS

Pin	Function	Pin	Function	Pin	Function
1	LVDSB_CLK+	11	LVDSB2+	21	LVDSB0-
2	GND	12	LVDSA_CLK-	22	LVDSA1-
3	LVDSB_CLK-	13	LVDSB2-	23	GND
4	LVDSA3+	14	GND	24	LVDSA0+
5	GND	15	LVDSB1+	25	LVDS_SCLK
6	LVDSA3-	16	LVDSA2+	26	LVDSA0-
7	LVDSB3+	17	LVDSB1-	27	LVDS_SDATA
8	GND	18	LVDSA2-	28	GND
9	LVDSB3-	19	LVDSB0+	29	LVDS_VCC
10	LVDSA_CLK+	20	LVDSA1+	30	LVDS_VCC

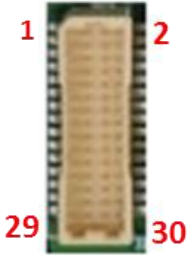

J15: USB2.0 (USB4/USB5)

Pin	Function	Pin	Function
1	5V_USB4	6	5V_USB5
2	USB2_DN4	7	USB2_DN5
3	USB2_DP4	8	USB2_DP5
4	GND	9	GND
5	GND	10	GND



SK515M User's Manual

Revision Date: Jun.18.2024

J28: DIO

Pin	Function
1	GPI0
2	GPI1
3	GPI2
4	GPI3
5	GPO0
6	GPO1
7	GPO2
8	GPO3
9	5V
10	GND



J11: LVDS Backlight

Pin	Function
1	BKL_VOL
2	LBKLT_CTRL
3	GND
4	GND
5	Backlight_EN



JP23: LVDS Backlight Power select

Pin	Function
(1-2) Closed	5V
(2-3) Closed	12V

JP24: LVDS Signal Power select

Pin	Function
(1-2) Closed	5V
(2-3) Closed	3.3V

J4: LPC

Pin	Function
1	GND
2	GND
3	3V3
4	LPC ADO
5	LPC AD1
6	LPC AD2
7	LPC AD3
8	LPC FRAME-
9	LPC RST#



SK515M User's Manual

Revision Date: Jun.18.2024

10	CLK_DBG	
----	---------	--

CN26, CN27: SATA

Pin	Function : CN26	Function : CN27
1	GND	GND
2	SATA TXOP	SATA TX1P
3	SATA TXON	SATA TX1N
4	GND	GND
5	SATA RXON	SATA RX1N
6	SATA RXOP	SATA RX1P
7	GND	GND

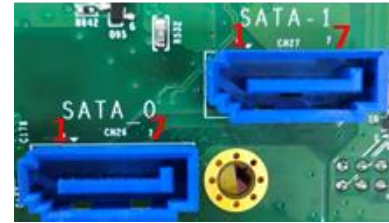

J2, J3: SATA Power

Pin	Definition	
1	12V	
2	GND	
3	GND	
4	5V	

CN3/CN28 : M.2 (2280 M-key, NVMe)

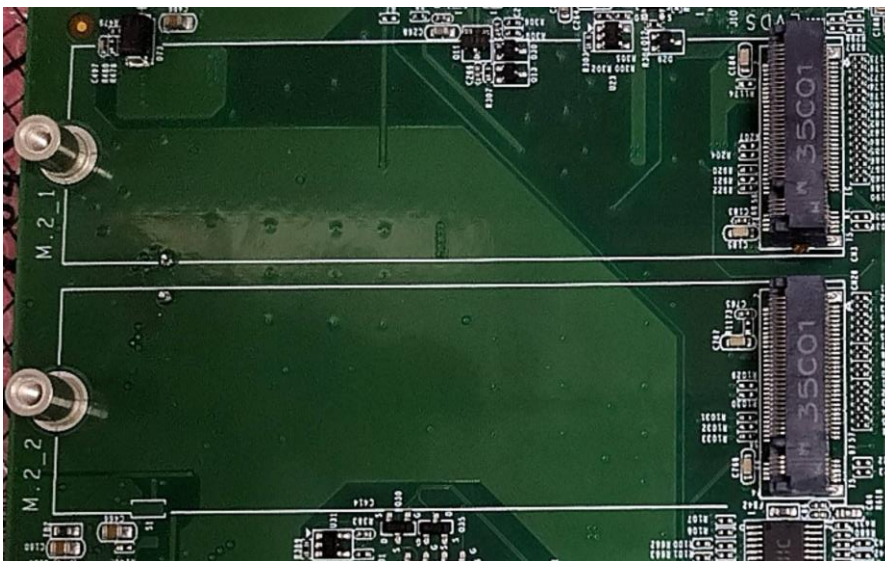

JBAT1: RTC Battery_ CR2032L

