



LAND



SEA



AIR

THOR100S-X130

1 U HALF RACK MILITARY COMPUTER



MIL-STD

461

MIL-STD

810

- Ultra Short Depth 200mm 1U Half Rugged Computer
- Intel® 13th Raptor Lake-P i7-1370PE Processor
- DDR5 up to 32GB
- Anti-Vibration up to 10 Grms, Shock 75G
- IP65 classified
- Support SATAIII RAID 0/1
- MIL-STD-461 EMI Filter DC 9V~36V
- Extended Temperature: -40°C ~+60°C
- Size : 220x200x44 mm (W)x(D)x(H)

Specifications

SYSTEM

High performance Processor	Intel® Core™ i7-1370PE Processor (14 Cores / 20 Threads, 24M Cache, up to 4.80 GHz), 28W
Memory Type	DDR5 5200MHz / 1 x 260-pin SO-DIMM / Max. 32GB (Non-ECC)
Expansion Slot	1 x M.2 2280 M-Key (PCIe 4.0 x 4) 1 x Half Size mSATA/mPCIe x 1 (default: mSATA, select with BIOS)

DISPLAY

Chipset	Intel® Iris Xe Graphics
HDMI	HDMI 1.4 x 1, 3840 x 2160 @30Hz

STORAGE

SDD	SATAIII SSD– up to 2TB Capacity support RAID 0/1
-----	--

ETHERNET

Chipset	Intel® I219 Giga LAN + I226 2.5 Giga LAN
---------	--

FRONT I/O

X1	HDMI with D38999 connector
X2	2 x LAN with D38999 connector
X3	2 x USB2.0 +1x RS232/422/485 with D38999 connector
X4	9~36V DC-IN with D38999 connector
Button	Water Resistive Power Button with dual-color LED Backlight

REAR I/O

Ground Screw	1
--------------	---

POWER REQUIREMENT

Power Input	9V to 36V DC-IN support MIL-STD-461
Power Type	AT/ATX Mode Select by Jumper

APPLICATIONS, OPERATING SYSTEM

Applications	Military Platforms Requiring Compliance to MIL-STD-810 Embedded Computing, Process Control, Intelligent Automation and manufacturing applications where Harsh Temperature, Shock, Vibration, Altitude, Dust and EMI Conditions.
Operating System	Windows®11/10 64-bit, Linux(Support by request)

PHYSICAL

Dimension (W x D x H)	220 x 200 x 44 mm
Weight	2 Kg
Chassis	Aluminum AL6061
Heatsink	Aluminum Alloy, Corrosion Resistant.
Finish	Anodic aluminum oxide (Color)
Cooling	Natural Passive Convection/Conduction. No Moving Parts.
Ingress Protection	IP65

ENVIRONMENTAL

MIL-STD-461	CE102 basic curve, 10kHz - 30 MHz RE102-4, (1.5 MHz) -30 MHz - 5 GHz RS103, 1.5 MHz - 5 GHz, 50 V/m equal for all frequencies
MIL-STD-810 (Compliance)	Method 507.5, Procedure II (Temperature & Humidity) Method 516.6 Shock-Procedure V Non-Operating (Mechanical Shock) Method 516.6 Shock-Procedure I Operating (Mechanical Shock) Method 514.6 Vibration Category 24/Non-Operating (Category 20 & 24, Vibration) Method 514.6 Vibration Category 20/Operating (Category 20 & 24, Vibration) Method 501.5, Procedure I (Storage/High Temperature) Method 501.5, Procedure II (Operation/High Temperature) Method 502.5, Procedure I (Storage/Low Temperature) Method 502.5, Procedure II (Operation/Low Temperature) Method 503.5, Procedure I (Temperature shock).
Green Product	RoHS, WEEE compliance
Operating Temp.	-40 to 60°C
Storage Temp.	-40 to 85°C
Relative Humidity	5% to 95%, non-condensing.

Block Diagram

THOR100S-X13D

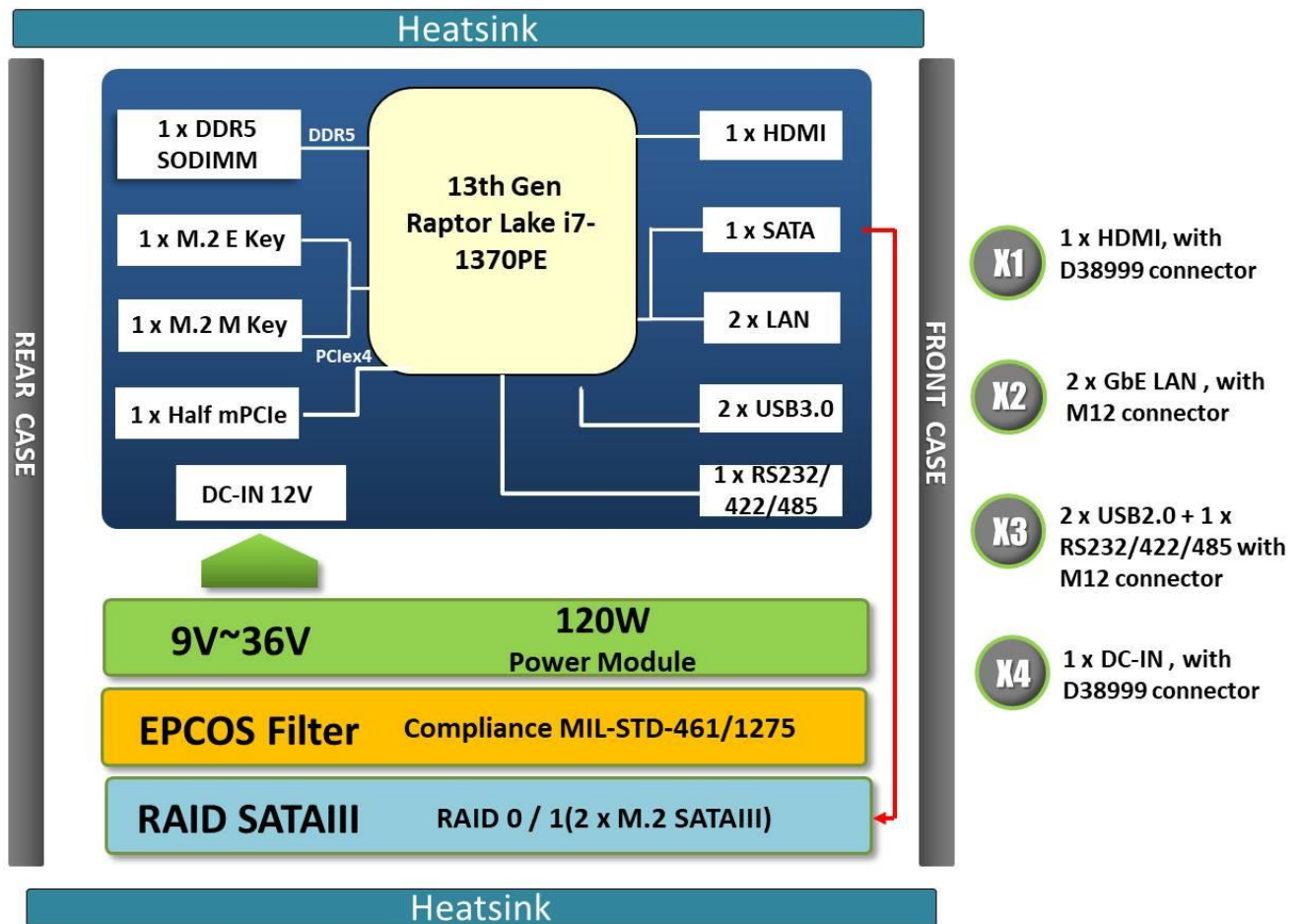

Ordering Information

THOR100S-X13D

Ultra-Slim Rugged SFF 1U/2 Military Computer with Intel® i7-1370PE , 9V to 36V DC-IN, Extended Temp -40 to 60°C

Appearance

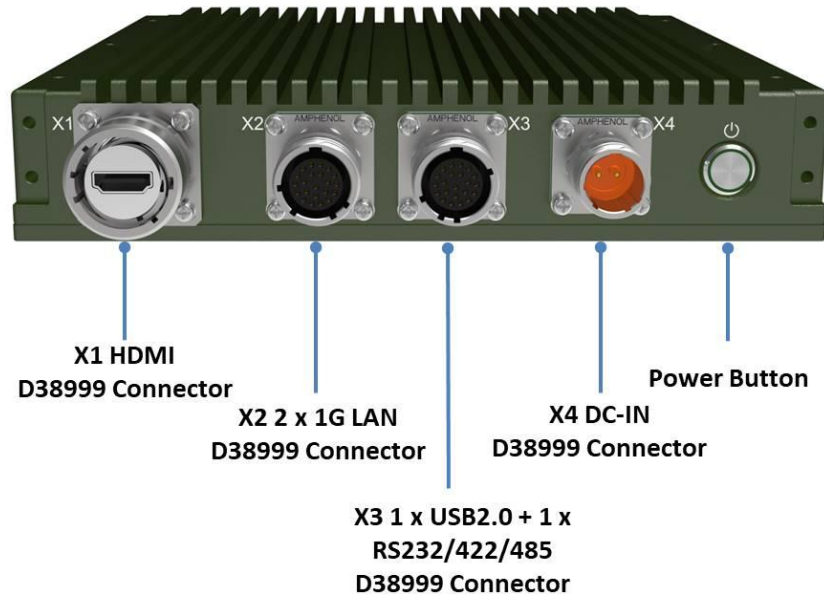

Dimension

