

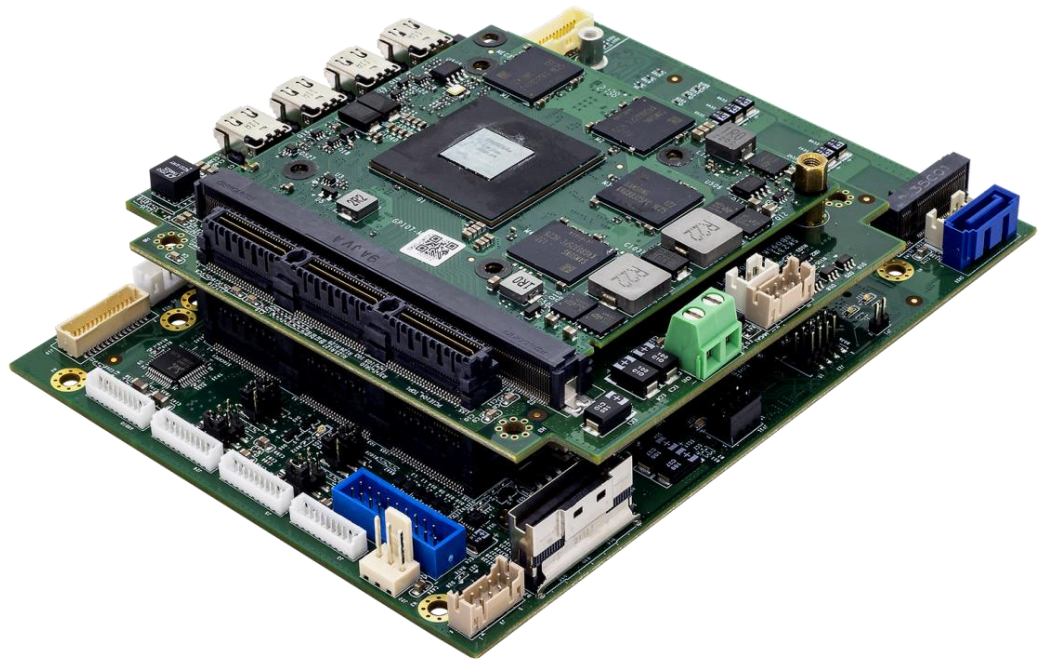

PCIe/104 – RH

PCIe/104 Processing Unit Intel 13th Raptor Lake (H)



- **PCI/104 Express Type2 Slot for Open Modular Architecture**
- **Standard MXM Type 3.1 Support NVIDIA QUADRO®GPU**
- **Intel 13th Raptor Lake-H Core-I Processor**
- **Multi-Expansions include Dual Mini PCIe Express Slots**
- **GPU can be targeted for 4 Mini Display port outputs**
- **Extreme Temperature Support -40 to 85°C**

Specifications

System

CPU Options	Intel® Core™ i7-13800HRE 45W Raptor Lake 13th Gen, 14C , Freq. 2.5 /5.0 GHz, 24MB cache Intel® Core™ i7-13800HE 45W Raptor Lake 13th Gen, 14C , Freq. 2.5 /5.0 GHz, 24MB cache
GPU Options	NVIDIA® Ampere RTX A1000, 35W, 4GB GDDR6, 2,048 CUDA Cores NVIDIA® Ampere RTX A2000, 36W/80W, 8GB GDDR6, 2,560 CUDA Cores NVIDIA® Ampere RTX A4500, 80W/130W, 16GB GDDR6, 5,888 CUDA Cores
Memory	DDR5 5200MHz SO-DIMM up to 96GB
MXM Carrier	SK232

Expansion

MiniPCIe Expansion	1x Full-size mini PCIe 1 1x Full-size mini PCIe 2
PCIe/104 Expansion(Type2)	2x PCIe x4 ; 4x PCIe x1
M.2	1x M.2 2280, PCIe x4
SlimSAS	1x SlimSAS 8i connector

Storage

SATAIII	1x SATAIII
---------	------------

Display

Mini DP	4x Mini Display Port outputs from GPU
VGA	1x VGA from GPU (SK231)(Option)
LVDS	1x Dual channel 18/24bit LVDS

Ethernet

Ethernet	Intel® I226-LM GbE LAN (10/100/1000Mbit /2.5G) Ethernet ports
Ethernet	GbE LAN from CPU module

I/O

USB	2x USB 3.0 2x USB2.0
COM Port	2x RS232/422/485

DIO	4x DI/ 4x DO
LPC	1x 10Pin
Audio	1x Line-out, 1x Mic-In

Power System

Input Power	9V~36V DC-IN 12V DC-IN for CPU FAN
Input Power by MXM carrier board	12V DC-IN for GPU FAN

Mechanical and Environment

Dimensions	148mm x 110mm
Operating Temperature	0°C to 55°C -40°C to 85°C (By Option)
Storage Temperature	-40 to 85°C
Relative Humidity	10% to 90%, non-condensing

Standard Compliance

Standard Compliance	CE/FCC
---------------------	--------

OS

OS Support	Windows®10 64bit Linux(Support by request)
------------	---

I/O Placement

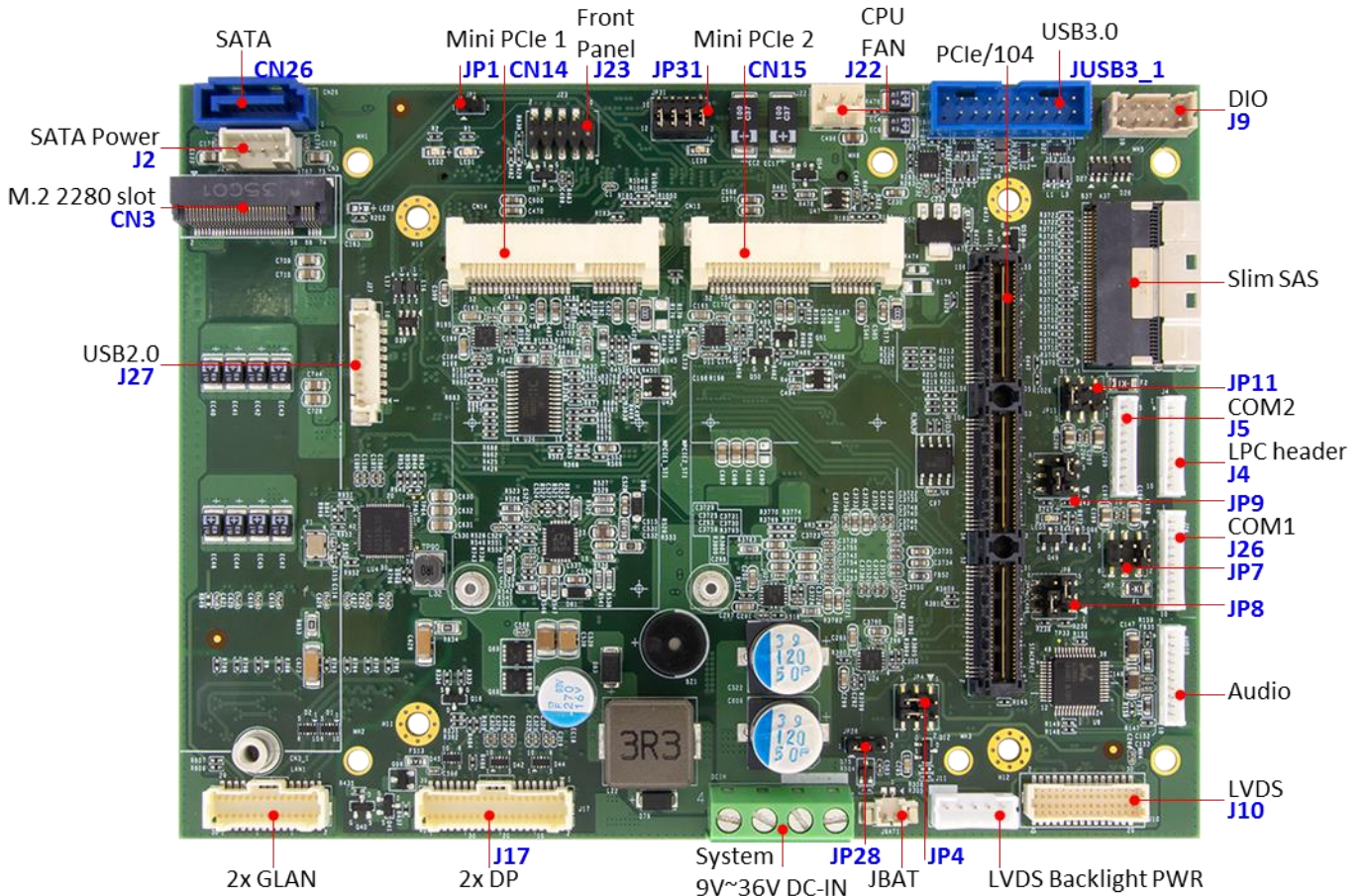
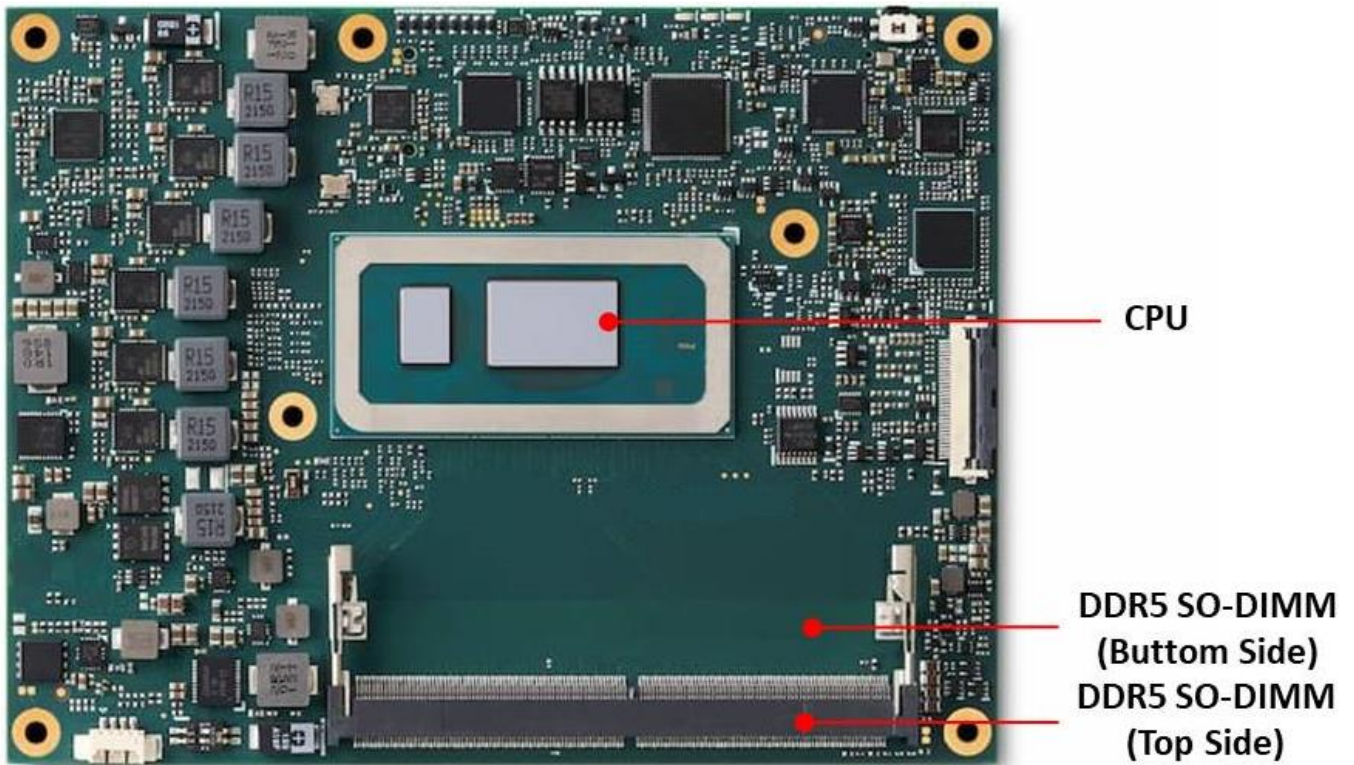

Stack Concept

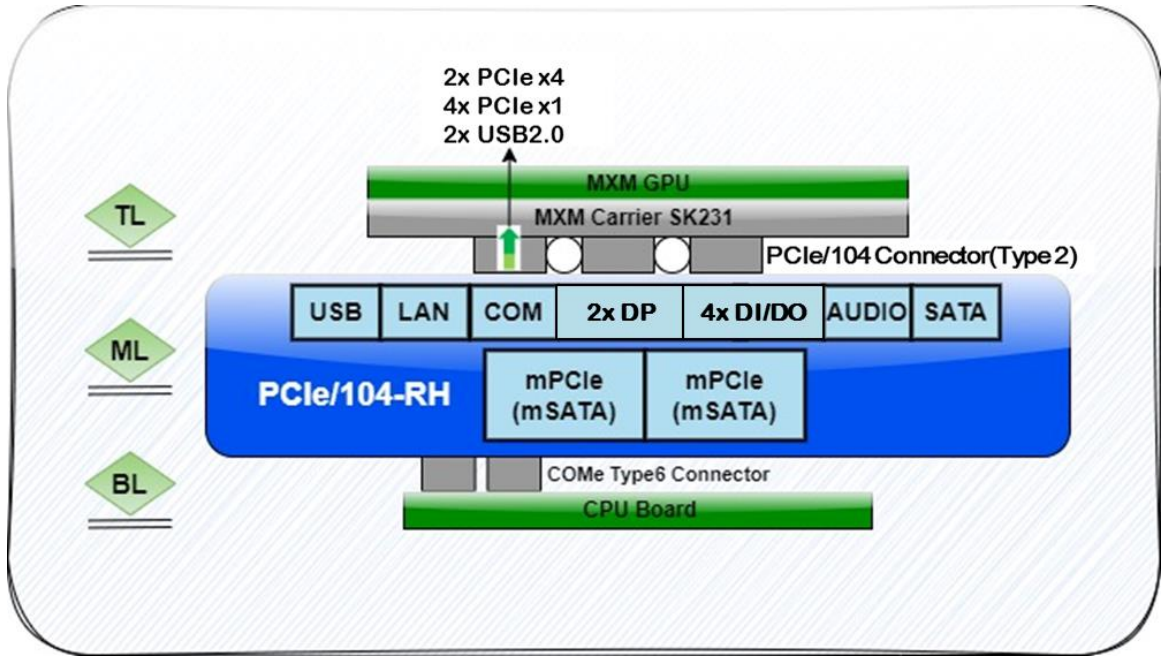

Block Diagram

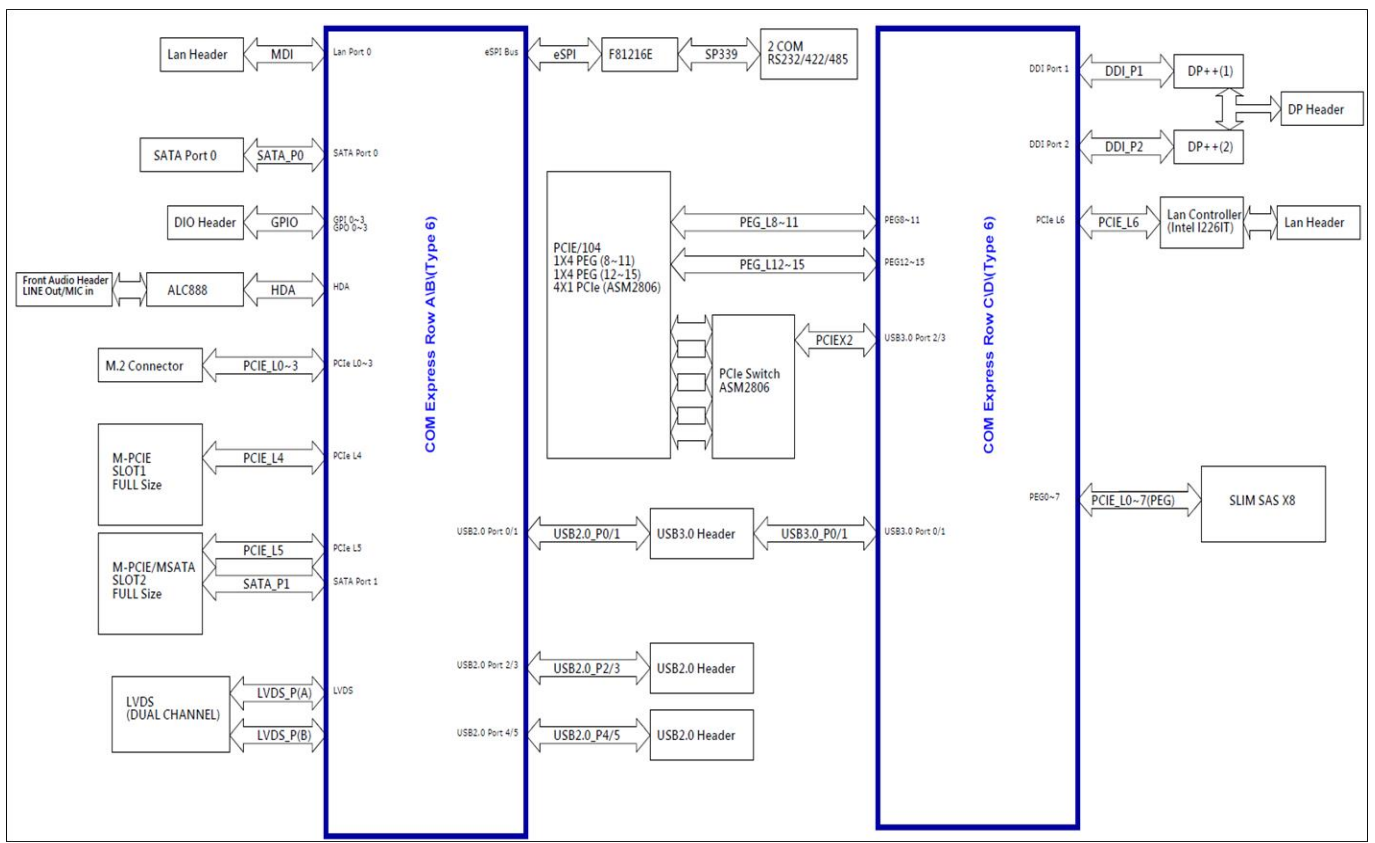

Ordering Information

Model Name Spec	PCIe104-RH01A10	PCIe104-RH01A20	PCIe104-RH01A45
PCIe/104 Form Factor	Type2		
CPU	13 th i7-13800HRE(45W)		
RAM	DDR5 SO-DIMM up to 64GB		
LAN	2x GbE		
GPU	RTX A1000	RTX A2000	RTX A4500
LVDS	1x LVDS		
DP	2x DP from CPU 4x mDP from MXM GPU		
SATA	1x SATAIII		
COM	2x RS232/422/485		
Power	System : 9V~36V DC-IN GPU : 12V DC-IN		
Operation Temp	0°C to 55°C -40°C to 85°C (By Option)		