



Test Report issued under the responsibility of:



TEST REPORT
IEC 62368-1
Audio/video, information and communication technology equipment
Part 1: Safety requirements

Report Number..... : TSSF2409000590B0

Date of issue : 2024-12-18

Total number of pages : 58

Name of Testing Laboratory preparing the Report : SGS Taiwan Ltd.

Applicant's name : PERFECTRON Co., Ltd. Taiwan Branch (B.V.I)

Address : 2F., No.190, Sec. 2, Zhongxing Rd., Xindian Dist., New Taipei City, 231, Taiwan.

Test specification:

Standard : IEC 62368-1:2018

Test procedure..... : CB Scheme

Non-standard test method..... : N/A

TRF template used : IECEE OD-2020-F1:2021, Ed.1.4

Test Report Form No..... : IEC62368_1E

Test Report Form(s) Originator.... : UL(US)

Master TRF : Dated 2022-04-14

Copyright © 2022 IEC System of Conformity Assessment Schemes for Electrotechnical Equipment and Components (IECEE System). All rights reserved.

This publication may be reproduced in whole or in part for non-commercial purposes as long as the IECEE is acknowledged as copyright owner and source of the material. IECEE takes no responsibility for and will not assume liability for damages resulting from the reader's interpretation of the reproduced material due to its placement and context.

If this Test Report Form is used by non-IECEE members, the IECEE/IEC logo and the reference to the CB Scheme procedure shall be removed.

This report is not valid as a CB Test Report unless signed by an approved CB Testing Laboratory and appended to a CB Test Certificate issued by an NCB in accordance with IECEE 02.

General disclaimer:

The test results presented in this report relate only to the object tested.
This report shall not be reproduced, except in full, without the written approval of the Issuing CB Testing Laboratory. The authenticity of this Test Report and its contents can be verified by contacting the NCB, responsible for this Test Report.

Test item description	SUBSTATION COMPUTER	
Trade Mark(s)	PERFECTRON	
Manufacturer	Same as applicant	
Model/Type reference	SCH4X2-A9	
Ratings	Input: 110-240 V~ 2.6A 50/60Hz	
Responsible Testing Laboratory (as applicable), testing procedure and testing location(s):		
<input checked="" type="checkbox"/> CB Testing Laboratory:	SGS Taiwan Ltd.	
Testing location/ address	No. 33, Wu Chyuan Road, New Taipei Industrial Park, Wu Ku District, New Taipei City 248, Taiwan	
Tested by (name, function, signature)	Andy Lee Project handler	
Approved by (name, function, signature) .. :	Kenny Cheng Reviewer	
Testing procedure: CTF Stage 1:		
Testing location/ address		
Tested by (name, function, signature)		
Approved by (name, function, signature) .. :		
Testing procedure: CTF Stage 2:		
Testing location/ address		
Tested by (name, function, signature)		
Witnessed by (name, function, signature) . :		
Approved by (name, function, signature) .. :		
Testing procedure: CTF Stage 3:		
Testing procedure: CTF Stage 4:		
Testing location/ address		
Tested by (name, function, signature)		
Witnessed by (name, function, signature) . :		
Approved by (name, function, signature) .. :		
Supervised by (name, function, signature) :		

List of Attachments (including a total number of pages in each attachment):	
Attachment 1: European Group Differences And National Differences (21 pages)	
Attachment 2: U.S.A. AND CANADA NATIONAL DIFFERENCES (9 pages)	
Attachment 3: Australia / New Zealand National Differences (33 pages)	
Attachment 4: CHINA NATIONAL DIFFERENCES (5 pages)	
Attachment 5: JAPAN NATIONAL DIFFERENCES (6 pages)	
Attachment 6: SAUDI ARABIA NATIONAL DIFFERENCES (1 page)	
Attachment 7: Photographs (7 pages)	
Summary of testing:	
The sample(s) tested complies with the requirements of IEC 62368-1:2018.	
The investigation of the product did not cover the functional characteristics of the equipment, only the safety aspects as laid out in IEC 62368-1 were subjected to the investigation.	
T _{ma} (max. ambient temperature permitted by the manufacturer's specification.) = 60 degree C	
T _{amb} (the ambient temperature under the test, if unless specified.) = 25 degree C	
The instructions shall contain a statement (See subclause F.4): This equipment intended only for use in a restricted access area and only for indoor use.	
Maximum normal load: The EUT operated under all connectors connected and transmit data continuously, each USB 3.0 / USB 3.2 port load 4.5 W (5 Vdc, 0.9A) and each USB 2.0 port load 2.5 W (5 Vdc, 0.5A).	
Tests performed (name of test and test clause):	Testing location:
4.4.3.2, T.5 Steady force test	See page 2
4.4.3.4, T.6 Impact test	
5.4.1.4, 6.3.2, 9.2, B.2.6 Temperature measurements	
5.4.8 Humidity conditioning	
5.4.9 Electric strength test	
5.6.6 Resistance of the protective bonding system	
5.7 Prospective touch voltage and touch current measurement	
6.2.2 Power source circuit classifications	
8.6.2.2 Static stability test	
B.2.5 Input test	
B.3 Simulated abnormal operating conditions	
B.4 Simulated single fault conditions	
F.3.10 Permanence of markings	
Annex M Batteries test	
Annex Q.1 Limited power source	

Summary of compliance with National Differences (List of countries addressed):

EU Group Differences, EU Special National Conditions, GB, US, CA, AU, NZ, CN, JP and SA.

List of countries addressed

CENELEC member countries (EU Group Differences, EU Special National Conditions): Austria, Belgium, Bulgaria, Croatia, Cyprus, the Czech Republic, Denmark, Estonia, Finland, France, Germany, Greece, Hungary, Iceland, Ireland, Italy, Latvia, Lithuania, Luxembourg, Malta, the Netherlands, Norway, Poland, Portugal, Republic of North Macedonia, Romania, Serbia, Slovakia, Slovenia, Spain, Sweden, Switzerland, Turkey.

United Kingdom (GB), United States (US), Canada (CA), Australia (AU), New Zealand (NZ), China (CN), Japan (JP) and Saudi Arabia (SA).

- The product fulfils the requirements of EN IEC 62368-1:2020+A11:2020
- The product fulfils the requirements of BS EN IEC 62368-1:2020+A11:2020
- The product fulfils the requirements of CSA/UL 62368-1:2019
- The product fulfils the requirements of AS/NZS 62368.1:2022
- The product fulfils the requirements of GB 4943.1-2022
- The product fulfils the requirements of J62368-1(2023)
- The product fulfils the requirements of SASO-IEC 62368-1:2020

For National Differences see corresponding Attachment.

Use of uncertainty of measurement for decisions on conformity (decision rule) :

No decision rule is specified by the IEC standard, when comparing the measurement result with the applicable limit according to the specification in that standard. The decisions on conformity are made without applying the measurement uncertainty ("simple acceptance" decision rule, previously known as "accuracy method").

Other:... (to be specified, for example when required by the standard or client, or if national accreditation requirements apply)

Information on uncertainty of measurement:

The uncertainties of measurement are calculated by the laboratory based on application of criteria given by OD-5014 for test equipment and application of test methods, decision sheets and operational procedures of IECEE.

IEC Guide 115 provides guidance on the application of measurement uncertainty principles and applying the decision rule when reporting test results within IECEE scheme, noting that the reporting of the measurement uncertainty for measurements is not necessary unless required by the test standard or customer.

Calculations leading to the reported values are on file with the NCB and testing laboratory that conducted the testing.

Copy of marking plate:

The artwork below may be only a draft. The use of certification marks on a product must be authorized by the respective NCBs that own these marks.

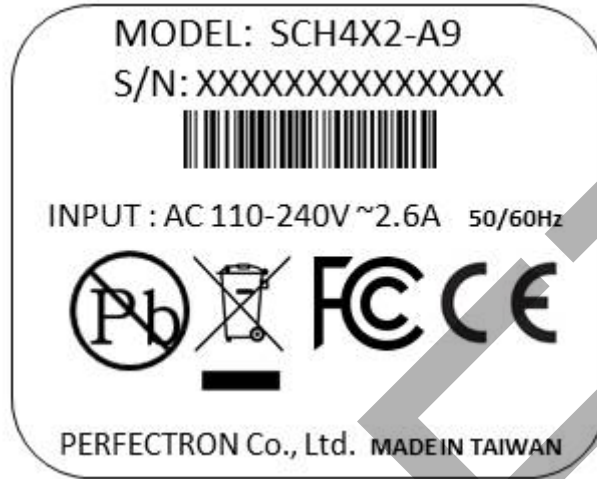

Test item particulars:			
Product group	<input checked="" type="checkbox"/> end product	<input type="checkbox"/> built-in component	
Classification of use by	<input type="checkbox"/> Ordinary person	<input type="checkbox"/> Children likely present	
	<input type="checkbox"/> Instructed person		
	<input checked="" type="checkbox"/> Skilled person		
Supply connection	<input checked="" type="checkbox"/> AC mains	<input type="checkbox"/> DC mains	
	<input type="checkbox"/> not mains connected:		
	<input type="checkbox"/> ES1	<input type="checkbox"/> ES2	<input type="checkbox"/> ES3
Supply tolerance	<input checked="" type="checkbox"/> +10%/-10%		
	<input type="checkbox"/> +20%/-15%		
	<input type="checkbox"/> + %/ - %		
	<input type="checkbox"/> None		
Supply connection – type	<input checked="" type="checkbox"/> pluggable equipment type A –		
	<input type="checkbox"/> non-detachable supply cord		
	<input checked="" type="checkbox"/> appliance coupler		
	<input type="checkbox"/> direct plug-in		
	<input type="checkbox"/> pluggable equipment type B –		
	<input type="checkbox"/> non-detachable supply cord		
	<input type="checkbox"/> appliance coupler		
	<input type="checkbox"/> permanent connection		
	<input type="checkbox"/> mating connector	<input type="checkbox"/> other:	
Considered current rating of protective device	<input checked="" type="checkbox"/> 16 or 20 A (for US and CA);		
	Location: <input checked="" type="checkbox"/> building	<input type="checkbox"/> equipment	
	<input type="checkbox"/> N/A		
Equipment mobility	<input checked="" type="checkbox"/> movable	<input type="checkbox"/> hand-held	<input type="checkbox"/> transportable
	<input type="checkbox"/> direct plug-in	<input type="checkbox"/> stationary	<input type="checkbox"/> for building-in
	<input type="checkbox"/> wall/ceiling-mounted	<input type="checkbox"/> SRME/rack-mounted	
	<input type="checkbox"/> other:		
Overvoltage category (OVC)	<input type="checkbox"/> OVC I	<input checked="" type="checkbox"/> OVC II	<input type="checkbox"/> OVC III
	<input type="checkbox"/> OVC IV	<input type="checkbox"/> other:	
Class of equipment	<input checked="" type="checkbox"/> Class I	<input type="checkbox"/> Class II	<input type="checkbox"/> Class III
	<input type="checkbox"/> Not classified		
Special installation location	<input type="checkbox"/> N/A	<input checked="" type="checkbox"/> restricted access area	
	<input type="checkbox"/> outdoor location		
Pollution degree (PD)	<input type="checkbox"/> PD 1	<input checked="" type="checkbox"/> PD 2	<input type="checkbox"/> PD 3
Manufacturer's specified T_{ma}	60 °C	<input type="checkbox"/> Outdoor: minimum	°C
IP protection class	<input checked="" type="checkbox"/> IPX0	<input type="checkbox"/> IP__	
Power systems	<input checked="" type="checkbox"/> TN	<input type="checkbox"/> TT	<input type="checkbox"/> IT - V _{L-L}
	<input type="checkbox"/> not AC mains		
Altitude during operation (m)	<input type="checkbox"/> 2000 m or less	<input checked="" type="checkbox"/> 5000 m	
Altitude of test laboratory (m)	<input checked="" type="checkbox"/> 2000 m or less	<input type="checkbox"/> m	
Mass of equipment (kg)	8.5 kg max.		

<p>Possible test case verdicts:</p> <p>- test case does not apply to the test object: N/A</p> <p>- test object does meet the requirement.....: P (Pass)</p> <p>- test object does not meet the requirement.....: F (Fail)</p>	
<p>Testing:</p> <p>Date of receipt of test item: 2024-09-06</p> <p>Date (s) of performance of tests: 2024-09-06 to 2024-10-14</p>	
<p>General remarks:</p> <p>“(See Enclosure #)” refers to additional information appended to the report. “(See appended table)” refers to a table appended to the report.</p> <p>Throughout this report a <input type="checkbox"/> comma / <input checked="" type="checkbox"/> point is used as the decimal separator.</p> <p>This document is issued by the Company subject to its General Conditions of Service printed overleaf, available on request or accessible at https://www.sgs.com.tw/terms-of-service and, for electronic format documents, subject to Terms and Conditions for Electronic Documents at http://www.sgs.com/en/Terms-and-Conditions/Terms-e-Documents.aspx</p> <p>Attention is drawn to the limitation of liability, indemnification and jurisdiction issues defined therein. Any holder of this document is advised that information contained hereon reflects the Company’s findings at the time of its intervention only and within the limits of Client’s instructions, if any. The Company’s sole responsibility is to its Client and this document does not exonerate parties to a transaction from exercising all their rights and obligations under the transaction documents. This document cannot be reproduced except in full, without prior written approval of the Company. Any unauthorized alteration, forgery or falsification of the content or appearance of this document is unlawful and offenders may be prosecuted to the fullest extent of the law.”</p> <p>Unless otherwise stated the results shown in this test report refer only to the sample(s) tested and such sample(s) are retained for 90 days only.</p> <p>All evaluation, test results and judgement in this report are based on information, documents and samples provided by applicant.</p>	
<p>Manufacturer’s Declaration per sub-clause 4.2.5 of IECCE 02:</p>	
<p>The application for obtaining a CB Test Certificate includes more than one factory location and a declaration from the Manufacturer stating that the sample(s) submitted for evaluation is (are) representative of the products from each factory has been provided</p>	<p><input type="checkbox"/> Yes</p> <p><input checked="" type="checkbox"/> Not applicable</p>
<p>When differences exist; they shall be identified in the General product information section.</p>	
<p>Name and address of factory (ies) : PERFECTRON Co., Ltd. Taiwan Branch (B.V.I)</p> <p style="text-align: right;">2F., No.190, Sec. 2, Zhongxing Rd., Xindian Dist., New Taipei City, 231, Taiwan.</p>	

General product information and other remarks:**Product Description –**

1. The equipment under test (EUT), model shown as page 2 is SUBSTATION COMPUTER for used with audio/video, information and communication technology equipment in the scope of this standard.
2. The equipment is incorporated with following critical parts:
 - 1) Metal enclosure covers all components.
 - 2) Main board (CPU with heatsink, Memory sticks, Heatsinks, RTC coin battery...etc).
 - 3) One certified Switching power supply (SPS).
 - 4) Two SSD provided.
3. The output data port has been evaluated complying with Annex Q.1 as a Limited Power Source.

Model Differences –

N/A

DRAFT

OVERVIEW OF ENERGY SOURCES AND SAFEGUARDS				
Clause	Possible Hazard			
5	Electrically-caused injury			
Class and Energy Source (e.g. ES3: Primary circuit)	Body Part (e.g. Ordinary)	Safeguards		
		B	S	R
ES3: Input and internal circuit of certified PSU	Skilled person	N/A	N/A	Enclosure, see 5.5.3 and 5.5.4
ES1: Output of certified PSU	Skilled person	N/A	N/A	N/A
6	Electrically-caused fire			
Class and Energy Source (e.g. PS2: 100 Watt circuit)	Material part (e.g. Printed board)	Safeguards		
		B	1 st S	2 nd S
PS3 circuit	Enclosure	See sub-clause 6.3	Metal	N/A
PS3 circuit	PCB	See sub-clause 6.3	V-1 or better	N/A
PS3 circuit	The other components/ combustible materials	See sub-clause 6.3	See sub-clauses 6.4.5 and 6.4.6	N/A
PS3 circuit	Internal wiring	N/A	N/A	See 6.5
PS2 circuit	Output connectors	See sub-clause 6.3	See sub-clauses 6.4.5	N/A
7	Injury caused by hazardous substances			
Class and Energy Source (e.g. Ozone)	Body Part (e.g., Skilled)	Safeguards		
		B	S	R
RTC coin battery (Lithium)	Skilled person	See Annex M	N/A	N/A
8	Mechanically-caused injury			
Class and Energy Source (e.g. MS3: Plastic fan blades)	Body Part (e.g. Ordinary)	Safeguards		
		B	S	R
MS1: No sharp edges and all corners are smooth.	Skilled person	N/A	N/A	N/A
MS2: Equipment mass > 7 kg ≤ 25 kg	Skilled person	Equipment safeguard	N/A	N/A
9	Thermal burn			
Class and Energy Source (e.g. TS1: Keyboard caps)	Body Part (e.g., Ordinary)	Safeguards		
		B	S	R
TS1: Accessible parts	Skilled person	N/A	N/A	N/A
10	Radiation			
Class and Energy Source (e.g. RS1: PMP sound output)	Body Part (e.g., Ordinary)	Safeguards		
		B	S	R
RS1: LED (indicating light)	Skilled person	N/A	N/A	N/A

Supplementary Information:

“B” – Basic Safeguard; “S” – Supplementary Safeguard; “R” – Reinforced Safeguard

DRAFT

ENERGY SOURCE DIAGRAM

Optional. Manufacturers are to provide the energy sources diagram identify declared energy sources and identifying the demarcations are between power sources. Recommend diagram be provided included in power supply and multipart systems.

Insert diagram below. Example diagram designs are; Block diagrams; image(s) with layered data; mechanical drawings

See “**OVERVIEW OF ENERGY SOURCES AND SAFEGUARDS**”

ES PS MS TS RS

IEC 62368-1			
Clause	Requirement + Test	Result - Remark	Verdict
4	GENERAL REQUIREMENTS		—
4.1.1	Acceptance of materials, components and subassemblies	See appended Table 4.1.2	P
4.1.2	Use of components	Components which are certified to IEC and/or national standards are used correctly within their ratings. Components not covered by IEC standards are tested under the conditions presented in the equipment.	P
4.1.3	Equipment design and construction	No accessible part which could cause injury. However, the equipment is building-in type, evaluation is to be made during the final system.	P
4.1.4	Specified ambient temperature for outdoor use (°C) :	Not outdoor use.	N/A
4.1.5	Constructions and components not specifically covered	Not involves.	N/A
4.1.8	Liquids and liquid filled components (LFC)	No liquids.	N/A
4.1.15	Markings and instructions	(See Annex F)	P
4.4.3	Safeguard robustness	All safeguards comply with the relevant robustness tests and requirement.	P
4.4.3.1	General	See below.	P
4.4.3.2	Steady force tests	(See Annex T.5)	P
4.4.3.3	Drop tests		N/A
4.4.3.4	Impact tests	(See Annex T.6)	P
4.4.3.5	Internal accessible safeguard tests		N/A
4.4.3.6	Glass impact tests	No such parts.	N/A
4.4.3.7	Glass fixation tests		N/A
	Glass impact test (1J)		N/A
	Push/pull test (10 N)		N/A
4.4.3.8	Thermoplastic material tests	No such parts.	N/A
4.4.3.9	Air comprising a safeguard	No such parts.	N/A
4.4.3.10	Accessibility, glass, safeguard effectiveness		N/A
4.4.4	Displacement of a safeguard by an insulating liquid	No such parts.	N/A
4.4.5	Safety interlocks	No such parts.	N/A
4.5	Explosion		P

IEC 62368-1			
Clause	Requirement + Test	Result - Remark	Verdict
4.5.1	General	See below.	P
4.5.2	No explosion during normal/abnormal operating condition	See appended table B.2 and B.3.	P
	No harm by explosion during single fault conditions	See appended table B.4.	N/A
4.6	Fixing of conductors	No such parts.	N/A
	Fix conductors not to defeat a safeguard		N/A
	Compliance is checked by test..... :		N/A
4.7	Equipment for direct insertion into mains socket-outlets		N/A
4.7.2	Mains plug part complies with relevant standard .. :	No such parts.	N/A
4.7.3	Torque (Nm)		N/A
4.8	Equipment containing coin/button cell batteries		N/A
4.8.1	General	The children are unlikely present in the equipment location.	N/A
4.8.2	Instructional safeguard		N/A
4.8.3	Battery compartment door/cover construction		N/A
	Open torque test		N/A
4.8.4.2	Stress relief test		N/A
4.8.4.3	Battery replacement test		N/A
4.8.4.4	Drop test		N/A
4.8.4.5	Impact test		N/A
4.8.4.6	Crush test		N/A
4.8.5	Compliance		N/A
	30N force test with test probe		N/A
	20N force test with test hook		N/A
4.9	Likelihood of fire or shock due to entry of conductive object		P
4.10	Component requirements		P
4.10.1	Disconnect Device	(See Annex L)	P
4.10.2	Switches and relays	No such parts.	N/A
5	ELECTRICALLY-CAUSED INJURY		—
5.2	Classification and limits of electrical energy sources		P
5.2.2	ES1, ES2 and ES3 limits	Evaluated in certified switching power supply.	P
5.2.2.2	Steady-state voltage and current limits		N/A
5.2.2.3	Capacitance limits		N/A
5.2.2.4	Single pulse limits		N/A

IEC 62368-1			
Clause	Requirement + Test	Result - Remark	Verdict
5.2.2.5	Limits for repetitive pulses		N/A
5.2.2.6	Ringling signals		N/A
5.2.2.7	Audio signals		N/A
5.3	Protection against electrical energy sources		P
5.3.1	General Requirements for accessible parts to ordinary, instructed and skilled persons	Compliance.	P
5.3.1 a)	Accessible ES1/ES2 derived from ES2/ES3 circuits		P
5.3.1 b)	Skilled persons not unintentional contact ES3 bare conductors		P
5.3.2.1	Accessibility to electrical energy sources and safeguards	Compliance.	P
	Accessibility to outdoor equipment bare parts	Not outdoor equipment.	N/A
5.3.2.2	Contact requirements	See below.	P
	Test with test probe from Annex V	The test probe of Figure V.1 and V.2 cannot access the hazardous live part.	—
5.3.2.2 a)	Air gap – electric strength test potential (V)		N/A
5.3.2.2 b)	Air gap – distance (mm)		N/A
5.3.2.3	Compliance		N/A
5.3.2.4	Terminals for connecting stripped wire		N/A
5.4	Insulation materials and requirements		P
5.4.1.2	Properties of insulating material	See below.	P
5.4.1.3	Material is non-hygroscopic	(See sub-clause 5.4.8)	P
5.4.1.4	Maximum operating temperature for insulating materials	(See appended table 5.4.1.4, 6.3.2, 9.0, B.2.6)	P
5.4.1.5	Pollution degrees	PD2	—
5.4.1.5.2	Test for pollution degree 1 environment and for an insulating compound		N/A
5.4.1.5.3	Thermal cycling test		N/A
5.4.1.6	Insulation in transformers with varying dimensions		N/A
5.4.1.7	Insulation in circuits generating starting pulses		N/A
5.4.1.8	Determination of working voltage	Evaluated in certified switching power supply.	P
5.4.1.9	Insulating surfaces		N/A
5.4.1.10	Thermoplastic parts on which conductive metallic parts are directly mounted	Evaluated in certified switching power supply.	P
5.4.1.10.2	Vicat test.....		N/A
5.4.1.10.3	Ball pressure test		N/A

IEC 62368-1			
Clause	Requirement + Test	Result - Remark	Verdict
5.4.2	Clearances	Evaluated in certified switching power supply.	P
5.4.2.1	General requirements		N/A
	Clearances in circuits connected to AC Mains, Alternative method		N/A
5.4.2.2	Procedure 1 for determining clearance		N/A
	Temporary overvoltage		—
5.4.2.3	Procedure 2 for determining clearance		N/A
5.4.2.3.2.2	a.c. mains transient voltage		—
5.4.2.3.2.3	d.c. mains transient voltage		—
5.4.2.3.2.4	External circuit transient voltage.....		—
5.4.2.3.2.5	Transient voltage determined by measurement		—
5.4.2.4	Determining the adequacy of a clearance using an electric strength test		N/A
5.4.2.5	Multiplication factors for clearances and test voltages	Evaluated in certified switching power supply.	P
5.4.2.6	Clearance measurement	Evaluated in certified switching power supply.	P
5.4.3	Creepage distances	Evaluated in certified switching power supply.	P
5.4.3.1	General		N/A
5.4.3.3	Material group		—
5.4.3.4	Creepage distances measurement		N/A
5.4.4	Solid insulation	Evaluated in certified switching power supply.	P
5.4.4.1	General requirements		N/A
5.4.4.2	Minimum distance through insulation		N/A
5.4.4.3	Insulating compound forming solid insulation		N/A
5.4.4.4	Solid insulation in semiconductor devices		N/A
5.4.4.5	Insulating compound forming cemented joints		N/A
5.4.4.6	Thin sheet material		N/A
5.4.4.6.1	General requirements		N/A
5.4.4.6.2	Separable thin sheet material		N/A
	Number of layers (pcs)		N/A
5.4.4.6.3	Non-separable thin sheet material		N/A
	Number of layers (pcs)		N/A
5.4.4.6.4	Standard test procedure for non-separable thin sheet material		N/A

IEC 62368-1			
Clause	Requirement + Test	Result - Remark	Verdict
5.4.4.6.5	Mandrel test		N/A
5.4.4.7	Solid insulation in wound components		N/A
5.4.4.9	Solid insulation at frequencies >30 kHz, E_P , K_R , d , V_{PW} (V)		N/A
	Alternative by electric strength test, tested voltage (V), K_R		N/A
5.4.5	Antenna terminal insulation	No such parts.	N/A
5.4.5.1	General		N/A
5.4.5.2	Voltage surge test		N/A
5.4.5.3	Insulation resistance (M Ω)		N/A
	Electric strength test		N/A
5.4.6	Insulation of internal wire as part of supplementary safeguard	No such parts.	N/A
5.4.7	Tests for semiconductor components and for cemented joints	Certified optocouplers used in certified switching power supply.	N/A
5.4.8	Humidity conditioning	See below.	P
	Relative humidity (%), temperature ($^{\circ}$ C), duration (h)	93 %, 40 $^{\circ}$ C, 120 h	—
5.4.9	Electric strength test	(See appended table 5.4.9)	P
5.4.9.1	Test procedure for type test of solid insulation	Compliance was checked immediately following temperature test in subclause 5.4.1.4	P
5.4.9.2	Test procedure for routine test		N/A
5.4.10	Safeguards against transient voltages from external circuits	No such circuits.	N/A
5.4.10.1	Parts and circuits separated from external circuits		N/A
5.4.10.2	Test methods		N/A
5.4.10.2.1	General		N/A
5.4.10.2.2	Impulse test		N/A
5.4.10.2.3	Steady-state test		N/A
5.4.10.3	Verification for insulation breakdown for impulse test		N/A
5.4.11	Separation between external circuits and earth	No such parts.	N/A
5.4.11.1	Exceptions to separation between external circuits and earth		N/A
5.4.11.2	Requirements		N/A
	SPDs bridge separation between external circuit and earth		N/A

IEC 62368-1			
Clause	Requirement + Test	Result - Remark	Verdict
	Rated operating voltage U_{op} (V)..... :		—
	Nominal voltage U_{peak} (V)..... :		—
	Max increase due to variation ΔU_{sp} :		—
	Max increase due to ageing ΔU_{sa} :		—
5.4.11.3	Test method and compliance..... :		N/A
5.4.12	Insulating liquid	No such parts.	N/A
5.4.12.1	General requirements		N/A
5.4.12.2	Electric strength of an insulating liquid..... :		N/A
5.4.12.3	Compatibility of an insulating liquid..... :		N/A
5.4.12.4	Container for insulating liquid..... :		N/A
5.5	Components as safeguards		P
5.5.1	General	See below.	P
5.5.2	Capacitors and RC units	Evaluated in certified switching power supply.	P
5.5.2.1	General requirement	See 5.5.2	P
5.5.2.2	Safeguards against capacitor discharge after disconnection of a connector..... :	See 5.5.2	P
5.5.3	Transformers	Evaluated in certified switching power supply.	P
5.5.4	Optocouplers	Evaluated in certified switching power supply.	P
5.5.5	Relays	No relays.	N/A
5.5.6	Resistors	Approval bleeder resistors are used in certified switching power supply.	N/A
5.5.7	SPDs	No SPD's.	N/A
5.5.8	Insulation between the mains and an external circuit consisting of a coaxial cable..... :		N/A
5.5.9	Safeguards for socket-outlets in outdoor equipment		N/A
	RCD rated residual operating current (Ma)..... :		—
5.6	Protective conductor		P
5.6.2	Requirement for protective conductors	See below.	P
5.6.2.1	General requirements	Evaluated in certified switching power supply.	P
5.6.2.2	Colour of insulation	A green-and-yellow wire used for protective bonding conductor.	P

IEC 62368-1			
Clause	Requirement + Test	Result - Remark	Verdict
5.6.3	Requirement for protective earthing conductors	An appliance inlet provided that is connected by an approved appliance coupler serves as main protective earthing conductor terminal.	N/A
	Protective earthing conductor size (mm ²)	No power supply cord is provided.	—
	Protective earthing conductor serving as a reinforced safeguard		N/A
	Protective earthing conductor serving as a double safeguard		N/A
5.6.4	Requirements for protective bonding conductors	See below.	P
5.6.4.1	Protective bonding conductors	Complies with table G.5.	P
	Protective bonding conductor size (mm ²).	Protective bonding wire, 18 AWG, 0.75 mm ² .	—
5.6.4.2	Protective current rating (A).....	16 A (20 A for US and CA)	P
5.6.5	Terminals for protective conductors	Approval appliance inlet used.	P
5.6.5.1	Terminal size for connecting protective earthing conductors (mm).....		N/A
	Terminal size for connecting protective bonding conductors (mm)		N/A
5.6.5.2	Corrosion	No combination above the line in Annex N is used.	P
5.6.6	Resistance of the protective bonding system	See below.	P
5.6.6.1	Requirements		P
5.6.6.2	Test Method.....	Compliance checked.	P
5.6.6.3	Resistance (Ω) or voltage drop.....	(See appended table 5.6.6.2)	P
5.6.7	Reliable connection of a protective earthing conductor	The equipment is not permanently connected equipment.	N/A
5.6.8	Functional earthing		N/A
	Conductor size (mm ²).....		N/A
	Class II with functional earthing marking		N/A
	Appliance inlet cl & cr (mm)		N/A
5.7	Prospective touch voltage, touch current and protective conductor current		P
5.7.2	Measuring devices and networks		P
5.7.2.1	Measurement of touch current		P
5.7.2.2	Measurement of voltage		P
5.7.3	Equipment set-up, supply connections and earth connections	Considered.	P
5.7.4	Unearthed accessible parts	(See appended table 5.7.4)	P

IEC 62368-1			
Clause	Requirement + Test	Result - Remark	Verdict
5.7.5	Earthed accessible conductive parts	(See appended table 5.7.5)	P
5.7.6	Requirements when touch current exceeds ES2 limits	Not applicable, the touch current does not exceed ES2 limit.	N/A
	Protective conductor current (Ma)		N/A
	Instructional Safeguard.....		N/A
5.7.7	Prospective touch voltage and touch current associated with external circuits	The equipment does not contain the external circuits.	N/A
5.7.7.1	Touch current from coaxial cables		N/A
5.7.7.2	Prospective touch voltage and touch current associated with paired conductor cables		N/A
5.7.8	Summation of touch currents from external circuits	The equipment does not contain the external circuits.	N/A
	a) Equipment connected to earthed external circuits, current (Ma)		N/A
	b) Equipment connected to unearthed external circuits, current (Ma)		N/A
5.8	Backfeed safeguard in battery backed up supplies		N/A
	Mains terminal ES	No such parts.	N/A
	Air gap (mm).....		N/A

IEC 62368-1			
Clause	Requirement + Test	Result - Remark	Verdict
6	ELECTRICALLY- CAUSED FIRE		—
6.2	Classification of PS and PIS		P
6.2.2	Power source circuit classifications	All internal circuit considered as PS3 except power switch. (See appended Table 6.2.2)	P
6.2.3	Classification of potential ignition sources	See below.	P
6.2.3.1	Arcing PIS	Primary circuits are considered as arcing PIS.	P
6.2.3.2	Resistive PIS	All components located within the equipment are considered as resistive PIS. No further test considered necessary	P
6.3	Safeguards against fire under normal operating and abnormal operating conditions		P
6.3.1	No ignition and attainable temperature value less than 90 % defined by ISO 871 or less than 300 °C for unknown materials	During the test, no ignition occurred, or component's temperature reach to 300 °C of spontaneous ignition point.	P
	Combustible materials outside fire enclosure	No such parts.	N/A
6.4	Safeguards against fire under single fault conditions		P
6.4.1	Safeguard method	Method of "control of fire spread" is used.	P
6.4.2	Reduction of the likelihood of ignition under single fault conditions in PS1 circuits		N/A
6.4.3	Reduction of the likelihood of ignition under single fault conditions in PS2 and PS3 circuits		N/A
6.4.3.1	Supplementary safeguards		N/A
6.4.3.2	Single Fault Conditions		N/A
	Special conditions for temperature limited by fuse		N/A
6.4.4	Control of fire spread in PS1 circuits		N/A
6.4.5	Control of fire spread in PS2 circuits	See below.	P
6.4.5.2	Supplementary safeguards	Components other than PCB and wires are: - mounted on PCB min, V-1 or - made of V-2/ VTM-2 or better. (See appended Table 4.1.2 and Annex G)	P
6.4.6	Control of fire spread in PS3 circuits	Fire enclosure of clause 6.4.8 is provided with equipment.	P
6.4.7	Separation of combustible materials from a PIS	See below.	P

IEC 62368-1			
Clause	Requirement + Test	Result - Remark	Verdict
6.4.7.2	Separation by distance	All components and combustible materials other than small parts are either rated at least V-2 class material or mounted on PCB material with rated min. V-1 class material.	P
6.4.7.3	Separation by a fire barrier		N/A
6.4.8	Fire enclosures and fire barriers	Equipment metal enclosure was evaluated as a fire enclosure.	P
6.4.8.2	Fire enclosure and fire barrier material properties	See below.	P
6.4.8.2.1	Requirements for a fire barrier		N/A
6.4.8.2.2	Requirements for a fire enclosure	Equipment fire enclosure was made of metal.	P
6.4.8.3	Constructional requirements for a fire enclosure and a fire barrier	See below.	P
6.4.8.3.1	Fire enclosure and fire barrier openings	See below.	P
6.4.8.3.2	Fire barrier dimensions		N/A
6.4.8.3.3	Top openings and properties	See below.	P
	Openings dimensions (mm)..... :	No openings.	P
6.4.8.3.4	Bottom openings and properties	See below.	P
	Openings dimensions (mm)..... :	No openings.	P
	Flammability tests for the bottom of a fire enclosure		N/A
	Instructional Safeguard..... :		N/A
6.4.8.3.5	Side openings and properties	See below.	P
	Openings dimensions (mm)..... :	No openings.	P
6.4.8.3.6	Integrity of a fire enclosure, condition met: a), b) or c)..... :		N/A
6.4.8.4	Separation of a PIS from a fire enclosure and a fire barrier distance (mm) or flammability rating..... :		N/A
6.4.9	Flammability of insulating liquid..... :		N/A
6.5	Internal and external wiring		P
6.5.1	General requirements	VW-1 wire used. The test method described IEC60695-11-21.	P
6.5.2	Requirements for interconnection to building wiring..... :	No such parts.	N/A
6.5.3	Internal wiring size (mm ²) for socket-outlets..... :	No such parts.	N/A
6.6	Safeguards against fire due to the connection to additional equipment		P

IEC 62368-1			
Clause	Requirement + Test	Result - Remark	Verdict
7	INJURY CAUSED BY HAZARDOUS SUBSTANCES		—
7.2	Reduction of exposure to hazardous substances		N/A
7.3	Ozone exposure		N/A
7.4	Use of personal safeguards or personal protective equipment (PPE)		N/A
	Personal safeguards and instructions	No such parts.	—
7.5	Use of instructional safeguards and instructions		N/A
	Instructional safeguard (ISO 7010).....	No such parts.	—
7.6	Batteries and their protection circuits		P

8	MECHANICALLY-CAUSED INJURY		—
8.2	Mechanical energy source classifications		P
8.3	Safeguards against mechanical energy sources		P
8.4	Safeguards against parts with sharp edges and corners		P
8.4.1	Safeguards	MS1	P
	Instructional Safeguard.....		N/A
8.4.2	Sharp edges or corners	No Sharp edges or corners.	P
8.5	Safeguards against moving parts		N/A
8.5.1	Fingers, jewellery, clothing, hair, etc., contact with MS2 or MS3 parts	No such parts.	N/A
	MS2 or MS3 part required to be accessible for the function of the equipment		N/A
	Moving MS3 parts only accessible to skilled person		N/A
8.5.2	Instructional safeguard.....		N/A
8.5.4	Special categories of equipment containing moving parts		N/A
8.5.4.1	General		N/A
8.5.4.2	Equipment containing work cells with MS3 parts		N/A
8.5.4.2.1	Protection of persons in the work cell		N/A
8.5.4.2.2	Access protection override		N/A
8.5.4.2.2.1	Override system		N/A
8.5.4.2.2.2	Visual indicator		N/A
8.5.4.2.3	Emergency stop system		N/A
	Maximum stopping distance from the point of activation (m).....		N/A
	Space between end point and nearest fixed mechanical part (mm)		N/A
8.5.4.2.4	Endurance requirements		N/A

IEC 62368-1			
Clause	Requirement + Test	Result - Remark	Verdict
	Mechanical system subjected to 100 000 cycles of operation		N/A
	- Mechanical function check and visual inspection		N/A
	- Cable assembly		N/A
8.5.4.3	Equipment having electromechanical device for destruction of media		N/A
8.5.4.3.1	Equipment safeguards		N/A
8.5.4.3.2	Instructional safeguards against moving parts		N/A
8.5.4.3.3	Disconnection from the supply		N/A
8.5.4.3.4	Cut type and test force (N).....		N/A
8.5.4.3.5	Compliance		N/A
8.5.5	High pressure lamps		N/A
	Explosion test.....		N/A
8.5.5.3	Glass particles dimensions (mm)		N/A
8.6	Stability of equipment		P
8.6.1	General	See 8.6.2.2	P
	Instructional safeguard.....	Not television sets.	N/A
8.6.2	Static stability	See below.	P
8.6.2.2	Static stability test	Test with angle of 10°	P
8.6.2.3	Downward force test		N/A
8.6.3	Relocation stability		N/A
	Wheels diameter (mm)		—
	Tilt test		N/A
8.6.4	Glass slide test		N/A
8.6.5	Horizontal force test		N/A
8.7	Equipment mounted to wall, ceiling or other structure		N/A
8.7.1	Mount means type	No such parts.	N/A
8.7.2	Test methods		N/A
	Test 1, additional downwards force (N).....		N/A
	Test 2, number of attachment points and test force (N).....		N/A
	Test 3 Nominal diameter (mm) and applied torque (Nm).....		N/A
8.8	Handles strength		N/A
8.8.1	General	No such parts.	N/A
8.8.2	Handle strength test		N/A

IEC 62368-1			
Clause	Requirement + Test	Result - Remark	Verdict
	Number of handles.....:		—
	Force applied (N)		—
8.9	Wheels or casters attachment requirements		N/A
8.9.2	Pull test	No such parts.	N/A
8.10	Carts, stands and similar carriers		N/A
8.10.1	General	No such parts.	N/A
8.10.2	Marking and instructions.....:		N/A
8.10.3	Cart, stand or carrier loading test		N/A
	Loading force applied (N)		N/A
8.10.4	Cart, stand or carrier impact test		N/A
8.10.5	Mechanical stability		N/A
	Force applied (N)		—
8.10.6	Thermoplastic temperature stability		N/A
8.11	Mounting means for slide-rail mounted equipment (SRME)		N/A
8.11.1	General	No such parts.	N/A
8.11.2	Requirements for slide rails		N/A
	Instructional Safeguard.....:		N/A
8.11.3	Mechanical strength test		N/A
8.11.3.1	Downward force test, force (N) applied.....:		N/A
8.11.3.2	Lateral push force test		N/A
8.11.3.3	Integrity of slide rail end stops		N/A
8.11.4	Compliance		N/A
8.12	Telescoping or rod antennas		N/A
	Button/ball diameter (mm)	No such parts.	—
9	THERMAL BURN INJURY		—
9.2	Thermal energy source classifications		P
9.3	Touch temperature limits		P
9.3.1	Touch temperatures of accessible parts	All accessible surfaces are classified as TS1. (See appended table 5.4.1.4, 9.3, B.1.5, B.2.6, B.3, B.4)	P
9.3.2	Test method and compliance	See above.	P
9.4	Safeguards against thermal energy sources		N/A
9.5	Requirements for safeguards		N/A
9.5.1	Equipment safeguard	TS1	N/A

IEC 62368-1			
Clause	Requirement + Test	Result - Remark	Verdict
9.5.2	Instructional safeguard.....:		N/A
9.6	Requirements for wireless power transmitters		N/A
9.6.1	General	No such parts.	N/A
9.6.2	Specification of the foreign objects		N/A
9.6.3	Test method and compliance		N/A

10	RADIATION		—
10.2	Radiation energy source classification		P
10.2.1	General classification	LED indicator is considered as RS1.	P
	Lasers		—
	Lamps and lamp systems		—
	Image projectors		—
	X-Ray		—
	Personal music player		—
10.3	Safeguards against laser radiation		N/A
	The standard(s) equipment containing laser(s) comply		N/A
10.4	Safeguards against optical radiation from lamps and lamp systems (including LED types)		N/A
10.4.1	General requirements	See 10.2.1	N/A
	Instructional safeguard provided for accessible radiation level needs to exceed		N/A
	Risk group marking and location		N/A
	Information for safe operation and installation		N/A
10.4.2	Requirements for enclosures		N/A
	UV radiation exposure		N/A
10.4.3	Instructional safeguard		N/A
10.5	Safeguards against X-radiation		N/A
10.5.1	Requirements	No such parts.	N/A
	Instructional safeguard for skilled persons		—
10.5.3	Maximum radiation (Pa/kg).....:		—
10.6	Safeguards against acoustic energy sources		N/A
10.6.1	General	No such parts.	N/A
10.6.2	Classification		N/A
	Acoustic output $L_{Aeq,T}$, Db(A)		N/A
	Unweighted RMS output voltage (Mv)		N/A

IEC 62368-1			
Clause	Requirement + Test	Result - Remark	Verdict
	Digital output signal (Dbfs).....:		N/A
10.6.3	Requirements for dose-based systems		N/A
10.6.3.1	General requirements		N/A
10.6.3.2	Dose-based warning and automatic decrease		N/A
10.6.3.3	Exposure-based warning and requirements		N/A
	30 s integrated exposure level (MEL30)		N/A
	Warning for MEL \geq 100 Db(A)		N/A
10.6.4	Measurement methods		N/A
10.6.5	Protection of persons		N/A
	Instructional safeguards		N/A
10.6.6	Requirements for listening devices (headphones, earphones, etc.)		N/A
10.6.6.1	Corded listening devices with analogue input		N/A
	Listening device input voltage (Mv)		N/A
10.6.6.2	Corded listening devices with digital input		N/A
	Max. acoustic output $L_{Aeq,T}$, Db(A).....:		N/A
10.6.6.3	Cordless listening devices		N/A
	Max. acoustic output $L_{Aeq,T}$, Db(A).....:		N/A

B	NORMAL OPERATING CONDITION TESTS, ABNORMAL OPERATING CONDITION TESTS AND SINGLE FAULT CONDITION TESTS		—
B.1	General		P
B.1.5	Temperature measurement conditions	(See appended table B.1.5)	P
B.2	Normal operating conditions		P
B.2.1	General requirements.....:	(See Test Item Particulars and appended test tables)	P
	Audio Amplifiers and equipment with audio amplifiers	No amplifiers.	N/A
B.2.3	Supply voltage and tolerances	(See Test Item Particulars and appended test tables)	P
B.2.5	Input test.....:	(See appended table B.2.5)	P
B.3	Simulated abnormal operating conditions		P
B.3.1	General	See below.	P
B.3.2	Covering of ventilation openings	No openings.	N/A
	Instructional safeguard.....:		N/A
B.3.3	DC mains polarity test	Not connected to D.C. mains.	N/A
B.3.4	Setting of voltage selector	No voltage select switch.	N/A

IEC 62368-1			
Clause	Requirement + Test	Result - Remark	Verdict
B.3.5	Maximum load at output terminals	(See appended table B.3, B.4)	P
B.3.6	Reverse battery polarity	It is not possible for an ordinary person to replaceable batteries.	N/A
B.3.7	Audio amplifier abnormal operating conditions		N/A
B.3.8	Safeguards functional during and after abnormal operating conditions		P
B.4	Simulated single fault conditions		P
B.4.1	General	See below.	P
B.4.2	Temperature controlling device	No such parts.	N/A
B.4.3	Blocked motor test	No such parts.	N/A
B.4.4	Functional insulation	See below.	P
B.4.4.1	Short circuit of clearances for functional insulation	(See appended table B.3, B.4)	P
B.4.4.2	Short circuit of creepage distances for functional insulation	(See appended table B.3, B.4)	P
B.4.4.3	Short circuit of functional insulation on coated printed boards	No such parts.	N/A
B.4.5	Short-circuit and interruption of electrodes in tubes and semiconductors	(See appended table B.3, B.4)	P
B.4.6	Short circuit or disconnection of passive components	(See appended table B.3, B.4)	P
B.4.7	Continuous operation of components		N/A
B.4.8	Compliance during and after single fault conditions	No ignition occurred during and after test, no component's temperature reached to 90 % of the spontaneous ignition temperature.	P
B.4.9	Battery charging and discharging under single fault conditions		N/A
C	UV RADIATION		—
C.1	Protection of materials in equipment from UV radiation		N/A
C.1.2	Requirements	No such radiation.	N/A
C.1.3	Test method		N/A
C.2	UV light conditioning test		N/A
C.2.1	Test apparatus		N/A
C.2.2	Mounting of test samples		N/A
C.2.3	Carbon-arc light-exposure test		N/A
C.2.4	Xenon-arc light-exposure test		N/A
D	TEST GENERATORS		—
D.1	Impulse test generators		N/A

IEC 62368-1			
Clause	Requirement + Test	Result - Remark	Verdict
D.2	Antenna interface test generator		N/A
D.3	Electronic pulse generator		N/A
E	TEST CONDITIONS FOR EQUIPMENT CONTAINING AUDIO AMPLIFIERS		—
E.1	Electrical energy source classification for audio signals		N/A
	Maximum non-clipped output power (W)		—
	Rated load impedance (Ω)		—
	Open-circuit output voltage (V)		—
	Instructional safeguard		—
E.2	Audio amplifier normal operating conditions		N/A
	Audio signal source type		—
	Audio output power (W).....		—
	Audio output voltage (V).....		—
	Rated load impedance (Ω)		—
	Requirements for temperature measurement		N/A
E.3	Audio amplifier abnormal operating conditions		N/A
F	EQUIPMENT MARKINGS, INSTRUCTIONS, AND INSTRUCTIONAL SAFEGUARDS		—
F.1	General		P
	Language	English.	—
F.2	Letter symbols and graphical symbols		N/A
F.2.1	Letter symbols according to IEC60027-1	No such symbols used in instruction or marking plate.	N/A
F.2.2	Graphic symbols according to IEC, ISO or manufacturer specific		N/A
F.3	Equipment markings		P
F.3.1	Equipment marking locations	Marking plate placed on equipment outer surface.	P
F.3.2	Equipment identification markings	See below.	P
F.3.2.1	Manufacturer identification	See copy of marking plate.	P
F.3.2.2	Model identification	See copy of marking plate.	P
F.3.3	Equipment rating markings	See below.	P
F.3.3.1	Equipment with direct connection to mains		P
F.3.3.2	Equipment without direct connection to mains		N/A
F.3.3.3	Nature of the supply voltage	See copy of marking plate.	P
F.3.3.4	Rated voltage	See copy of marking plate.	P
F.3.3.5	Rated frequency	See copy of marking plate.	P
F.3.3.6	Rated current or rated power	See copy of marking plate.	P

IEC 62368-1			
Clause	Requirement + Test	Result - Remark	Verdict
F.3.3.7	Equipment with multiple supply connections	No such parts.	N/A
F.3.4	Voltage setting device	No such parts.	N/A
F.3.5	Terminals and operating devices	No such parts.	N/A
F.3.5.1	Mains appliance outlet and socket-outlet markings:		N/A
F.3.5.2	Switch position identification marking		N/A
F.3.5.3	Replacement fuse identification and rating markings	Evaluated in certified switching power supply.	P
	Instructional safeguards for neutral fuse		N/A
F.3.5.4	Replacement battery identification marking	Cannot replace an incorrect type.	N/A
F.3.5.5	Neutral conductor terminal		N/A
F.3.5.6	Terminal marking location		N/A
F.3.6	Equipment markings related to equipment classification	See below.	P
F.3.6.1	Class I equipment		P
F.3.6.1.1	Protective earthing conductor terminal.....:	Appliance inlet used.	P
F.3.6.1.2	Protective bonding conductor terminals		N/A
F.3.6.2	Equipment class marking	Class I equipment.	N/A
F.3.6.3	Functional earthing terminal marking		N/A
F.3.7	Equipment IP rating marking	IPX0	N/A
F.3.8	External power supply output marking	No such parts.	N/A
F.3.9	Durability, legibility and permanence of marking	The marking on equipment is durability, legibility and easy to be identified by ordinary person.	P
F.3.10	Test for permanence of markings	The marking plate was subjected to the permanence of marking test. The marking plate was rubbed with cloth soaked with water for 15 s and then again for 15 s with the cloth soaked with petroleum spirit. After each test, there was no damage to the marking plate. The marking on the label did not fade. There was no curling of the marking plate and removed by hand.	P
F.4	Instructions		P
	a) Information prior to installation and initial use	Compliance.	P
	b) Equipment for use in locations where children not likely to be present		N/A

IEC 62368-1			
Clause	Requirement + Test	Result - Remark	Verdict
	c) Instructions for installation and interconnection	Compliance.	P
	d) Equipment intended for use only in restricted access area		N/A
	e) Equipment intended to be fastened in place		N/A
	f) Instructions for audio equipment terminals		N/A
	g) Protective earthing used as a safeguard		N/A
	h) Protective conductor current exceeding ES2 limits		N/A
	i) Graphic symbols used on equipment		N/A
	j) Permanently connected equipment not provided with all-pole mains switch		N/A
	k) Replaceable components or modules providing safeguard function		N/A
	l) Equipment containing insulating liquid		N/A
	m) Installation instructions for outdoor equipment		N/A
F.5	Instructional safeguards		P
G	COMPONENTS		—
G.1	Switches		N/A
G.1.1	General	Not located in PS3 circuits. (See appended table 6.2)	N/A
G.1.2	Ratings, endurance, spacing, maximum load		N/A
G.1.3	Test method and compliance		N/A
G.2	Relays		N/A
G.2.1	Requirements	No such parts.	N/A
G.2.2	Overload test		N/A
G.2.3	Relay controlling connectors supplying power to other equipment		N/A
G.2.4	Test method and compliance		N/A
G.3	Protective devices		P
G.3.1	Thermal cut-offs	No such parts.	N/A
	Thermal cut-outs separately approved according to IEC 60730 with conditions indicated in a) & b)		N/A
	Thermal cut-outs tested as part of the equipment as indicated in c)		N/A
G.3.1.2	Test method and compliance		N/A
G.3.2	Thermal links	No such parts.	N/A
G.3.2.1	a) Thermal links tested separately according to IEC 60691 with specifics		N/A
	b) Thermal links tested as part of the equipment		N/A

IEC 62368-1			
Clause	Requirement + Test	Result - Remark	Verdict
G.3.2.2	Test method and compliance		N/A
G.3.3	PTC thermistors	Certified component used. (See appended table 4.1.2)	P
G.3.4	Overcurrent protection devices	Evaluated in approved SPS.	P
G.3.5	Safeguards components not mentioned in G.3.1 to G.3.4		N/A
G.3.5.1	Non-resettable devices suitably rated and marking provided		N/A
G.3.5.2	Single faults conditions.....:		N/A
G.4	Connectors		N/A
G.4.1	Spacings		N/A
G.4.2	Mains connector configuration		N/A
G.4.3	Plug is shaped that insertion into mains socket-outlets or appliance coupler is unlikely		N/A
G.5	Wound components		P
G.5.1	Wire insulation in wound components	Evaluated in approved SPS.	P
G.5.1.2	Protection against mechanical stress	Evaluated in approved SPS.	P
G.5.2	Endurance test		N/A
G.5.2.1	General test requirements		N/A
G.5.2.2	Heat run test		N/A
	Test time (days per cycle)		—
	Test temperature (°C)		—
G.5.2.3	Wound components supplied from the mains		N/A
G.5.2.4	No insulation breakdown		N/A
G.5.3	Transformers	Evaluated in certified switching power supply.	P
G.5.3.1	Compliance method		N/A
	Position.....:		N/A
	Method of protection.....:		N/A
G.5.3.2	Insulation		N/A
	Protection from displacement of windings		—
G.5.3.3	Transformer overload tests		N/A
G.5.3.3.1	Test conditions		N/A
G.5.3.3.2	Winding temperatures		N/A
G.5.3.3.3	Winding temperatures – alternative test method		N/A
G.5.3.4	Transformers using FIW		N/A
G.5.3.4.1	General		N/A

IEC 62368-1			
Clause	Requirement + Test	Result - Remark	Verdict
	FIW wire nominal diameter		—
G.5.3.4.2	Transformers with basic insulation only		N/A
G.5.3.4.3	Transformers with double insulation or reinforced insulation		N/A
G.5.3.4.4	Transformers with FIW wound on metal or ferrite core		N/A
G.5.3.4.5	Thermal cycling test and compliance		N/A
G.5.3.4.6	Partial discharge test		N/A
G.5.3.4.7	Routine test		N/A
G.5.4	Motors	No such parts.	N/A
G.5.4.1	General requirements		N/A
G.5.4.2	Motor overload test conditions		N/A
G.5.4.3	Running overload test		N/A
G.5.4.4.2	Locked-rotor overload test		N/A
	Test duration (days)		—
G.5.4.5	Running overload test for DC motors		N/A
G.5.4.5.2	Tested in the unit		N/A
G.5.4.5.3	Alternative method		N/A
G.5.4.6	Locked-rotor overload test for DC motors		N/A
G.5.4.6.2	Tested in the unit		N/A
	Maximum Temperature		N/A
G.5.4.6.3	Alternative method		N/A
G.5.4.7	Motors with capacitors		N/A
G.5.4.8	Three-phase motors		N/A
G.5.4.9	Series motors		N/A
	Operating voltage		—
G.6	Wire Insulation		N/A
G.6.1	General	No such parts.	N/A
G.6.2	Enamelled winding wire insulation		N/A
G.7	Mains supply cords		N/A
G.7.1	General requirements	No such parts.	N/A
	Type.....		—
G.7.2	Cross sectional area (mm ² or AWG)		N/A
G.7.3	Cord anchorages and strain relief for non-detachable power supply cords		N/A
G.7.3.2	Cord strain relief		N/A
G.7.3.2.1	Requirements		N/A

IEC 62368-1			
Clause	Requirement + Test	Result - Remark	Verdict
	Strain relief test force (N)		N/A
G.7.3.2.2	Strain relief mechanism failure		N/A
G.7.3.2.3	Cord sheath or jacket position, distance (mm).....		N/A
G.7.3.2.4	Strain relief and cord anchorage material		N/A
G.7.4	Cord Entry		N/A
G.7.5	Non-detachable cord bend protection		N/A
G.7.5.1	Requirements		N/A
G.7.5.2	Test method and compliance		N/A
	Overall diameter or minor overall dimension, <i>D</i> (mm)		—
	Radius of curvature after test (mm).....		—
G.7.6	Supply wiring space		N/A
G.7.6.1	General requirements		N/A
G.7.6.2	Stranded wire		N/A
G.7.6.2.1	Requirements		N/A
G.7.6.2.2	Test with 8 mm strand		N/A
G.8	Varistors		P
G.8.1	General requirements	Evaluated in certified switching power supply.	P
G.8.2	Safeguards against fire		N/A
G.8.2.1	General		N/A
G.8.2.2	Varistor overload test		N/A
G.8.2.3	Temporary overvoltage test		N/A
G.9	Integrated circuit (IC) current limiters		N/A
G.9.1	Requirements	No such parts.	N/A
	IC limiter output current (max. 5A)		—
	Manufacturers' defined drift		—
G.9.2	Test Program		N/A
G.9.3	Compliance		N/A
G.10	Resistors		N/A
G.10.1	General	No such parts.	N/A
G.10.2	Conditioning		N/A
G.10.3	Resistor test		N/A
G.10.4	Voltage surge test		N/A
G.10.5	Impulse test		N/A
G.10.6	Overload test		N/A

IEC 62368-1			
Clause	Requirement + Test	Result - Remark	Verdict
G.11	Capacitors and RC units		P
G.11.1	General requirements	Evaluated in certified switching power supply.	P
G.11.2	Conditioning of capacitors and RC units		N/A
G.11.3	Rules for selecting capacitors		N/A
G.12	Optocouplers		P
	Optocouplers comply with IEC 60747-5-5 with specifics	Evaluated in certified switching power supply.	P
	Type test voltage $V_{ini,a}$		—
	Routine test voltage, $V_{ini,b}$		—
G.13	Printed boards		P
G.13.1	General requirements	See below.	P
G.13.2	Uncoated printed boards	The insulation between conductors on the outer surfaces of an uncoated printed board complied with the minimum clearance and creepage requirements	P
G.13.3	Coated printed boards		N/A
G.13.4	Insulation between conductors on the same inner surface		N/A
G.13.5	Insulation between conductors on different surfaces		N/A
	Distance through insulation		N/A
	Number of insulation layers (pcs)		—
G.13.6	Tests on coated printed boards		N/A
G.13.6.1	Sample preparation and preliminary inspection		N/A
G.13.6.2	Test method and compliance		N/A
G.14	Coating on components terminals		N/A
G.14.1	Requirements	No such parts.	N/A
G.15	Pressurized liquid filled components		N/A
G.15.1	Requirements	No such parts.	N/A
G.15.2	Test methods and compliance		N/A
G.15.2.1	Hydrostatic pressure test		N/A
G.15.2.2	Creep resistance test		N/A
G.15.2.3	Tubing and fittings compatibility test		N/A
G.15.2.4	Vibration test		N/A
G.15.2.5	Thermal cycling test		N/A
G.15.2.6	Force test		N/A

IEC 62368-1			
Clause	Requirement + Test	Result - Remark	Verdict
G.15.3	Compliance		N/A
G.16	IC including capacitor discharge function (ICX)		N/A
G.16.1	Condition for fault tested is not required	No such parts.	N/A
	ICX with associated circuitry tested in equipment		N/A
	ICX tested separately		N/A
G.16.2	Tests		N/A
	Smallest capacitance and smallest resistance specified by ICX manufacturer for impulse test		—
	Mains voltage that impulses to be superimposed on		—
	Largest capacitance and smallest resistance for ICX tested by itself for 10000 cycles test		—
G.16.3	Capacitor discharge test		N/A
H	CRITERIA FOR TELEPHONE RINGING SIGNALS		—
H.1	General		N/A
H.2	Method A		N/A
H.3	Method B		N/A
H.3.1	Ringling signal	No such parts.	N/A
H.3.1.1	Frequency (Hz)		—
H.3.1.2	Voltage (V)		—
H.3.1.3	Cadence; time (s) and voltage (V)		—
H.3.1.4	Single fault current (Ma):		—
H.3.2	Tripping device and monitoring voltage		N/A
H.3.2.1	Conditions for use of a tripping device or a monitoring voltage		N/A
H.3.2.2	Tripping device		N/A
H.3.2.3	Monitoring voltage (V)		N/A
J	INSULATED WINDING WIRES FOR USE WITHOUT INTERLEAVED INSULATION		—
J.1	General		N/A
	Winding wire insulation.....	No such parts.	—
	Solid round winding wire, diameter (mm).....		N/A
	Solid square and rectangular (flatwise bending) winding wire, cross-sectional area (mm ²)		N/A
J.2/J.3	Tests and Manufacturing		—
K	SAFETY INTERLOCKS		—
K.1	General requirements		N/A

IEC 62368-1			
Clause	Requirement + Test	Result - Remark	Verdict
	Instructional safeguard	No such parts.	N/A
K.2	Components of safety interlock safeguard mechanism		N/A
K.3	Inadvertent change of operating mode		N/A
K.4	Interlock safeguard override		N/A
K.5	Fail-safe		N/A
K.5.1	Under single fault condition		N/A
K.6	Mechanically operated safety interlocks		N/A
K.6.1	Endurance requirement		N/A
K.6.2	Test method and compliance		N/A
K.7	Interlock circuit isolation		N/A
K.7.1	Separation distance for contact gaps & interlock circuit elements		N/A
	In circuit connected to mains, separation distance for contact gaps (mm)		N/A
	In circuit isolated from mains, separation distance for contact gaps (mm)		N/A
	Electric strength test before and after the test of K.7.2		N/A
K.7.2	Overload test, Current (A)		N/A
K.7.3	Endurance test		N/A
K.7.4	Electric strength test		N/A
L	DISCONNECT DEVICES		—
L.1	General requirements	The appliance coupler is considered as disconnect device.	P
L.2	Permanently connected equipment		N/A
L.3	Parts that remain energized	When the equipment is disconnected from mains, no remaining parts at hazardous voltage in the equipment.	P
L.4	Single-phase equipment	The disconnect device disconnects both poles simultaneously.	P
L.5	Three-phase equipment		N/A
L.6	Switches as disconnect devices		N/A
L.7	Plugs as disconnect devices	The appliance coupler is considered as disconnect device.	N/A
L.8	Multiple power sources		N/A
	Instructional safeguard		N/A

IEC 62368-1			
Clause	Requirement + Test	Result - Remark	Verdict
M	EQUIPMENT CONTAINING BATTERIES AND THEIR PROTECTION CIRCUITS		—
M.1	General requirements		P
M.2	Safety of batteries and their cells		P
M.2.1	Batteries and their cells comply with relevant IEC standards.....:	See appended table 4.1.2 for RTC coin battery.	P
M.3	Protection circuits for batteries provided within the equipment		P
M.3.1	Requirements		P
M.3.2	Test method	RTC coin battery is protected against charging current by multiple components.	P
	Overcharging of a rechargeable battery		N/A
	Excessive discharging		N/A
	Unintentional charging of a non-rechargeable battery		P
	Reverse charging of a rechargeable battery		N/A
M.3.3	Compliance	(See appended table annex M)	P
M.4	Additional safeguards for equipment containing a portable secondary lithium battery		N/A
M.4.1	General		N/A
M.4.2	Charging safeguards		N/A
M.4.2.1	Requirements		N/A
M.4.2.2	Compliance		N/A
M.4.3	Fire enclosure.....:		N/A
M.4.4	Drop test of equipment containing a secondary lithium battery		N/A
M.4.4.2	Preparation and procedure for the drop test		N/A
M.4.4.3	Drop, Voltage on reference and dropped batteries (V); voltage difference during 24 h period (%):		N/A
M.4.4.4	Check of the charge/discharge function		N/A
M.4.4.5	Charge / discharge cycle test		N/A
M.4.4.6	Compliance		N/A
M.5	Risk of burn due to short-circuit during carrying		N/A
M.5.1	Requirement		N/A
M.5.2	Test method and compliance		N/A
M.6	Safeguards against short-circuits		N/A
M.6.1	External and internal faults		N/A
M.6.2	Compliance		N/A

IEC 62368-1			
Clause	Requirement + Test	Result - Remark	Verdict
M.7	Risk of explosion from lead acid and NiCd batteries		N/A
M.7.1	Ventilation preventing explosive gas concentration		N/A
	Calculated hydrogen generation rate		N/A
M.7.2	Test method and compliance		N/A
	Minimum air flow rate, Q (m ³ /h).....		N/A
M.7.3	Ventilation tests		N/A
M.7.3.1	General		N/A
M.7.3.2	Ventilation test – alternative 1		N/A
	Hydrogen gas concentration (%).....		N/A
M.7.3.3	Ventilation test – alternative 2		N/A
	Obtained hydrogen generation rate		N/A
M.7.3.4	Ventilation test – alternative 3		N/A
	Hydrogen gas concentration (%).....		N/A
M.7.4	Marking.....		N/A
M.8	Protection against internal ignition from external spark sources of batteries with aqueous electrolyte		N/A
M.8.1	General		N/A
M.8.2	Test method		N/A
M.8.2.1	General		N/A
M.8.2.2	Estimation of hypothetical volume V_z (m ³ /s)		—
M.8.2.3	Correction factors		—
M.8.2.4	Calculation of distance d (mm)		—
M.9	Preventing electrolyte spillage		N/A
M.9.1	Protection from electrolyte spillage		N/A
M.9.2	Tray for preventing electrolyte spillage		N/A
M.10	Instructions to prevent reasonably foreseeable misuse	See below.	P
	Instructional safeguard	Battery safety information provided in the user manual.	P
N	ELECTROCHEMICAL POTENTIALS		—
	Material(s) used.....	—	—
O	MEASUREMENT OF CREEPAGE DISTANCES AND CLEARANCES		—
	Value of X (mm)	—	—
P	SAFEGUARDS AGAINST CONDUCTIVE OBJECTS		—
P.1	General	See below.	P
P.2	Safeguards against entry or consequences of entry of a foreign object		P

IEC 62368-1			
Clause	Requirement + Test	Result - Remark	Verdict
P.2.1	General	See below.	P
P.2.2	Safeguards against entry of a foreign object		P
	Location and Dimensions (mm)	No openings.	—
P.2.3	Safeguards against the consequences of entry of a foreign object	See P.2.2	N/A
P.2.3.1	Safeguard requirements		N/A
	The ES3 and PS3 keep-out volume in Figure P.3 not applicable to transportable equipment		N/A
	Transportable equipment with metalized plastic parts.....		N/A
P.2.3.2	Consequence of entry test		N/A
P.3	Safeguards against spillage of internal liquids		N/A
P.3.1	General		N/A
P.3.2	Determination of spillage consequences		N/A
P.3.3	Spillage safeguards		N/A
P.3.4	Compliance		N/A
P.4	Metallized coatings and adhesives securing parts		N/A
P.4.1	General		N/A
P.4.2	Tests		N/A
	Conditioning, T _c (°C)		—
	Duration (weeks)		—
Q	CIRCUITS INTENDED FOR INTERCONNECTION WITH BUILDING WIRING		—
Q.1	Limited power sources	See below.	P
Q.1.1	Requirements		P
	a) Inherently limited output	RJ45 port (LAN219_J1, LAN225_J1)	P
	b) Impedance limited output	USB 3.0 port (USB3_HR1); USB 3.2 port (USB3_J3); USB 2.0 port (USB2_J1); Display port (DP_J1, DP_J2)	P
	c) Regulating network limited output		N/A
	d) Overcurrent protective device limited output		N/A
	e) IC current limiter complying with G.9		N/A
Q.1.2	Test method and compliance		P
	Current rating of overcurrent protective device (A)		N/A
Q.2	Test for external circuits – paired conductor cable		N/A
	Maximum output current (A)		N/A

IEC 62368-1			
Clause	Requirement + Test	Result - Remark	Verdict
	Current limiting method		—
R	LIMITED SHORT CIRCUIT TEST		—
R.1	General	No such parts.	N/A
R.2	Test setup		N/A
	Overcurrent protective device for test		—
R.3	Test method		N/A
	Cord/cable used for test		—
R.4	Compliance		N/A
S	TESTS FOR RESISTANCE TO HEAT AND FIRE		—
S.1	Flammability test for fire enclosures and fire barrier materials of equipment where the steady state power does not exceed 4 000 W		N/A
	Samples, material.....	No such parts.	—
	Wall thickness (mm)		—
	Conditioning (°C)		—
	Test flame according to IEC 60695-11-5 with conditions as set out		N/A
	- Material not consumed completely		N/A
	- Material extinguishes within 30s		N/A
	- No burning of layer or wrapping tissue		N/A
S.2	Flammability test for fire enclosure and fire barrier integrity		N/A
	Samples, material.....		—
	Wall thickness (mm)		—
	Conditioning (°C)		—
S.3	Flammability test for the bottom of a fire enclosure		N/A
S.3.1	Mounting of samples		N/A
S.3.2	Test method and compliance		N/A
	Mounting of samples		—
	Wall thickness (mm)		—
S.4	Flammability classification of materials		N/A
S.5	Flammability test for fire enclosure materials of equipment with a steady state power exceeding 4 000 W		N/A
	Samples, material.....		—
	Wall thickness (mm)		—
	Conditioning (°C)		—

IEC 62368-1			
Clause	Requirement + Test	Result - Remark	Verdict
T	MECHANICAL STRENGTH TESTS		—
T.1	General		P
T.2	Steady force test, 10 N		N/A
T.3	Steady force test, 30 N		N/A
T.4	Steady force test, 100 N		N/A
T.5	Steady force test, 250 N	(See appended table T.2, T.3, T.4, T.5)	P
T.6	Enclosure impact test	(See appended table T.6, T.9)	P
	Fall test	See above.	P
	Swing test		N/A
T.7	Drop test		N/A
T.8	Stress relief test		N/A
T.9	Glass Impact Test		N/A
T.10	Glass fragmentation test		N/A
	Number of particles counted		N/A
T.11	Test for telescoping or rod antennas		N/A
	Torque value (Nm)		N/A
U	MECHANICAL STRENGTH OF CATHODE RAY TUBES (CRT) AND PROTECTION AGAINST THE EFFECTS OF IMPLOSION		—
U.1	General		N/A
	Instructional safeguard :		N/A
U.2	Test method and compliance for non-intrinsically protected CRTs		N/A
U.3	Protective screen		N/A
V	DETERMINATION OF ACCESSIBLE PARTS		—
V.1	Accessible parts of equipment		P
V.1.1	General	The surfaces and openings are evaluated by the test probe of Figure V.1 and V.2	P
V.1.2	Surfaces and openings tested with jointed test probes	No live parts can be accessible.	P
V.1.3	Openings tested with straight unjointed test probes	No live parts can be accessible.	P
V.1.4	Plugs, jacks, connectors tested with blunt probe		N/A
V.1.5	Slot openings tested with wedge probe		N/A
V.1.6	Terminals tested with rigid test wire		N/A
V.2	Accessible part criterion		P

IEC 62368-1			
Clause	Requirement + Test	Result - Remark	Verdict
X	ALTERNATIVE METHOD FOR DETERMINING CLEARANCES FOR INSULATION IN CIRCUITS CONNECTED TO AN AC MAINS NOT EXCEEDING 420 V PEAK (300 V RMS)		—
	Clearance..... :		N/A
Y	CONSTRUCTION REQUIREMENTS FOR OUTDOOR ENCLOSURES		—
Y.1	General	Not outdoor use.	N/A
Y.2	Resistance to UV radiation		N/A
Y.3	Resistance to corrosion		N/A
Y.3.1	Metallic parts of outdoor enclosures are resistant to effects of water-borne contaminants by		N/A
Y.3.2	Test apparatus		N/A
Y.3.3	Water – saturated sulphur dioxide atmosphere		N/A
Y.3.4	Test procedure..... :		N/A
Y.3.5	Compliance		N/A
Y.4	Gaskets		N/A
Y.4.1	General		N/A
Y.4.2	Gasket tests		N/A
Y.4.3	Tensile strength and elongation tests		N/A
	Alternative test methods..... :		N/A
Y.4.4	Compression test		N/A
Y.4.5	Oil resistance		N/A
Y.4.6	Securing means		N/A
Y.5	Protection of equipment within an outdoor enclosure		N/A
Y.5.1	General		N/A
Y.5.2	Protection from moisture		N/A
	Relevant tests of IEC 60529 or Y.5.3..... :		N/A
Y.5.3	Water spray test		N/A
Y.5.4	Protection from plants and vermin		N/A
Y.5.5	Protection from excessive dust		N/A
Y.5.5.1	General		N/A
Y.5.5.2	IP5X equipment		N/A
Y.5.5.3	IP6X equipment		N/A
Y.6	Mechanical strength of enclosures		N/A
Y.6.1	General		N/A
Y.6.2	Impact test..... :		N/A

IEC 62368-1			
Clause	Requirement + Test	Result - Remark	Verdict

5.2	TABLE: Classification of electrical energy sources						N/A
Supply Voltage	Location (e.g. circuit designation)	Test conditions	Parameters				ES Class
			U (V)	I (mA)	Type ¹⁾	Additional Info ²⁾	

Supplementary information:

1) Type: Steady state (SS), Capacitance (CP), Single pulse (SP), Repetitive pulses (RP), etc.
2) Additional Info: Frequency, Pulse duration, Pulse off time, Capacitance value, etc.

5.4.1.8	TABLE: Working voltage measurement					N/A
Location	RMS voltage (V)	Peak voltage (V)	Frequency (Hz)	Comments		

Supplementary information:

5.4.1.10.2	TABLE: Vicat softening temperature of thermoplastics				N/A
Method.....:			ISO 306 / B50		—
Object/ Part No./Material	Manufacturer/trademark	Thickness (mm)	T softening (°C)		

Supplementary information:

5.4.1.10.3	TABLE: Ball pressure test of thermoplastics				N/A
Allowed impression diameter (mm).....:			≤ 2 mm		—
Object/Part No./Material	Manufacturer/trademark	Thickness (mm)	Test temperature (°C)	Impression diameter (mm)	

Supplementary information:

IEC 62368-1								
Clause	Requirement + Test				Result - Remark			Verdict
5.4.2, 5.4.3	TABLE: Minimum Clearances/Creepage distance							N/A
Clearance (cl) and creepage distance (cr) at/of/between:	U_p (V)	U_{rms} (V)	Freq ¹⁾ (Hz)	Required cl (mm)	cl (mm)	E.S. ²⁾ (V)	Required cr (mm)	cr (mm)
Supplementary information:								
1) Only for frequency above 30 kHz								
2) Complete Electric Strength voltage (E.S. (V) when 5.4.2.4 applied)								

5.4.4.2	TABLE: Minimum distance through insulation					N/A
Distance through insulation (DTI) at/of	Peak voltage (V)		Insulation	Required DTI (mm)	Measured DTI (mm)	
Supplementary information:						
1. ¹⁾ See appended table 4.1.2 for details.						
2. RI: Reinforced insulation; BI: Basic insulation; SI: Supplementary insulation.						
Note 1: Only for frequency above 30 kHz.						

5.4.4.9	TABLE: Solid insulation at frequencies >30 kHz						N/A
Insulation material	E_p	Frequency (kHz)	K_R	Thickness d (mm)	Insulation	V_{PW} (Vpk)	
Supplementary information:							

5.4.9	TABLE: Electric strength tests			P
Test voltage applied between:	Voltage shape (Surge, Impulse, AC, DC, etc.)		Test voltage (V)	Breakdown Yes / No
Basic insulation or supplementary insulation:				
Primary circuit to metal enclosure (PE)	DC		2500	No
Reinforced insulation:				
Primary circuit to secondary circuit (without PE)	DC		4000	No
Supplementary information:				

IEC 62368-1			
Clause	Requirement + Test	Result - Remark	Verdict

5.5.2.2	TABLE: Stored discharge on capacitors					N/A
Location	Supply voltage (V)	Operating and fault condition ¹⁾	Switch position	Measured voltage (V _{pk})	ES Class	
Supplementary information:						
X-capacitors installed for testing:						
[] bleeding resistor rating:						
[] ICX:						
1) N= Normal operating condition (e.g., normal operation, or open fuse), S= Single fault condition, SC= short circuit, OC= open circuit						

5.6.6	TABLE: Resistance of protective conductors and terminations				P
Location	Test current (A)	Duration (min)	Voltage drop (V)	Resistance (Ω)	
Earth pin of AC inlet to metal enclosure	32	2	0.384	0.012	
Earth pin of AC inlet to metal enclosure	40	2	0.520	0.013	
Supplementary information:					

5.7.4	TABLE: Unearthed accessible parts					P
Location	Operating and fault conditions	Supply Voltage (V)	Parameters			ES class
			Voltage (V _{rms} or V _{pk})	Current (A _{rms} or A _{pk})	Freq. (Hz)	
Primary circuit to control button	Normal	264	--	0.01 mA _{pk}	--	ES1
	Abnormal (See table B.3, B.4)	264	--	0.01 mA _{pk}	--	ES1
	Single fault-SC/OC (See table B.3, B.4)	264	--	0.01 mA _{pk}	--	ES1
Primary circuit to secondary circuit (without PE)	Normal	264	--	0.01 mA _{pk}	--	ES1
	Abnormal (See table B.3, B.4)	264	--	0.01 mA _{pk}	--	ES1
	Single fault-SC/OC (See table B.3, B.4)	264	--	0.01 mA _{pk}	--	ES1
Supplementary information:						
Abbreviation: SC= short circuit; OC= open circuit						

IEC 62368-1			
Clause	Requirement + Test	Result - Remark	Verdict

5.7.5	TABLE: Earthed accessible conductive part			P
Supply voltage (V).....:	AC 264			—
Phase(s)	[X] Single Phase; [] Three Phase: [] Delta [] Wye			
Power Distribution System	[X] TN [] TT [] IT			
Location	Fault Condition No in IEC 60990 clause 6.2.2	Touch current (mA)	Comment	
Metal enclosure	1	Max. 0.229 mA _{pk}	normal/reverse	
Supplementary Information:				

5.8	TABLE: Backfeed safeguard in battery backed up supplies					N/A
Location	Supply voltage (V)	Operating and fault condition	Time (s)	Open-circuit voltage (V)	Touch current (A)	ES Class
Supplementary information:						
Abbreviation: SC= short circuit, OC= open circuit						

6.2.2	TABLE: Power source circuit classifications					P
Location	Operating and fault condition	Voltage (V)	Current (A)	Max. Power ¹⁾ (W)	Time (S)	PS class
FIO_PANEL1 (6 – 8) (Power Switch)	Normal	3.17	0	0	--	PS1
FIO_PANEL1 (6 – 8) (Power Switch)	R550 SC	3.19	0	0	--	PS1
Supplementary information:						
Abbreviation: SC= short circuit; OC= open circuit						
1) Measured after 3 s for PS1 and measured after 5 s for PS2 and PS3.						

IEC 62368-1				
Clause	Requirement + Test	Result - Remark	Verdict	
6.2.3.1	TABLE: Determination of Arcing PIS			P
Location	Open circuit voltage after 3 s (Vpk)	Measured r.m.s current (A)	Calculated value	Arcing PIS? Yes / No
Supplementary information:				

6.2.3.2	TABLE: Determination of resistive PIS			P
Location	Operating and fault condition	Dissipate power (W)	Arcing PIS? Yes / No	
Supplementary information:				
Abbreviation: SC= short circuit; OC= open circuit				
1) All circuits within the EUT are considered as resistive PIS.				

8.5.5	TABLE: High pressure lamp				N/A
Lamp manufacturer	Lamp type	Explosion method	Longest axis of glass particle (mm)	Particle found beyond 1 m Yes / No	
Supplementary information:					

9.6	TABLE: Temperature measurements for wireless power transmitters							N/A
Supply voltage (V)..... :							—	
Max. transmit power of transmitter (W)..... :							—	
Foreign objects	w/o receiver and direct contact		with receiver and direct contact		with receiver and at distance of 2 mm		with receiver and at distance of 5 mm	
	Object (°C)	Ambient (°C)	Object (°C)	Ambient (°C)	Object (°C)	Ambient (°C)	Object (°C)	Ambient (°C)
Supplementary information:								

IEC 62368-1				
Clause	Requirement + Test	Result - Remark		Verdict
5.4.1.4, 9.3, B.1.5, B.2.6	TABLE: Temperature measurements			P
Supply voltage (V)	See below		—	
Ambient temperature during test T_{amb} (°C)	See below		—	
Maximum measured temperature T of part/at:	T (°C)		Allowed T_{max} (°C)	
Supply voltage (V)	99 V/ 60 Hz	264 V/ 60 Hz		--
Ambient temperature during test T_{amb} (°C) :	22.4	22.7		--
Below values for T (°C) are re-calculated to 60 °C from actual ambient respectively:				
AC inlet near L pin	79.0	78.5		120
AC wire near L pin	83.4	83.1		105
SPS: LF1 coil	97.3	96.9		130
SPS: C1	96.2	95.9		100
SPS: LF2 coil	96.6	96.2		130
SPS: L1 coil	97.8	97.4		130
SPS: L2 coil	97.7	97.3		130
SPS: C5	95.5	95.1		105
SPS: T1 coil	98.5	98.2		110
SPS: PCB near Q1	100.1	99.8		130
Main board: PCB near CPU	115.6	115.6		130
Main board: PCB near TP119	112.7	112.8		130
Main board: RTC body	95.8	95.8		100
Main board: PCB near U21	113.6	113.6		130
Riser board: PCB near U1	88.7	88.3		130
SSD body	97.7	97.4		--
Accessible part: (re-calculated to 25 degree C from actual ambient respectively)				
Metal enclosure outside near SPS	43.2	42.9		⁴⁾ 60 (TS1)
Metal enclosure outside near top side	51.0	51.0		⁴⁾ 60 (TS1)
Annex B.3 - Simulated abnormal operating conditions test				
Test condition:	USB 3.0 port overload	USB 3.2 port overload	USB 2.0 port overload	--
Supply voltage (V)	264 V/ 60 Hz	264 V/ 60 Hz	264 V/ 60 Hz	--
Ambient temperature during test T_{amb} (°C) :	23.0	22.8	23.0	--
Below values for T (°C) are re-calculated to 60 °C from actual ambient respectively:				
AC inlet near L pin	78.2	78.1	78.1	300
AC wire near L pin	81.8	81.6	81.5	300

IEC 62368-1							
Clause	Requirement + Test			Result - Remark			Verdict
SPS: LF1 coil	91.7			91.3		91.1	300
SPS: C1	93.9			93.4		93.2	300
SPS: LF2 coil	93.1			92.6		92.5	300
SPS: L1 coil	94.7			94.2		94.1	300
SPS: L2 coil	93.2			92.7		92.6	300
SPS: C5	93.5			93.0		93.0	300
SPS: T1 coil	97.6			96.8		96.8	175
SPS: PCB near Q1	96.5			95.9		95.9	300
Main board: PCB near CPU	117.3			116.0		116.0	300
Main board: PCB near TP119	114.9			113.4		112.9	300
Main board: RTC body	96.8			96.2		96.9	300
Main board: PCB near U21	116.2			114.3		114.0	300
Riser board: PCB near U1	88.6			88.3		88.3	300
SSD body	97.5			97.0		96.9	300
Accessible part: (re-calculated to 25 degree C from actual ambient respectively)							
Metal enclosure outside near SPS		42.6		42.4		42.5	4) 70 (TS2)
Metal enclosure outside near top side		51.2		50.8		50.9	4) 70 (TS2)
Temperature T of winding:	t ₁ (°C)	R ₁ (Ω)	t ₂ (°C)	R ₂ (Ω)	T (°C)	Allowed T _{max} (°C)	Insulation class
--							
Supplementary information:							
1) The temperatures were measured under worst case normal mode and at voltages as described above.							
2) With a maximum ambient temperature of +60 °C as declared by the manufacturer.							
3) All values for T (°C) are re-calculated from actual ambient.							
4) Surfaces touched considered as > 1 s and < 10 s.							

IEC 62368-1								
Clause	Requirement + Test				Result - Remark			Verdict
B.2.5	TABLE: Input test							P
U (V)	Hz	I (A)	I rated (A)	P (W)	P rated (W)	Fuse No	I fuse (A)	Condition/status
99	50	0.92	--	89.1	--	In SPS	0.92	Maximum normal load
99	60	0.92	--	89.0	--	In SPS	0.92	Maximum normal load
110	50	0.83	2.6	88.9	--	In SPS	0.83	Maximum normal load
110	60	0.83	2.6	89.1	--	In SPS	0.83	Maximum normal load
240	50	0.42	2.6	88.5	--	In SPS	0.42	Maximum normal load
240	60	0.42	2.6	88.5	--	In SPS	0.42	Maximum normal load
264	50	0.38	--	87.5	--	In SPS	0.38	Maximum normal load
264	60	0.39	--	87.8	--	In SPS	0.39	Maximum normal load
Supplementary information:								
Equipment may be have rated current or rated power or both. Both should be measured.								

IEC 62368-1						
Clause	Requirement + Test				Result - Remark	Verdict
B.3, B.4	TABLE: Abnormal operating and fault condition tests					P
Ambient temperature T_{amb} (°C)					25 °C if not mentioned	—
Power source for EUT: Manufacturer, model/type, outputrating ..					See appended table 4.1.2	—
Component No.	Condition	Supply voltage (V)	Test time	Fuse no.	Fuse current (A)	Observation
USB 3.0 port	Overload	264 Vac / 60 Hz	7 hr 58 mins	In SPS	0.39 → 0.40	Max voltage 5.07 V, output current 1.9 A normal operating, output current 2.1 A, USB 3.0 port output shut down, other normal operation, no fire or flame hazards occurred during and after the test. Temperature results refer to Table 5.4.1.4, 9.3, B.1.5, B.2.6
USB 3.2 port	Overload	264 Vac / 60 Hz	7 hr 8 mins	In SPS	0.39 → 0.40	Max voltage 5.12 V, output current 1.9 A normal operating, output current 2.1 A, USB 3.2 port output shut down, other normal operation, no fire or flame hazards occurred during and after the test. Temperature results refer to Table 5.4.1.4, 9.3, B.1.5, B.2.6
USB 2.0 port	Overload	264 Vac / 60 Hz	7 hr 8 mins	In SPS	1.18 → 1.20 → 1.17	Max voltage 5.12 V, output current 1.0 A normal operating, output current 1.2 A, USB 2.0 port output shut down, other normal operation, no fire or flame hazards occurred during and after the test. Temperature results refer to Table 5.4.1.4, 9.3, B.1.5, B.2.6
Q22 (1 – 4)	Short circuit	264 Vac / 60 Hz	10 mins	In SPS	0.05	EUT shut down, no fire or flame hazards occurred during and after the test.
Supplementary information:						

IEC 62368-1

Clause	Requirement + Test	Result - Remark	Verdict
--------	--------------------	-----------------	---------

M.3	TABLE: Protection circuits for batteries provided within the equipment		P
------------	---	--	---

Is it possible to install the battery in a reverse polarity position?.....:	No	---
---	----	-----

Equipment Specification	Charging	
	Voltage (V)	Current (A)
	--	--

Manufacturer/type	Battery specification					
	Non-rechargeable batteries		Rechargeable batteries			
	Discharging current (A)	Unintentional charging current (A)	Charging		Discharging current (A)	Reverse charging current (A)
			Voltage (V)	Current (A)		
See appended table 4.1.2 / CR2032 series	--	10 mA	--	--	--	--

Note: The tests of M.3.2 are applicable only when above appropriate data is not available.

Specified battery temperature (°C)	--
--	----

Component No.	Fault condition	Charge/discharge mode	Test time	Temp. (°C)	Current (A)	Voltage (V)	Observation
XBT1	Normal	Charge	--	--	0	--	NL, NS, NE, NF
XBT1	R556 SC	Charge	--	--	0	--	NL, NS, NE, NF
XBT1	D25 (2 – 3) SC	Charge	--	--	3 mA	--	NL, NS, NE, NF

Supplementary information:

Abbreviation: SC= short circuit; OC= open circuit NL= no chemical leakage; NS= no spillage of liquid; NE= no explosion; NF= no emission of flame or expulsion of molten metal.

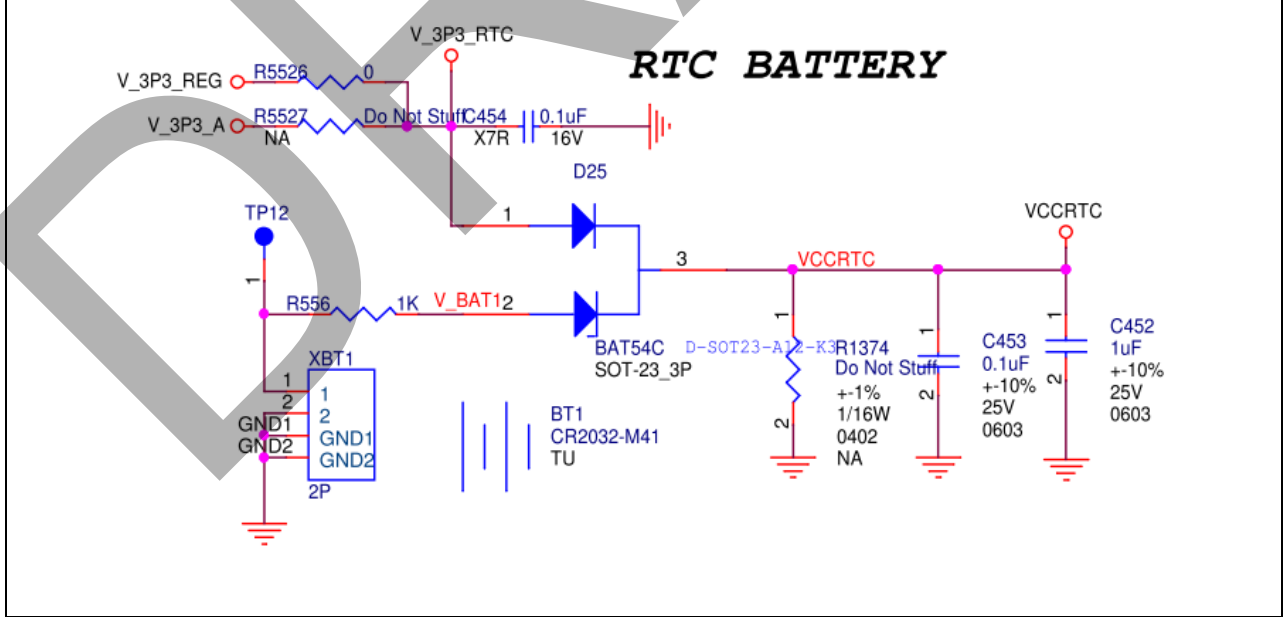

IEC 62368-1					
Clause	Requirement + Test	Result - Remark	Verdict		
M.4.2	TABLE: Charging safeguards for equipment containing a secondary lithium battery		N/A		
Maximum specified charging voltage (V)			—		
Maximum specified charging current (A)			—		
Highest specified charging temperature (°C)					
Lowest specified charging temperature (°C)					
Battery manufacturer/type	Operating and fault condition	Measurement			Observation
		Charging voltage (V)	Charging current (A)	Temp. (°C)	
Supplementary information:					
Abbreviation: SC= short circuit; OC= open circuit; MSCV= maximum specified charging voltage; MSCC= maximum specified charging current; HSCT= highest specified charging temperature; LSCT= lowest specified charging temperature					

Q.1	TABLE: Circuits intended for interconnection with building wiring (LPS)						P
Output Circuit	Condition	U _{oc} (V)	Time (s)	I _{sc} (A)		S (VA)	
				Meas.	Limit	Meas.	Limit
USB 3.0 port (USB3_HR 1), Pin 1 to GND. (Protection by F21)	Normal condition	5.07	5	3.23	≤8	11.45	≤100
USB 3.0 port (USB3_HR 1), Pin 19 to GND. (Protection by F21)	Normal condition	5.07	5	3.26	≤8	11.51	≤100
USB 3.0 port (USB3_HR 1), other pins to GND.	Normal condition	0	--	0	≤8	0	≤100
DP port (DP_J2), Pin 17 to GND.	Normal condition	2.78	--	0	≤8	0	≤100

IEC 62368-1							
Clause	Requirement + Test	Result - Remark					Verdict
DP port (DP_J2), Pin 20 to GND. (Protection by F24)	Normal condition	3.3	5	2.07	≤8	2.90	≤100
DP port (DP_J2), other pins to GND.	Normal condition	0	--	0	≤8	0	≤100
DP port (DP_J1), Pin 17 to GND.	Normal condition	2.77	--	0	≤8	0	≤100
DP port (DP_J1), Pin 20 to GND. (Protection by F1)	Normal condition	3.3	5	2.10	≤8	2.82	≤100
DP port (DP_J1), other pins to GND.	Normal condition	0	--	0	≤8	0	≤100
USB 2.0 port (USB2_J1), Pin 1 to GND. (Protection by F6)	Normal condition	5.12	5	1.84	≤8	7.61	≤100
USB 2.0 port (USB2_J1), Pin 5 to GND. (Protection by F6)	Normal condition	5.12	5	1.80	≤8	7.45	≤100
USB 2.0 port (USB2_J1), other pins to GND.	Normal condition	0	--	0	≤8	0	≤100
RJ45 port (LAN225_J1), all pins to GND.	Normal condition	0	--	0	≤8	0	≤100

IEC 62368-1							
Clause	Requirement + Test	Result - Remark					Verdict
RJ45 port (LAN219_J1), all pins to GND.	Normal condition	0	--	0	≤8	0	≤100
USB 3.2 port (USB3_J3), Pin 1 to GND. (Protection by F5)	Normal condition	5.12	5	3.65	≤8	13.90	≤100
USB 3.2 port (USB3_J3), Pin 10 to GND. (Protection by F5)	Normal condition	5.12	5	3.59	≤8	13.70	≤100
USB 3.2 port (USB3_J3), other pins to GND.	Normal condition	0	--	0	≤8	0	≤100
Supplementary Information:							

T.2, T.3, T.4, T.5	TABLE: Steady force test						P
Location/Part	Material	Thickness (mm)	Probe	Force (N)	Test Duration (s)	Observation	
Enclosure/ Top	See appended table 4.1.2	See appended table 4.1.2	--	250	5	1)	
Enclosure/ Side	See appended table 4.1.2	See appended table 4.1.2	--	250	5	1)	
Enclosure/ Rear	See appended table 4.1.2	See appended table 4.1.2	--	250	5	1)	
Supplementary information:							
No cracking, ES3 did not become accessible and all safeguards remain effective. No indication of dielectric breakdown.							

IEC 62368-1					
Clause	Requirement + Test			Result - Remark	Verdict
T.6, T.9	TABLE: Impact test				P
Location/Part	Material	Thickness (mm)	Height (mm)	Observation	
Enclosure/ Top	See appended table 4.1.2	See appended table 4.1.2	1300	1)	
Enclosure/ Side	See appended table 4.1.2	See appended table 4.1.2	1300	1)	
Enclosure/ Rear	See appended table 4.1.2	See appended table 4.1.2	1300	1)	
Supplementary information:					
1) No cracking, ES3 did not become accessible and all safeguards remain effective. No indication of dielectric breakdown.					

T.7	TABLE: Drop test				N/A
Location/Part	Material	Thickness (mm)	Height (mm)	Observation	
Supplementary information:					

T.8	TABLE: Stress relief test					N/A
Location/Part	Material	Thickness (mm)	Oven Temperature (°C)	Duration (h)	Observation	
Supplementary information:						

X	TABLE: Alternative method for determining minimum clearances distances			N/A
Clearance distanced between:	Peak of working voltage (V)	Required cl (mm)	Measured cl (mm)	
Supplementary information:				

IEC 62368-1					
Clause	Requirement + Test		Result - Remark		Verdict
4.1.2	TABLE: Critical components information				P
Object / part No.	Manufacturer/ trademark	Type / model	Technical data	Standard	Mark(s) of conformity ¹⁾
Enclosure material	--	--	Zn on steel; minimum 1.0 mm thickness.	--	--
Appliance Inlet (One provided)	INALWAYS CORP	0716-1 Series	10A, 250V~; C16 type; 120 °C	EN 60320- 1:2015; EN 60320- 3:2014	ENEC (ENEC- 02233)
Switching power supply (SPS) (One provided)	MEAN WELL Enterprises Co., Ltd.	UHP-200-12	I/P: 100-240 V~, 2.6 A, 50/60 Hz; O/P: 12 V d.c., 16.7 A; 50 °C; 5000 m	IEC 62368- 1:2018	CB (JPTUV- 154303)
All PCBs	OLYMPIC COUNTRY CO LTD	OC-168	V-0; 130 °C	UL 796	UL (E122808)
(Alternative)	Interchangeable	Interchangeable	V-1 or better; 130 °C	UL 796	UL*
Solid State Drive (SSD) (Optional)	Interchangeable	Interchangeable	Rated 5 V d.c., maximum 1.5 A	--	--
Poly-switch (F1, F6, F24) (USB 2.0 port and DP port protector)	Bourns Inc.	MF- NSMF150-2	PTC type; Vmax. 6 V d.c.; Ih: 1500 mA; It: 3000 mA	EN 60730- 1:2016+A1:2019 IEC 60730- 1:2013+A1+A2; UL 1434	TÜV (R 50256634); UL (E174545)
(Alternative)	Polytronics Technology Corp.	SMD1206P15 0TFT	PTC type; Vmax. 6 V d.c.; Ih: 1500 mA; It: 3000 mA	EN 60730- 1:2016+A1:2019 IEC 60730- 1:2013+A1+A2; UL 1434	TÜV (R 50099121); UL (E515859)
Poly-switch (F5, F21) (USB 3.2 port and USB 3.0 port protector)	Bourns Inc.	MF- MSMF200-2	PTC type; Vmax. 8 V d.c.; Ih: 2000 mA; It: 4000 mA	EN 60730- 1:2016+A1:2019 IEC 60730- 1:2013+A1+A2; UL 1434	TÜV (R 50256634); UL (E174545)
(Alternative)	Littelfuse Inc.	miniSMDC200 F-2	PTC type; Vmax. 8 V d.c.; Ih: 2000 mA; It: 4000 mA	EN 60730- 1:2016+A1:2019 IEC 60730- 1:2013+A1+A2; UL 1434	TÜV (R 72161779); UL (E74889)

IEC 62368-1					
Clause	Requirement + Test		Result - Remark		Verdict
RTC battery (XBT1)	Tohoku Murata Manufacturing Co., Ltd.	CR2032	3V, 220 mAh; Max. abnormal charging current 10 mA.	IEC 60086-4:2019; UL 1642	CB (DK-121264-UL); UL (MH12566)
(Alternate)	Maxell Ltd.	CR2032	3V, 220 mAh; Max. abnormal charging current 10 mA.	IEC 60086-4:2019; UL 1642	CB (DK-127762-UL); UL (MH12568)
(Alternate)	Maxell Ltd.	CR2032 H	3V, 240 mAh; Max. abnormal charging current 10 mA.	IEC 60086-4:2019; UL 1642	CB (DK-127759-UL); UL (MH12568)
(Alternate)	Panasonic Corporation	CR2032	3V, 225 mAh; Max. abnormal charging current 10 mA.	IEC 60086-4:2019; UL 1642	CB (NL-76305); UL (MH12210)
(Alternate)	SHUN WO TECHNOLOGY (HUIZHOU) CO., LTD.	CR2032	3V, 230 mAh; Max. abnormal charging current 10 mA.	IEC 60086-4:2019; UL 1642	CB (SG PSB-BT-04487); UL (MH25881)
(Alternate)	Interchangeable	CR2032 series	Max. abnormal charging current 10 mA.	IEC 60086-4:2019; UL 1642	CB; UL*
Supplementary information:					
1) Provided evidence ensures the agreed level of compliance. See OD-2039.					

-- END of TEST REPORT --

IEC62368_1E - ATTACHMENT

Clause	Requirement + Test	Result - Remark	Verdict
--------	--------------------	-----------------	---------

Attachment 1 European Group Differences And National Differences

<p align="center">ATTACHMENT TO TEST REPORT IEC 62368-1 EUROPEAN GROUP DIFFERENCES AND NATIONAL DIFFERENCES (Audio/video, information and communication technology equipment - Part 1: Safety requirements)</p>										
Differences according to	EN IEC 62368-1:2020+A11:2020									
Attachment Form No.	EU_GD_IEC62368_1E									
Attachment Originator.....	UL(Demko)									
Master Attachment	2021-02-04									
<p>Copyright © 2021 IEC System for Conformity Testing and Certification of Electrical Equipment (IECEE), Geneva, Switzerland. All rights reserved.</p>										
	CENELEC COMMON MODIFICATIONS (EN)	—								
	<p>Clause numbers in the cells that are shaded light grey are clause references in EN IEC 62368-1:2020+A11:2020. All other clause numbers in that column, except for those in the paragraph below, refers to IEC 62368-1:2018.</p> <p>Clauses, subclauses, notes, tables, figures and annexes which are additional to those in IEC 62368-1:2018 are prefixed “Z”.</p>	P								
	<p>Add the following annexes:</p> <table border="0"> <tr> <td>Annex ZA (normative)</td> <td>Normative references to international publications with their corresponding European publications</td> </tr> <tr> <td>Annex ZB (normative)</td> <td>Special national conditions</td> </tr> <tr> <td>Annex ZC (informative)</td> <td>A-deviations</td> </tr> <tr> <td>Annex ZD (informative)</td> <td>IEC and CENELEC code designations for flexible cords</td> </tr> </table>	Annex ZA (normative)	Normative references to international publications with their corresponding European publications	Annex ZB (normative)	Special national conditions	Annex ZC (informative)	A-deviations	Annex ZD (informative)	IEC and CENELEC code designations for flexible cords	P
Annex ZA (normative)	Normative references to international publications with their corresponding European publications									
Annex ZB (normative)	Special national conditions									
Annex ZC (informative)	A-deviations									
Annex ZD (informative)	IEC and CENELEC code designations for flexible cords									
1	Modification to Clause 3 .	—								
3.3.19	<p>Sound exposure Replace 3.3.19 of IEC 62368-1 with the following definitions:</p>	N/A								
3.3.19.1	<p>momentary exposure level, MEL metric for estimating 1 s sound exposure level from the HD 483-1 S2 test signal applied to both channels, based on EN 50332-1:2013, 4.2.</p> <p>Note 1 to entry: MEL is measured as A-weighted levels in dB. Note 2 to entry: See B.3 of EN 50332-3:2017 for additional information.</p>	N/A								

IEC62368_1E - ATTACHMENT			
Clause	Requirement + Test	Result - Remark	Verdict
3.3.19.3	<p>sound exposure, E</p> <p>A-weighted sound pressure (p) squared and integrated over a stated period of time, T</p> <p>Note 1 to entry: The SI unit is Pa² s.</p> $E = \int_0^T p(t)^2 dt$		N/A
3.3.19.4	<p>sound exposure level, SEL</p> <p>logarithmic measure of sound exposure relative to a reference value, E_0, typically the 1 kHz threshold of hearing in humans.</p> <p>Note 1 to entry: SEL is measured as A-weighted levels in dB.</p> $SEL = 10 \lg \left(\frac{E}{E_0} \right) \text{ dB}$ <p>Note 2 to entry: See B.4 of EN 50332-3:2017 for additional information.</p>		N/A
3.3.19.5	<p>digital signal level relative to full scale, dBFS</p> <p>levels reported in dBFS are always r.m.s. Full scale level, 0 dBFS, is the level of a dc-free 997-Hz sine wave whose undithered positive peak value is positive digital full scale, leaving the code corresponding to negative digital full scale unused</p> <p>Note 1 to entry: It is invalid to use dBFS for non-r.m.s. levels. Because the definition of full scale is based on a sine wave, the level of signals with a crest factor lower than that of a sine wave may exceed 0 dBFS. In particular, square wave signals may reach +3,01 dBFS.</p>		N/A
2	Modification to Clause 10		—
10.6	<p>Safeguards against acoustic energy sources</p> <p>Replace 10.6 of IEC 62368-1 with the following:</p>		—
10.6.1.1	<p>Introduction</p> <p>Safeguard requirements for protection against long-term exposure to excessive sound pressure levels from personal music players closely coupled to the ear are specified below. Requirements for earphones and headphones intended for use with personal music players are also covered. A personal music player is a portable equipment intended for use by an ordinary person, that:</p> <ul style="list-style-type: none"> – is designed to allow the user to listen to audio or audiovisual content / material; and – uses a listening device, such as headphones or earphones that can be worn in or on or 		N/A

IEC62368_1E - ATTACHMENT

Clause	Requirement + Test	Result - Remark	Verdict
	<p>around the ears; and</p> <ul style="list-style-type: none"> – has a player that can be body worn (of a size suitable to be carried in a clothing pocket) and is intended for the user to walk around with while in continuous use (for example, on a street, in a subway, at an airport, etc.). <p>EXAMPLES Portable CD players, MP3 audio players, mobile phones with MP3 type features, PDAs or similar equipment.</p> <p>Personal music players shall comply with the requirements of either 10.6.2 or 10.6.3.</p> <p>NOTE 1 Protection against acoustic energy sources from telecom applications is referenced to ITU-T P.360.</p> <p>NOTE 2 It is the intention of the Committee to allow the alternative methods for now, but to only use the dose measurement method as given in 10.6.5 in future. Therefore, manufacturers are encouraged to implement 10.6.5 as soon as possible.</p> <p>Listening devices sold separately shall comply with the requirements of 10.6.6.</p> <p>These requirements are valid for music or video mode only.</p> <p>The requirements do not apply to:</p> <ul style="list-style-type: none"> – professional equipment; <p>NOTE 3 Professional equipment is equipment sold through special sales channels. All products sold through normal electronics stores are considered not to be professional equipment.</p> <ul style="list-style-type: none"> – hearing aid equipment and other devices for assistive listening; – the following type of analogue personal music players: <ul style="list-style-type: none"> • long distance radio receiver (for example, a multiband radio receiver or world band radio receiver, an AM radio receiver), and • cassette player/recorder; <p>NOTE 4 This exemption has been allowed because this technology is falling out of use and it is expected that within a few years it will no longer exist. This exemption will not be extended to other technologies.</p> <ul style="list-style-type: none"> – a player while connected to an external amplifier that does not allow the user to walk around while in use. <p>For equipment that is clearly designed or intended primarily for use by children, the limits of the relevant toy standards may apply.</p> <p>The relevant requirements are given in EN 71-1:2011, 4.20 and the related tests methods and measurement distances apply.</p>		
10.6.1.2	<p>Non-ionizing radiation from radio frequencies in the range 0 to 300 GHz</p>		N/A

IEC62368_1E - ATTACHMENT			
Clause	Requirement + Test	Result - Remark	Verdict
	<p>The amount of non-ionizing radiation is regulated by European Council Recommendation 1999/519/EC of 12 July 1999 on the limitation of exposure of the general public to electromagnetic fields (0 Hz to 300 GHz).</p> <p>For intentional radiators, ICNIRP guidelines should be taken into account for Limiting Exposure to Time-Varying Electric, Magnetic, and Electromagnetic Fields (up to 300 GHz). For hand-held and body mounted devices, attention is drawn to EN 50360 and EN 50566.</p>		
10.6.2	Classification of devices without the capacity to estimate sound dose		N/A
10.6.2.1	<p>General</p> <p>This standard is transitioning from short-term based (30 s) requirements to long-term based (40 hour) requirements. These clauses remain in effect only for devices that do not comply with sound dose estimation as stipulated in EN 50332-3.</p> <p>For classifying the acoustic output $L_{Aeq,T}$, measurements are based on the A-weighted equivalent sound pressure level over a 30 s period.</p> <p>For music where the average sound pressure (long term $L_{Aeq,T}$) measured over the duration of the song is lower than the average produced by the programme simulation noise, measurements may be done over the duration of the complete song. In this case, T becomes the duration of the song.</p> <p>NOTE Classical music, acoustic music and broadcast typically has an average sound pressure (long term $L_{Aeq,T}$) which is much lower than the average programme simulation noise. Therefore, if the player is capable to analyse the content and compare it with the programme simulation noise, the warning does not need to be given as long as the average sound pressure of the song does not exceed the required limit. For example, if the player is set with the programme simulation noise to 85 dB, but the average music level of the song is only 65 dB, there is no need to give a warning or ask an acknowledgement as long as the average sound level of the song is not above the basic limit of 85 dB.</p>		N/A
10.6.2.2	<p>RS1 limits (to be superseded, see 10.6.3.2)</p> <p>RS1 is a class 1 acoustic energy source that does not exceed the following:</p> <ul style="list-style-type: none"> – for equipment provided as a package (player with its listening device), and with a proprietary connector between the player and its listening device, or where the combination of player and listening device is known by other means such as setting or automatic detection, the $L_{Aeq,T}$ acoustic output shall be ≤ 85 dB when playing the fixed “programme simulation noise” described in EN 50332-1. 		N/A

IEC62368_1E - ATTACHMENT			
Clause	Requirement + Test	Result - Remark	Verdict
	<ul style="list-style-type: none"> – for equipment provided with a standardized connector (for example, a 3,5 phone jack) that allows connection to a listening device for general use, the unweighted r.m.s. output voltage shall be ≤ 27 mV (analogue interface) or -25 dBFS (digital interface) when playing the fixed “programme simulation noise” described in EN 50332-1. – The RS1 limits will be updated for all devices as per 10.6.3.2. 		
10.6.2.3	<p>RS2 limits (to be superseded, see 10.6.3.3)</p> <p>RS2 is a class 2 acoustic energy source that does not exceed the following:</p> <ul style="list-style-type: none"> – for equipment provided as a package (player with its listening device), and with a proprietary connector between the player and its listening device, or when the combination of player and listening device is known by other means such as setting or automatic 130 detection, the $L_{Aeq,T}$ acoustic output shall be ≤ 100 dB(A) when playing the fixed “programme simulation noise” as described in EN 50332-1. – for equipment provided with a standardized connector (for example, a 3,5 phone jack) that allows connection to a listening device for general use, the unweighted r.m.s. output voltage shall be ≤ 150 mV (analogue interface) or -10 dBFS (digital interface) when playing the fixed “programme simulation noise” as described in EN 50332-1. 		N/A
10.6.2.4	<p>RS3 limits</p> <p>RS3 is a class 3 acoustic energy source that exceeds RS2 limits.</p>		N/A
10.6.3	Classification of devices (new)		N/A
10.6.3.1	<p>General</p> <p>Previous limits (10.6.2) created abundant false negative and false positive PMP sound level warnings. New limits, compliant with The Commission Decision of 23 June 2009, are given below.</p>		N/A
10.6.3.2	<p>RS1 limits (new)</p> <p>RS1 is a class 1 acoustic energy source that does not exceed the following:</p> <ul style="list-style-type: none"> – for equipment provided as a package (player with its listening device), and with a proprietary connector between the player and its listening device, or where the combination of player and listening device is known by other means such as setting or automatic detection, the $L_{Aeq,T}$ acoustic output shall be ≤ 80 dB when playing the fixed “programme simulation noise” described in EN 50332-1. – for equipment provided with a standardized 		N/A

IEC62368_1E - ATTACHMENT			
Clause	Requirement + Test	Result - Remark	Verdict
	connector (for example, a 3,5 phone jack) that allows connection to a listening device for general use, the unweighted r.m.s. output voltage shall be ≤ 15 mV (analogue interface) or -30 dBFS (digital interface) when playing the fixed "programme simulation noise" described in EN 50332-1.		
10.6.3.3	<p>RS2 limits (new)</p> <p>RS2 is a class 2 acoustic energy source that does not exceed the following:</p> <ul style="list-style-type: none"> – for equipment provided as a package (player with its listening device), and with a proprietary connector between the player and its listening device, or where the combination of player and listening device is known by other means such as setting or automatic detection, the weekly sound exposure level, as described in EN 50332-3, shall be ≤ 80 dB when playing the fixed "programme simulation noise" described in EN 50332-1. – for equipment provided with a standardized connector (for example, a 3,5 phone jack) that allows connection to a listening device for general use, the unweighted r.m.s. output level, integrated over one week, as described in EN50332-3, shall be ≤ 15 mV (analogue interface) or -30 dBFS (digital interface) when playing the fixed "programme simulation noise" described in EN 50332-1. 		N/A
10.6.4	Requirements for maximum sound exposure		N/A
10.6.4.1	<p>Measurement methods</p> <p>All volume controls shall be turned to maximum during tests.</p> <p>Measurements shall be made in accordance with EN 50332-1 or EN 50332-2 as applicable.</p>		N/A
10.6.4.2	<p>Protection of persons</p> <p>Except as given below, protection requirements for parts accessible to ordinary persons, instructed persons and skilled persons are given in 4.3.</p> <p>NOTE 1 Volume control is not considered a safeguard.</p> <p>Between RS2 and an ordinary person, the basic safeguard may be replaced by an instructional safeguard in accordance with Clause F.5, except that the instructional safeguard shall be placed on the equipment, or on the packaging, or in the instruction manual.</p> <p>Alternatively, the instructional safeguard may be given through the equipment display during use.</p> <p>The elements of the instructional safeguard shall be as follows:</p>		N/A

IEC62368_1E - ATTACHMENT

Clause	Requirement + Test	Result - Remark	Verdict
	<p>– element 1a: the symbol , IEC 60417-6044 (2011-01)</p> <p>– element 2: “High sound pressure” or equivalent wording</p> <p>– element 3: “Hearing damage risk” or equivalent wording</p> <p>– element 4: “Do not listen at high volume levels for long periods.” or equivalent wording</p> <p>An equipment safeguard shall prevent exposure of an ordinary person to an RS2 source without intentional physical action from the ordinary person and shall automatically return to an output level not exceeding what is specified for an RS1 source when the power is switched off.</p> <p>The equipment shall provide a means to actively inform the user of the increased sound level when the equipment is operated with an output exceeding RS1. Any means used shall be acknowledged by the user before activating a mode of operation which allows for an output exceeding RS1. The acknowledgement does not need to be repeated more than once every 20 h of cumulative listening time.</p> <p>NOTE 2 Examples of means include visual or audible signals. Action from the user is always needed.</p> <p>NOTE 3 The 20 h listening time is the accumulative listening time, independent of how often and how long the personal music player has been switched off.</p> <p>A skilled person shall not be unintentionally exposed to RS3.</p>		
10.6.5	Requirements for dose-based systems		N/A
10.6.5.1	<p>General requirements</p> <p>Personal music players shall give the warnings as provided below when tested according to EN 50332-3, using the limits from this clause.</p> <p>The manufacturer may offer optional settings to allow the users to modify when and how they wish to receive the notifications and warnings to promote a better user experience without defeating the safeguards. This allows the users to be informed in a method that best meets their physical capabilities and device usage needs. If such optional settings are offered, an administrator (for example, parental restrictions, business/educational administrators, etc.) shall be able to lock any optional settings into a specific configuration.</p> <p>The personal music player shall be supplied with</p>		N/A

IEC62368_1E - ATTACHMENT			
Clause	Requirement + Test	Result - Remark	Verdict
	easy to understand explanation to the user of the dose management system, the risks involved, and how to use the system safely. The user shall be made aware that other sources may significantly contribute to their sound exposure, for example work, transportation, concerts, clubs, cinema, car races, etc.		
10.6.5.2	<p>Dose-based warning and requirements</p> <p>When a dose of 100 % <i>CSD</i> is reached, and at least at every 100 % further increase of <i>CSD</i>, the device shall warn the user and require an acknowledgement. In case the user does not acknowledge, the output level shall automatically decrease to compliance with class RS1.</p> <p>The warning shall at least clearly indicate that listening above 100 % <i>CSD</i> leads to the risk of hearing damage or loss.</p>		N/A
10.6.5.3	<p>Exposure-based requirements</p> <p>With only dose-based requirements, cause and effect could be far separated in time, defying the purpose of educating users about safe listening practice. In addition to dose-based requirements, a PMP shall therefore also put a limit to the short-term sound level a user can listen at.</p> <p>The exposure-based limiter (EL) shall automatically reduce the sound level not to exceed 100 dB(A) or 150 mV integrated over the past 180 s, based on methodology defined in EN 50332-3.</p> <p>The EL settling time (time from starting level reduction to reaching target output) shall be 10 s or faster.</p> <p>Test of EL functionality is conducted according to EN 50332-3, using the limits from this clause. For equipment provided as a package (player with its listening device), the level integrated over 180 s shall be 100 dB or lower. For equipment provided with a standardized connector, the unweighted level integrated over 180 s shall be no more than 150 mV for an analogue interface and no more than -10 dBFS for a digital interface.</p> <p>NOTE In case the source is known not to be music (or test signal), the EL may be disabled.</p>		N/A

IEC62368_1E - ATTACHMENT

Clause	Requirement + Test	Result - Remark	Verdict
10.6.6	Requirements for listening devices (headphones, earphones, etc.)		N/A
10.6.6.1	<p>Corded listening devices with analogue input</p> <p>With 94 dB L_{Aeq} acoustic pressure output of the listening device, and with the volume and sound settings in the listening device (for example, built-in volume level control, additional sound features like equalization, etc.) set to the combination of positions that maximize the measured acoustic output, the input voltage of the listening device when playing the fixed “programme simulation noise” as described in EN 50332-1 shall be ≥ 75 mV.</p> <p>NOTE The values of 94 dB and 75 mV correspond with 85 dB and 27 mV or 100 dB and 150 mV.</p>		N/A
10.6.6.2	<p>Corded listening devices with digital input</p> <p>With any playing device playing the fixed “programme simulation noise” described in EN 50332-1, and with the volume and sound settings in the listening device (for example, built-in volume level control, additional sound features like equalization, etc.) set to the combination of positions that maximize the measured acoustic output, the $L_{Aeq,T}$ acoustic output of the listening device shall be ≤ 100 dB with an input signal of -10 dBFS.</p>		N/A
10.6.6.3	<p>Cordless listening devices</p> <p>In cordless mode,</p> <ul style="list-style-type: none"> – with any playing and transmitting device playing the fixed programme simulation noise described in EN 50332-1; and – respecting the cordless transmission standards, where an air interface standard exists that specifies the equivalent acoustic level; and – with volume and sound settings in the receiving device (for example, built-in volume level control, additional sound features like equalization, etc.) set to the combination of positions that maximize the measured acoustic output for the above mentioned programme simulation noise, the $L_{Aeq,T}$ acoustic output of the listening device shall be ≤ 100 dB with an input signal of -10 dBFS. 		N/A
10.6.6.4	<p>Measurement method</p> <p><i>Measurements shall be made in accordance with EN 50332-2 as applicable.</i></p>		N/A
3	Modification to the whole document		—

IEC62368_1E - ATTACHMENT

Clause	Requirement + Test	Result - Remark	Verdict
--------	--------------------	-----------------	---------

	<p>Delete all the “country” notes in the reference document according to the following list:</p> <table border="1" data-bbox="427 427 1361 1200"> <tbody> <tr> <td>0.2.1</td> <td>Note 1 and 2</td> <td>1</td> <td>Note 4 and 5</td> <td>3.3.8.1</td> <td>Note 2</td> </tr> <tr> <td>3.3.8.3</td> <td>Note 1</td> <td>4.1.15</td> <td>Note</td> <td>4.7.3</td> <td>Note 1 and 2</td> </tr> <tr> <td>5.2.2.2</td> <td>Note</td> <td>5.4.2.3.2.2 Table 12</td> <td>Note c</td> <td>5.4.2.3.2.4</td> <td>Note 1 and 3</td> </tr> <tr> <td>5.4.2.3.2.4 Table 13</td> <td>Note 2</td> <td>5.4.2.5</td> <td>Note 2</td> <td>5.4.5.1</td> <td>Note</td> </tr> <tr> <td>5.4.10.2.1</td> <td>Note</td> <td>5.4.10.2.2</td> <td>Note</td> <td>5.4.10.2.3</td> <td>Note</td> </tr> <tr> <td>5.5.2.1</td> <td>Note</td> <td>5.5.6</td> <td>Note</td> <td>5.6.4.2.1</td> <td>Note 2 and 3 and 4</td> </tr> <tr> <td>5.6.8</td> <td>Note 2</td> <td>5.7.6</td> <td>Note</td> <td>5.7.7.1</td> <td>Note 1 and Note 2</td> </tr> <tr> <td>8.5.4.2.3</td> <td>Note</td> <td>10.2.1 Table 39</td> <td>Note 3 and 4 and 5</td> <td>10.5.3</td> <td>Note 2</td> </tr> <tr> <td>10.6.4</td> <td>Note 3</td> <td>F.3.3.6</td> <td>Note 3</td> <td>Y.4.1</td> <td>Note</td> </tr> <tr> <td>Y.4.5</td> <td>Note</td> <td></td> <td></td> <td></td> <td></td> </tr> </tbody> </table>	0.2.1	Note 1 and 2	1	Note 4 and 5	3.3.8.1	Note 2	3.3.8.3	Note 1	4.1.15	Note	4.7.3	Note 1 and 2	5.2.2.2	Note	5.4.2.3.2.2 Table 12	Note c	5.4.2.3.2.4	Note 1 and 3	5.4.2.3.2.4 Table 13	Note 2	5.4.2.5	Note 2	5.4.5.1	Note	5.4.10.2.1	Note	5.4.10.2.2	Note	5.4.10.2.3	Note	5.5.2.1	Note	5.5.6	Note	5.6.4.2.1	Note 2 and 3 and 4	5.6.8	Note 2	5.7.6	Note	5.7.7.1	Note 1 and Note 2	8.5.4.2.3	Note	10.2.1 Table 39	Note 3 and 4 and 5	10.5.3	Note 2	10.6.4	Note 3	F.3.3.6	Note 3	Y.4.1	Note	Y.4.5	Note						P
0.2.1	Note 1 and 2	1	Note 4 and 5	3.3.8.1	Note 2																																																										
3.3.8.3	Note 1	4.1.15	Note	4.7.3	Note 1 and 2																																																										
5.2.2.2	Note	5.4.2.3.2.2 Table 12	Note c	5.4.2.3.2.4	Note 1 and 3																																																										
5.4.2.3.2.4 Table 13	Note 2	5.4.2.5	Note 2	5.4.5.1	Note																																																										
5.4.10.2.1	Note	5.4.10.2.2	Note	5.4.10.2.3	Note																																																										
5.5.2.1	Note	5.5.6	Note	5.6.4.2.1	Note 2 and 3 and 4																																																										
5.6.8	Note 2	5.7.6	Note	5.7.7.1	Note 1 and Note 2																																																										
8.5.4.2.3	Note	10.2.1 Table 39	Note 3 and 4 and 5	10.5.3	Note 2																																																										
10.6.4	Note 3	F.3.3.6	Note 3	Y.4.1	Note																																																										
Y.4.5	Note																																																														
4	Modification to Clause 1		—																																																												
1	<p>Add the following note:</p> <p><i>NOTE Z1 The use of certain substances in electrical and electronic equipment is restricted within the EU: see Directive 2011/65/EU.</i></p>		P																																																												

IEC62368_1E - ATTACHMENT

Clause	Requirement + Test	Result - Remark	Verdict
--------	--------------------	-----------------	---------

5	Modification to 4.Z1		—
4.Z1	<p>Add the following new subclause after 4.9:</p> <p>To protect against excessive current, short-circuits and earth faults in circuits connected to an a.c. mains, protective devices shall be included either as integral parts of the equipment or as parts of the building installation, subject to the following, a), b) and c):</p> <p>a) except as detailed in b) and c), protective devices necessary to comply with the requirements of B.3.1 and B.4 shall be included as parts of the equipment;</p> <p>b) for components in series with the mains input to the equipment such as the supply cord, appliance coupler, r.f.i. filter and switch, short-circuit and earth fault protection may be provided by protective devices in the building installation;</p> <p>c) it is permitted for pluggable equipment type B or permanently connected equipment, to rely on dedicated overcurrent and short-circuit protection in the building installation, provided that the means of protection, e.g. fuses or circuit breakers, is fully specified in the installation instructions.</p> <p>If reliance is placed on protection in the building installation, the installation instructions shall so state, except that for pluggable equipment type A the building installation shall be regarded as providing protection in accordance with the rating of the wall socket outlet.</p>		P
6	Modification to 5.4.2.3.2.4		—
5.4.2.3.2.4	<p>Add the following to the end of this subclause:</p> <p>The requirement for interconnection with external circuit is in addition given in EN 50491-3:2009.</p>		P
7	Modification to 10.2.1		—
10.2.1	<p>Add the following to ^{c)} and ^{d)} in table 39:</p> <p>For additional requirements, see 10.5.1.</p>		N/A

IEC62368_1E - ATTACHMENT

Clause	Requirement + Test	Result - Remark	Verdict
--------	--------------------	-----------------	---------

8	Modification to 10.5.1		—
10.5.1	<p>Add the following after the first paragraph:</p> <p>For RS 1 compliance is checked by measurement under the following conditions:</p> <p>In addition to the normal operating conditions, all controls adjustable from the outside by hand, by any object such as a tool or a coin, and those internal adjustments or pre-sets which are not locked in a reliable manner, are adjusted so as to give maximum radiation whilst maintaining an intelligible picture for 1 h, at the end of which the measurement is made.</p> <p>NOTE Z1 Soldered joints and paint lockings are examples of adequate locking.</p> <p>The dose-rate is determined by means of a radiation monitor with an effective area of 10 cm², at any point 10 cm from the outer surface of the apparatus.</p> <p>Moreover, the measurement shall be made under fault conditions causing an increase of the high voltage, provided an intelligible picture is maintained for 1 h, at the end of which the measurement is made.</p> <p>For RS1, the dose-rate shall not exceed 1 µSv/h taking account of the background level.</p> <p>NOTE Z2 These values appear in Directive 96/29/Euratom of 13 May 1996.</p>		N/A
9	Modification to G.7.1		—
G.7.1	<p>Add the following note:</p> <p>NOTE Z1 The harmonized code designations corresponding to the IEC cord types are given in Annex ZD.</p>		N/A

IEC62368_1E - ATTACHMENT			
Clause	Requirement + Test	Result - Remark	Verdict

10	Modification to Bibliography		—
	<p>Add the following notes for the standards indicated:</p> <p>IEC 60130-9 NOTE Harmonized as EN 60130-9. IEC 60269-2 NOTE Harmonized as HD 60269-2. IEC 60309-1 NOTE Harmonized as EN 60309-1. IEC 60364 NOTE some parts harmonized in HD 384/HD 60364 series. IEC 60601-2-4 NOTE Harmonized as EN 60601-2-4. IEC 60664-5 NOTE Harmonized as EN 60664-5. IEC 61032:1997 NOTE Harmonized as EN 61032:1998 (not modified). IEC 61508-1 NOTE Harmonized as EN 61508-1. IEC 61558-2-1 NOTE Harmonized as EN 61558-2-1. IEC 61558-2-4 NOTE Harmonized as EN 61558-2-4. IEC 61558-2-6 NOTE Harmonized as EN 61558-2-6. IEC 61643-1 NOTE Harmonized as EN 61643-1. IEC 61643-21 NOTE Harmonized as EN 61643-21. IEC 61643-311 NOTE Harmonized as EN 61643-311. IEC 61643-321 NOTE Harmonized as EN 61643-321. IEC 61643-331 NOTE Harmonized as EN 61643-331.</p>		P
11	ADDITION OF ANNEXES		—
ZB	ANNEX ZB, SPECIAL NATIONAL CONDITIONS (EN)		—
4.1.15	<p>Denmark, Finland, Norway and Sweden</p> <p>To the end of the subclause the following is added: Class I pluggable equipment type A intended for connection to other equipment or a network shall, if safety relies on connection to reliable earthing or if surge suppressors are connected between the network terminals and accessible parts, have a marking stating that the equipment shall be connected to an earthed mains socket-outlet.</p> <p>The marking text in the applicable countries shall be as follows:</p> <p>In Denmark: "Apparatets stikprop skal tilsluttes en stikkontakt med jord som giver forbindelse til stikproppens jord." In Finland: "Laitte on liitettävä suojakoskettimilla varustettuun pistorasiaan" In Norway: "Apparatet må tilkoples jordet stikkontakt" In Sweden: "Apparaten skall anslutas till jordat uttag"</p>	N/A	

IEC62368_1E - ATTACHMENT

Clause	Requirement + Test	Result - Remark	Verdict
<p>4.7.3</p>	<p>United Kingdom</p> <p>To the end of the subclause the following is added:</p> <p>The torque test is performed using a socket-outlet complying with BS 1363, and the plug part shall be assessed to the relevant clauses of BS 1363. Also see Annex G.4.2 of this annex</p>		<p>N/A</p>
<p>5.2.2.2</p>	<p>Denmark</p> <p>After the 2nd paragraph add the following:</p> <p>A warning (marking safeguard) for high touch current is required if the touch current exceeds the limits of 3,5 mA a.c. or 10 mA d.c.</p>		<p>N/A</p>
<p>5.4.11.1 and Annex G</p>	<p>Finland and Sweden</p> <p>To the end of the subclause the following is added:</p> <p>For separation of the telecommunication network from earth the following is applicable:</p> <p>If this insulation is solid, including insulation forming part of a component, it shall at least consist of either</p> <ul style="list-style-type: none"> • two layers of thin sheet material, each of which shall pass the electric strength test below, or • one layer having a distance through insulation of at least 0,4 mm, which shall pass the electric strength test below. <p>If this insulation forms part of a semiconductor component (e.g. an optocoupler), there is no distance through insulation requirement for the insulation consisting of an insulating compound completely filling the casing, so that clearances and creepage distances do not exist, if the component passes the electric strength test in accordance with the compliance clause below and in addition</p> <ul style="list-style-type: none"> • passes the tests and inspection criteria of 5.4.8 with an electric strength test of 1,5 kV multiplied by 1,6 (the electric strength test of 5.4.9 shall be performed using 1,5 kV), <p>and</p> <ul style="list-style-type: none"> • is subject to routine testing for electric strength during manufacturing, using a test voltage of 1,5 kV. <p>It is permitted to bridge this insulation with a capacitor complying with EN 60384-14:2005, subclass Y2.</p> <p>A capacitor classified Y3 according to EN 60384-</p>		<p>N/A</p>

IEC62368_1E - ATTACHMENT

Clause	Requirement + Test	Result - Remark	Verdict
	<p>14:2005, may bridge this insulation under the following conditions:</p> <ul style="list-style-type: none"> the insulation requirements are satisfied by having a capacitor classified Y3 as defined by EN 60384-14, which in addition to the Y3 testing, is tested with an impulse test of 2,5 kV defined in 5.4.11; the additional testing shall be performed on all the test specimens as described in EN 60384-14; <p>the impulse test of 2,5 kV is to be performed before the endurance test in EN 60384-14, in the sequence of tests as described in EN 60384-14.</p>		
<p>5.5.2.1</p>	<p>Norway</p> <p>After the 3rd paragraph the following is added:</p> <p>Due to the IT power system used, capacitors are required to be rated for the applicable line-to-line voltage (230 V).</p>		<p>N/A</p>
<p>5.5.6</p>	<p>Finland, Norway and Sweden</p> <p>To the end of the subclause the following is added:</p> <p>Resistors used as basic safeguard or bridging basic insulation in class I pluggable equipment type A shall comply with G.10.1 and the test of G.10.2.</p>		<p>N/A</p>
<p>5.6.1</p>	<p>Denmark</p> <p>Add to the end of the subclause</p> <p>Due to many existing installations where the socket-outlets can be protected with fuses with higher rating than the rating of the socket-outlets the protection for pluggable equipment type A shall be an integral part of the equipment.</p> <p><i>Justification:</i></p> <p>In Denmark an existing 13 A socket outlet can be protected by a 20 A fuse.</p>		<p>N/A</p>
<p>5.6.4.2.1</p>	<p>Ireland and United Kingdom</p> <p>After the indent for pluggable equipment type A, the following is added:</p> <p>– the protective current rating is taken to be 13 A, this being the largest rating of fuse used in the mains plug.</p>		<p>N/A</p>
<p>5.6.4.2.1</p>	<p>France</p> <p>After the indent for pluggable equipment type A, the following is added:</p> <p>– in certain cases, the protective current rating of the circuit supplied from the mains is taken as 20 A instead of 16 A.</p>		<p>N/A</p>

IEC62368_1E - ATTACHMENT

Clause	Requirement + Test	Result - Remark	Verdict
5.6.5.1	<p>To the second paragraph the following is added:</p> <p>The range of conductor sizes of flexible cords to be accepted by terminals for equipment with a rated current over 10 A and up to and including 13 A is: 1,25 mm² to 1,5 mm² in cross-sectional area.</p>		N/A
5.6.8	<p>Norway</p> <p>To the end of the subclause the following is added: Equipment connected with an earthed mains plug is classified as class I equipment. See the Norway marking requirement in 4.1.15. The symbol IEC 60417-6092, as specified in F.3.6.2, is accepted.</p>		N/A
5.7.6	<p>Denmark</p> <p>To the end of the subclause the following is added:</p> <p>The installation instruction shall be affixed to the equipment if the protective conductor current exceeds the limits of 3,5 mA a.c. or 10 mA d.c.</p>		N/A
5.7.6.2	<p>Denmark</p> <p>To the end of the subclause the following is added: The warning (marking safeguard) for high touch current is required if the touch current or the protective current exceed the limits of 3,5 mA .</p>		N/A

DRAFT

IEC62368_1E - ATTACHMENT

Clause	Requirement + Test	Result - Remark	Verdict
--------	--------------------	-----------------	---------

<p>5.7.7.1</p>	<p>Norway and Sweden</p> <p>To the end of the subclause the following is added: The screen of the television distribution system is normally not earthed at the entrance of the building and there is normally no equipotential bonding system within the building. Therefore the protective earthing of the building installation needs to be isolated from the screen of a cable distribution system.</p> <p>It is however accepted to provide the insulation external to the equipment by an adapter or an interconnection cable with galvanic isolator, which may be provided by a retailer, for example.</p> <p>The user manual shall then have the following or similar information in Norwegian and Swedish language respectively, depending on in what country the equipment is intended to be used in:</p> <p>“Apparatus connected to the protective earthing of the building installation through the mains connection or through other apparatus with a connection to protective earthing – and to a television distribution system using coaxial cable, may in some circumstances create a fire hazard. Connection to a television distribution system therefore has to be provided through a device providing electrical isolation below a certain frequency range (galvanic isolator, see EN 60728-11)”</p> <p>NOTE In Norway, due to regulation for CATV-installations, and in Sweden, a galvanic isolator shall provide electrical insulation below 5 MHz. The insulation shall withstand a dielectric strength of 1,5 kV r.m.s., 50 Hz or 60 Hz, for 1 min.</p> <p>Translation to Norwegian (the Swedish text will also be accepted in Norway):</p> <p>“Apparater som er koplet til beskyttelsesjord via nettplugg og/eller via annet jordtilkøplet utstyr – og er tilkøplet et koaksialbasert kabel-TV nett, kan forårsake brannfare. For å unngå dette skal det ved tilkopling av apparater til kabel-TV nett installeres en galvanisk isolator mellom apparatet og kabel-TV nettet.”</p> <p>Translation to Swedish: ”Apparater som är kopplad till skyddsjord via jordat vägguttag och/eller via annan utrustning och samtidigt är kopplad till kabel-TV nät kan i vissa fall medföra risk för brand. För att undvika detta skall vid anslutning av apparaten till kabel-TV nät</p>		<p>N/A</p>
-----------------------	--	--	------------

IEC62368_1E - ATTACHMENT

Clause	Requirement + Test	Result - Remark	Verdict
	galvanisk isolator finnas mellan apparaten och kabel-TV nätet.”.		
<p>8.5.4.2.3</p>	<p>United Kingdom</p> <p>Add the following after the 2nd dash bullet in 3rd paragraph:</p> <p>An emergency stop system complying with the requirements of IEC 60204-1 and ISO 13850 is required where there is a risk of personal injury.</p>		<p>N/A</p>
<p>B.3.1 and B.4</p>	<p>Ireland and United Kingdom</p> <p>The following is applicable:</p> <p>To protect against excessive currents and short-circuits in the primary circuit of direct plug-in equipment, tests according to Annexes B.3.1 and B.4 shall be conducted using an external miniature circuit breaker complying with EN 60898-1, Type B, rated 32A. If the equipment does not pass these tests, suitable protective devices shall be included as an integral part of the direct plug-in equipment, until the requirements of Annexes B.3.1 and B.4 are met</p>		<p>N/A</p>

DRAFT

IEC62368_1E - ATTACHMENT

Clause	Requirement + Test	Result - Remark	Verdict
--------	--------------------	-----------------	---------

<p>G.4.2</p>	<p>Denmark</p> <p>To the end of the subclause the following is added:</p> <p>Supply cords of single phase appliances having a rated current not exceeding 13 A shall be provided with a plug according to DS 60884-2-D1:2011.</p> <p>CLASS I EQUIPMENT provided with socket-outlets with earth contacts or which are intended to be used in locations where protection against indirect contact is required according to the wiring rules shall be provided with a plug in accordance with standard sheet DK 2-1a or DK 2-5a.</p> <p>If a single-phase equipment having a RATED CURRENT exceeding 13 A or if a polyphase equipment is provided with a supply cord with a plug, this plug shall be in accordance with the standard sheets DK 6-1a in DS 60884-2-D1 or EN 60309-2.</p> <p>Mains socket outlets intended for providing power to Class II apparatus with a rated current of 2,5 A shall be in accordance DS 60884-2-D1:2011 standard sheet DKA 1-4a.</p> <p>Other current rating socket outlets shall be in compliance with Standard Sheet DKA 1-3a or DKA 1-1c.</p> <p>Mains socket-outlets with earth shall be in compliance with DS 60884-2-D1:2011 Standard Sheet DK 1-3a, DK 1-1c, DK1-1d, DK 1-5a or DK 1-7a</p> <p><i>Justification:</i> Heavy Current Regulations, Section 6c</p>		<p>N/A</p>
<p>G.4.2</p>	<p>United Kingdom</p> <p>To the end of the subclause the following is added:</p> <p>The plug part of direct plug-in equipment shall be assessed to BS 1363: Part 1, 12.1, 12.2, 12.3, 12.9, 12.11, 12.12, 12.13, 12.16, and 12.17, except that the test of 12.17 is performed at not less than 125 °C. Where the metal earth pin is replaced by an Insulated Shutter Opening Device (ISOD), the requirements of clauses 22.2 and 23 also apply.</p>		<p>N/A</p>

IEC62368_1E - ATTACHMENT

Clause	Requirement + Test	Result - Remark	Verdict
<p>G.7.1</p>	<p>United Kingdom</p> <p>To the first paragraph the following is added:</p> <p>Equipment which is fitted with a flexible cable or cord and is designed to be connected to a mains socket conforming to BS 1363 by means of that flexible cable or cord shall be fitted with a 'standard plug' in accordance with the Plugs and Sockets etc. (Safety) Regulations 1994, Statutory Instrument 1994 No. 1768, unless exempted by those regulations.</p> <p>NOTE "Standard plug" is defined in SI 1768:1994 and essentially means an approved plug conforming to BS 1363 or an approved conversion plug.</p>		<p>N/A</p>
<p>G.7.1</p>	<p>Ireland</p> <p>To the first paragraph the following is added:</p> <p>Apparatus which is fitted with a flexible cable or cord shall be provided with a plug in accordance with Statutory Instrument 525: 1997, "13 A Plugs and Conversion Adapters for Domestic Use Regulations: 1997. S.I. 525 provides for the recognition of a standard of another Member State which is equivalent to the relevant Irish Standard</p>		<p>N/A</p>
<p>G.7.2</p>	<p>Ireland and United Kingdom</p> <p>To the first paragraph the following is added:</p> <p>A power supply cord with a conductor of 1,25 mm² is allowed for equipment which is rated over 10 A and up to and including 13 A.</p>		<p>N/A</p>
<p>ZC</p>	<p>ANNEX ZC, NATIONAL DEVIATIONS (EN)</p>		<p>—</p>
<p>10.5.2</p>	<p>Germany</p> <p>The following requirement applies:</p> <p>For the operation of any cathode ray tube intended for the display of visual images operating at an acceleration voltage exceeding 40 kV, authorization is required, or application of type approval (Bauartzulassung) and marking.</p> <p><i>Justification:</i> German ministerial decree against ionizing radiation (Röntgenverordnung), in force since 2002-07-01, implementing the European Directive 96/29/EURATOM.</p> <p>NOTE Contact address: Physikalisch-Technische Bundesanstalt, Bundesallee 100, D-38116 Braunschweig, Tel.: Int+49-531-592-6320, Internet: http://www.ptb.de</p>		<p>N/A</p>

IEC62368_1E - ATTACHMENT

Clause	Requirement + Test	Result - Remark	Verdict
--------	--------------------	-----------------	---------

ZD	IEC and CENELEC CODE DESIGNATIONS FOR FLEXIBLE CORDS (EN)		—	
	Type of flexible cord	Code designations		N/A
		IEC	CENELEC	
	PVC insulated cords			
	Flat twin tinsel cord	60227 IEC 41	H03VH-Y	
	Light polyvinyl chloride sheathed flexible cord	60227 IEC 52	H03VV-F H03VVH2-F	
	Ordinary polyvinyl chloride sheathed flexible cord	60227 IEC 53	H05VV-F H05VVH2-F	
	Rubber insulated cords			
	Braided cord	60245 IEC 51	H03RT-F	
	Ordinary tough rubber sheathed flexible cord	60245 IEC 53	H05RR-F	
	Ordinary polychloroprene sheathed flexible cord	60245 IEC 57	H05RN-F	
	Heavy polychloroprene sheathed flexible cord	60245 IEC 66	H07RN-F	
	Cords having high flexibility			
	Rubber insulated and sheathed cord	60245 IEC 86	H03RR-H	
	Rubber insulated, crosslinked PVC sheathed cord	60245 IEC 87	H03RV4-H	
	Crosslinked PVC insulated and sheathed cord	60245 IEC 88	H03V4V4-H	
	Cords insulated and sheathed with halogen-free thermoplastic compounds			
	Light halogen-free thermoplastic insulated and sheathed flexible cords		H03Z1Z 1-F H03Z1Z 1H2-F	
	Ordinary halogen-free thermoplastic insulated and sheathed flexible cords		H05Z1Z 1-F H05Z1Z 1H2-F	

-- End of Attachment 1 --

IEC62368_1E - ATTACHMENT

Clause	Requirement + Test	Result - Remark	Verdict
--------	--------------------	-----------------	---------

Attachment 2 U.S.A. AND CANADA NATIONAL DIFFERENCES

<p align="center">ATTACHMENT TO TEST REPORT IEC 62368-1 U.S.A. AND CANADA NATIONAL DIFFERENCES (Audio/video, information and communication technology equipment – Part 1: Safety requirements)</p>			
Differences according to: CSA/UL 62368-1:2019			
TRF template used: IECEE OD-2020-F3, Ed. 1.1			
Attachment Form No: US_CA_ND_IEC62368_1E			
Attachment Originator: UL(US)			
Master Attachment: Dated 2022-03-04			
Copyright © 2022 IEC System for Conformity Testing and Certification of Electrical Equipment (IECEE), Geneva, Switzerland. All rights reserved.			
<p align="center">IEC 62368-1 - US and Canadian National Differences Special National Conditions based on Regulations and Other National Differences</p>			
1 (1DV.1) (1.3)	All equipment is to be designed to allow installation in accordance with the National Electrical Code (NEC), ANSI/NFPA 70, the Canadian Electrical Code (CEC), Part 1, CAN/CSA C22.1, and when applicable, the National Electrical Safety Code, IEEE C2. Also, for such equipment marked or otherwise identified, installation is allowed per the Standard for the Protection of Information Technology Equipment, ANSI/NFPA 75.	Considered.	P
1 (1DV.2.1)	This standard includes additional requirements for equipment used for entertainment purposes intended for installation in general patient care areas of health care facilities. See Annex DVB.	Not such equipment.	N/A
1 (1DV.2.2)	This standard includes additional requirements for equipment intended for mounting under cabinets. See Annex DVC.	Not such equipment.	N/A
1 (1DV.2.3)	IEC 62368-3 clause 5 for DC power transfer at ES1 or ES2 voltage levels is considered informative. IEC 62368-3 clause 6 for remote power feeding telecommunication (RFT) circuits is considered normative (see ITU K.50). Alternatively, equipment with RFT circuits are given in either UL 2391 or CSA/UL 60950-21. RFT-C circuits are not permitted unless the RFT-C circuit complies with RFT-V limits ($\leq 200V$ per conductor to earth).	Not such circuits.	N/A

IEC62368_1E - ATTACHMENT

Clause	Requirement + Test	Result - Remark	Verdict
1 (1DV.3)	For protection against direct lightning strikes, reference is made to NFPA 780 and CAN/CSA-B72 for additional requirements.	No such parts.	N/A
1 (DV.5)	Additional requirements apply to some forms of power distribution equipment, including sub-assemblies.	No such parts.	N/A
4.1 (4.1.17)	For lengths exceeding 3.05 m, external interconnecting cable assemblies are required to be a suitable cable type (e.g., DP, CL2) specified in the NEC.	No such cable or wiring.	N/A
	For lengths 3.05 m or less, external interconnecting cable assemblies that are not types specified in the NEC generally are required to have special construction features and identification markings.	No such cable or wiring.	N/A
4.6 (4.6.2)	Wire-wrap terminals have special construction and performance requirements.	No such parts.	N/A
4.8 (4.8.3, 4.8.4.5, 4.8.5)	Coin / button cell batteries have modified special construction and performance requirements.	No such parts.	N/A
5.4.2.3.2 (5.4.2.3.2.1)	Surge Arrestors and Transient Voltage Surge Suppressors installed external to the equipment are required to comply with the appropriate NEC and CEC requirements.	Not such equipment.	N/A
5.5.9	Receptacles, rated 125-V, single phase, 15- or 20-A accessible to either ordinary, instructed, or skilled persons are required to be provided with GFCI Protection for Personnel if the equipment containing the receptacles is installed outdoors. The protection devices are required to comply with UL 943, and CAN/CSA C22.2 No.144.	Not such equipment.	N/A
5.6.3	Protective earthing conductors comply with the minimum conductor sizes in Table G.7, except as required by Table G.7ADV.1 for cord connected equipment, or Annex DVH for permanently connected equipment.	An appliance inlet provided.	N/A
5.7.8 (5.7.8.1)	Equipment intended to receive telecommunication ringing signals is required to comply with a special touch current measurement tests.	Not such equipment.	N/A
6.5.1	PS3 wiring outside a fire enclosure is required to comply with single fault testing in B.4, or be current limited per one of the permitted methods.	Not applicable.	N/A

IEC62368_1E - ATTACHMENT

Clause	Requirement + Test	Result - Remark	Verdict
Annex F (F.3.3.9)	Output terminals provided for supply of other equipment, except mains supply, are required to be marked with a maximum rating or reference to equipment permitted to be connected.	No such power sourcing ports.	N/A
Annex F (F.3.7)	Outdoor Enclosures are required to be classified and marked in accordance with UL 50 or 50E, or CAN/CSA C22.2 No. 94.1 or 94.2.	Not such equipment.	N/A
Annex G (G.7)	Permanent connection of equipment to the mains supply by a power supply cord is not permitted, except for certain equipment, such as ATMs.	Not such equipment.	N/A
	Power supply cords are required to have attachment plugs rated not less than 125 percent of the rated current of the equipment.		N/A
	Flexible power supply cords are required to be compatible with Article 400 of the NEC, and Tables 11 and 12 of the CEC.		N/A
	Minimum cord length is required to be 1.5 m, with certain constructions such as external power supplies allowed to consider both input and output cord lengths into the requirement. Power supply cords are required to be no longer than 4.5 m in length if used in ITE Rooms.		N/A
	Power supply cords for outdoor equipment are required to be suitable outdoor use type as required by Section 400.4 of the NEC and Rule 4-012 of the CEC, i.e., marked "W."		N/A
Annex H.2	Continuous ringing signals under normal operating conditions up to 16 mA only are permitted if the equipment is subjected to special installation and performance restrictions.	No external circuits.	N/A
Annex H.4	For circuits with other than ringing signals and with voltages exceeding 42.4 V _{peak} or 60 V _{d.c.} , the maximum acceptable current through a 2000 ohm resistor (or greater) connected across the voltage source with other loads disconnected is 7.1 mA peak or 30 mA d.c. under normal operating conditions.	No external circuits.	N/A
Annex Q (Q.3)	Equipment with paired conductor and/or coax communications cables/wiring connected to building wiring are required to have special voltage, current, power and marking requirements.	Not such equipment.	N/A

IEC62368_1E - ATTACHMENT

Clause	Requirement + Test	Result - Remark	Verdict
Annex DVA (1)	Equipment that is designed such that it may be powered from a separate electrical service, is required to meet applicable requirements for service equipment for control and protection of services and their installation and complies with Article 230 of the National Electrical Code (NEC), NFPA 70 and Section 6 of the Canadian Electrical Code, Part I, CSA C22.1.	Not such equipment.	N/A
	Equipment intended for use in spaces used for environmental air (plenums) are subjected to special flammability requirements for heat and visible smoke release.	Not applicable.	N/A
	For ITE room applications, automated information storage systems with combustible media greater than 0.76 m ³ (27 cu ft) are required to have a provision for connection of either automatic sprinklers or a gaseous agent extinguishing system with an extended discharge.	Not applicable.	N/A
	Consumer products designed or intended primarily for children 12 years of age or younger are subject to additional requirements in accordance with U.S. and Canadian Regulations.	Not applicable.	N/A
	Baby monitors are required to additionally comply with ASTM F2951, Consumer Safety Specification for Baby Monitors.	Not applicable.	N/A
	Storage batteries and battery management equipment, other than associated with lead-acid batteries, and including battery backup systems that are not an integral part of stationary AV and ICT equipment, such as provided in separate cabinets, are required to be certified (listed) to the appropriate standard(s) for such storage batteries and equipment.	Not applicable.	N/A
Annex DVA (5.6)	For Pluggable Equipment Type A, the protection in the installation is assumed to be 20A.		P
Annex DVA (6.3)	The maximum quantity of flammable liquid stored in equipment is required to comply with NFPA 30.	No flammability liquid.	N/A

IEC62368_1E - ATTACHMENT

Clause	Requirement + Test	Result - Remark	Verdict
Annex DVA (6.4.8)	For ITE room applications, enclosures with combustible material measuring greater than 0.9 m ² (10 sq ft) or a single dimension greater than 1.8 m (6 ft) are required to have a flame spread rating of 50 or less. For equipment with the same dimensions for other applications, an external surface that is not a fire enclosure requires a minimum flammability classification of V-1.	Not applicable.	N/A
Annex DVA (10.3)	Equipment with lasers is required to meet the U.S. Code of Federal Regulations 21 CFR 1040 (and the Canadian Radiation Emitting Devices Act, REDR C1370).	Not such laser in the equipment.	N/A
Annex DVA (10.5)	Equipment that produces ionizing radiation is required to comply with the U.S. Code of Federal Regulations, 21 CFR 1020 (and the Canadian Radiation Emitting Devices Act, REDR C1370).	Not such radiation in the equipment.	N/A
Annex DVA (F.3.3.4)	Equipment for use on a.c. mains supply systems with a neutral and more than one phase conductor (e.g. 120/240 V, 3-wire) require a special marking format for electrical ratings. Additional considerations apply for voltage ratings that exceed the attachment cap rating or that are lower than the "Normal Operating Condition" in Table 2 of CAN/CSA C22.2 No. 235."	No such parts.	N/A
Annex DVA (F.3.3.6)	Equipment identified for ITE (computer) room installation is required to be marked with the rated current.	Not applicable.	N/A
Annex DVA (G.1)	Vertically-mounted disconnect switches and circuit breakers are required to have the "on" position indicated by the handle in the up position, where mounted in an enclosure, vertically mounted disconnect switches and circuit breakers with vertical operating means extending outside the enclosure are required to indicate in a location visible when accessing the external operating means whether the switch or circuit breaker is in the open (off) or closed (on) position.	No switch.	N/A
Annex DVA (G.3.4)	Suitable NEC/CEC branch circuit protection rated at the maximum circuit rating is required for all standard supply outlets and receptacles (such as supplied in power distribution units) if the supply branch circuit protection is not suitable.	No such parts.	N/A
	Where a fuse is used to provide Class 2 or Class 3 current limiting, it is not operator-accessible unless it is non- interchangeable.		N/A

IEC62368_1E - ATTACHMENT

Clause	Requirement + Test	Result - Remark	Verdict
Annex DVA (G.4.2)	Equipment with isolated ground (earthing) receptacles is required to comply with NEC 250.146(D) and CEC 10-400 and 10-612.	No such parts.	N/A
Annex DVA (G.4.3)	Interconnection of units by conductors supplied by a limited power source, or a Class 2 circuit defined in the NEC/CEC may have field wiring connections other than specified in DVH.3, such as wire-wrap and crimp-on types, if the limited power source and Class 2 circuits are separated from all other circuits by barriers, routing or fixing.	No such parts.	N/A
Annex DVA (G.5.3)	Power distribution transformers distributing power at 100 volts or more, and rated 10 kVA or more, require special transformer overcurrent protection.	No such parts.	N/A
Annex DVA (G.5.4)	Motor control devices are required for cord-connected equipment with a mains-connected motor if the equipment is rated more than 12 A, or if the equipment has a nominal voltage rating greater than 120 V, or if the motor is rated more than 1/3 hp (locked rotor current over 43 A).	No such parts.	N/A
Annex DVA (G.7)	Flexible cords used outdoors are required to have the suffix "W" marked on the flexible cord.	No such parts.	N/A
Annex DVA (M)	For ITE room applications, equipment with battery systems capable of supplying 750 VA for five minutes are required to have a battery disconnect means that may be connected to the ITE room remote power-off circuit.	No such parts.	N/A
Annex DVA (Q)	If applicable per NEC 725.121(C), some limited power sources supplied from AV/ICT equipment are required to have a label indicating the maximum voltage and rated current output for per conductor for each connection point. Where multiple connection points have the same rating, a single label is permitted to be used.	No such parts.	N/A
	Wiring terminals intended to supply Class 2 outputs in accordance with the NEC or CEC Part 1 are required to be marked with the voltage rating and "Class 2" or equivalent. The marking is located adjacent to the terminals and visible during wiring.	No such parts.	N/A
	Applicable parts of Chapter 8 of the NEC, and Rules 54 and 60 of the CEC, may be applicable to ITE installed outdoors with connections to communication systems.	No such equipment.	N/A

IEC62368_1E - ATTACHMENT

Clause	Requirement + Test	Result - Remark	Verdict
Annex DVB (1)	Additional requirements apply for equipment used for entertainment purposes intended for installation in general patient care areas of health care facilities.	Not applicable.	N/A
Annex DVC (1)	Additional requirements apply for equipment intended for mounting under kitchen cabinets.	Not applicable.	N/A
Annex DVE (4.1.1)	Some equipment, components, sub-assemblies and materials associated with the risk of fire, electric shock, or personal injury are required to have component or material ratings in accordance with the applicable national (U.S. and Canadian) component or material requirements. These equipment and components include: appliance couplers, attachment plugs, battery backup systems, circuit breakers, communication circuit accessories, connectors (used for current interruption of non-LPS circuits), direct plug-in equipment, electrochemical capacitor modules (energy storage modules with ultracapacitors), enclosures (outdoor), flexible cords and cables, fuses (branch circuit), ground-fault current interrupters, interconnecting cables, modular data centres, power supply cords, some power distribution equipment, printed wiring, protectors for communications circuits, receptacles, surge protective devices, vehicle battery adapters, wire connectors, and wire and cables.	No such parts.	N/A
Annex DVH	Equipment for permanent connection to the mains supply is subjected to additional requirements.	Not permanent connection.	N/A
Annex DVH (DVH.1)	Wiring methods (terminals, leads, etc.) used for the connection of the equipment to the mains are required to be in accordance with the NEC/CEC.	No such wiring terminal.	P
Annex DVH (DVH.2.1)	For safe and reliable connection to a mains, permanently connected equipment is to be provided.	Not permanent connection.	N/A
Annex DVH (DVH.2.2)	Additional considerations for D.C. mains.		N/A
Annex DVH (DVH.3.2.1)	Terminals for permanent wiring, including protective earthing terminals, are required to be suitable for U.S./Canadian wire gauge sizes, rated 125 percent of the equipment rating, and be specially marked when specified.	Not permanent connection.	N/A
Annex DVH (DVH.3.2.3)	Wire binding screws are not permitted to attach conductors larger than 10 AWG (5.3 mm ²).	No such wiring terminal.	N/A

IEC62368_1E - ATTACHMENT

Clause	Requirement + Test	Result - Remark	Verdict
Annex DVH (DVH.3.2.4)	All associated mains supply terminals are located in proximity to each other and to the main protective earthing terminal, if any.		N/A
Annex DVH (DVH.3.2.5)	Terminals are located, guarded or insulated so that, should a strand of a conductor escape when the conductor is fitted, there is no likelihood of accidental contact between such a strand and accessible conductive parts or unearthed conductive parts separated from accessible conductive parts by supplementary insulation only.		N/A
Annex DVH (DVH.3.3)	When field connection to an external circuit is via wires (example, free conductors), the wires are not smaller than 18 AWG (0.82 mm ²) and the free length of the wire inside an outlet box or wiring compartment is 150 mm or more.		N/A
Annex DVH (DVH.3.4)	Size of protective earthing conductors and terminals		N/A
Annex DVH (DVH.4)	Permanently connected equipment is required to have a suitable wiring compartment and wire bending space.	No such wiring terminal.	N/A
Annex DVH (DVH.4.1)	Wire bending space		N/A
Annex DVH (DVH.4.2)	Volume of wiring compartment		N/A
Annex DVH (DVH.4.3)	Separation of circuits		N/A
Annex DVH (DVH.5)	Equipment markings and instructional safeguards		P
Annex DVH (DVH.5.1)	Identification of protective earthing terminal		N/A
Annex DVH (DVH.5.2)	Identification of terminal for earthed conductor (neutral)		N/A
Annex DVH (DVH.5.3)	Identification of terminals for aluminium conductors		N/A
Annex DVH (DVH.5.4)	Wire temperature ratings		N/A
Annex DVH (DVH 5.5)	Equipment connected to a centralized d.c. power system, and having one pole of the DC mains input terminal connected to the main protective earthing terminal in the equipment, is required to comply with special earthing, wiring, marking and installation instruction requirements.	This equipment doesn't to be connected to a centralized d.c. power system.	N/A
Annex DVI (6.7)	Equipment intended for connection to telecommunication network outside plant cable is required to be protected against overvoltage from power line crosses.	This equipment without telecommunication circuits.	N/A

IEC62368_1E - ATTACHMENT

Clause	Requirement + Test	Result - Remark	Verdict
Annex DVJ (10.6.1)	Equipment connected to a telecommunication and cable distribution networks and supplied with an earphone intended to be held against, or in the ear is required to comply with special acoustic pressure requirements.	This equipment without telecommunication circuits.	N/A

-- End of Attachment 2 --

DRAFT

IEC62368_1E - ATTACHMENT

Clause	Requirement + Test	Result - Remark	Verdict
--------	--------------------	-----------------	---------

Attachment 3 Australia / New Zealand National Differences

ATTACHMENT TO TEST REPORT			
IEC 62368-1 (AUSTRALIA / NEW ZEALAND) NATIONAL DIFFERENCES (Audio/video, information and communication technology equipment)			
Differences according to : AS/NZS 62368.1:2022			
TRF template used:.....: IECCE OD-2020-F3, Ed. 1.1			
Attachment Form No. : AU_NZ_ND_IEC62368_1E			
Attachment Originator : JAS-ANZ			
Master Attachment : 2022-07-01			
Copyright © 2020 IEC System for Conformity Testing and Certification of Electrical Equipment (IECEE), Geneva, Switzerland. All rights reserved.			
	National Differences		—
Appendix ZZ	Variations to IEC 62368-1:2018 (ED. 3.0) for Australia and New Zealand		—
ZZ1 Scope	This Appendix lists the normative variations to IEC 62368-1:2018 (ED. 3.0)		—
ZZ2 Variations	The following modifications are required for Australian/New Zealand conditions:		—
2	After the first paragraph, <i>add</i> the following: The Australian or Australian/New Zealand Standards listed below are modified adoptions of, or not equivalent to, the IEC normative references and are required for the application of this Standard. All references in the source text to those IEC normative references shall be replaced by references to the corresponding Australian or Australian/New Zealand Standards. Australian or Australian/New Zealand Standards that are identical adoptions of international normative references may be used interchangeably -AS/NZS 3112, <i>Approval and test specification—Plugs and socket-outlets</i> -AS/NZS 3123, <i>Approval and test specification—Plugs, socket-outlets and couplers for general industrial application</i> -AS/NZS 3191, <i>Electric flexible cords</i> -AS/NZS 60884.1, <i>Plugs and socket-outlets for household and similar purposes, Part 1: General requirements</i> -IEC 60086-2 <i>Primary batteries — Part 2: Physical and electrical specifications</i>		P

IEC62368_1E - ATTACHMENT

Clause	Requirement + Test	Result - Remark	Verdict
	<p>-AS/NZS 60065, <i>Audio, video and similar electronic apparatus—Safety requirements (IEC 60065:2015 (ED.8.0) MOD)</i></p> <p>-AS/NZS 60320.1, <i>Appliance couplers for household and similar general purposes, Part 1: General requirements (IEC 60320-1, Ed.2.1 (2007) MOD)</i></p> <p>-AS/NZS 60320.2.2, <i>Appliance couplers for household and similar general purposes Part 2.2: Interconnection couplers for household and similar equipment (IEC 60320-2-2, Ed.2.0 (1998) MOD)</i></p> <p>-AS/NZS 60695.2.11, <i>Fire hazard testing, Part 2.11: Glowing/hot wire based test methods—Glow-wire flammability test method for end-products</i></p> <p>-AS/NZS 60695.11.5, <i>Fire hazard testing, Part 11.5: Test flames—Needle-flame test method—Apparatus, confirmatory test arrangement and guidance</i></p> <p>-AS/NZS 60695.11.10, <i>Fire hazard testing, Part 11.10: Test flames—50 W horizontal and vertical flame test methods</i></p> <p>-AS/NZS 60884.1, <i>Plugs and socket-outlets for household and similar purposes, Part 1: General requirements</i></p> <p>-AS/NZS 60950.1, <i>Information technology equipment—Safety, Part 1: General requirements (IEC 60950-1, Ed.2.2 (2013), MOD)</i></p> <p>IEC 61032:1997, <i>Protection of persons and equipment by enclosures—Probes for verification</i></p> <p>-AS/NZS 61558.1, <i>Safety of Power Transformers, Power Supplies, Reactors and Similar Products, Part 1: General requirements and tests (IEC 61558-1 Ed 3, MOD)</i></p> <p>-AS/NZS 61558.2.16, <i>Safety of transformers, reactors, power supply units and similar products for voltages up to 1 100 V, Part 2.16: Particular requirements and tests for switch mode power supply units and transformers for switch mode power supply units.</i></p>		

IEC62368_1E - ATTACHMENT

Clause	Requirement + Test	Result - Remark	Verdict		
4.7.2	<p>Requirements</p> <p>Delete the text of the second paragraph and replace with the following: Equipment with a plug portion, suitable for insertion into a 10 A 3-pin flat-pin socket-outlet conforming to AS/NZS 3112, shall conform to the requirements in AS/NZS 3112 for equipment with integral pins for insertion into socket-outlets. Conformity is checked by inspection and, if necessary, by the tests in AS/NZS 3112. NOTE: Equipment with plug portions for use in countries other than Australia and New Zealand will need to conform to other countries' requirements Note Additional AS/NZS 3112 Appendix J,TRF is appended to end of this TRF.</p>		N/A		
4.7.3	<p>Compliance Criteria</p> <p>Delete this clause</p>		N/A		
4.8.1	<p>General</p> <p>After second list, add the following: NOTE: Refer to the Consumer Goods (Products Containing Button/Coin Batteries) Safety Standard 2020 and Consumer Goods (Products Containing Button/Coin Batteries) Information Standard 2020 for more information on button cell batteries in Australia.</p>	No such parts.	N/A		
5.4.10.2.1	<p>General</p> <p>Delete the first paragraph and replace with the following: In Australia, the separation is checked by the test given in both Clause 5.4.10.2.2 and Clause 5.4.10.2.3. In New Zealand, the separation is checked by the test given in either 5.4.10.2.2 or 5.4.10.2.3.</p>	No external circuit (telecommunication network circuit) in this equipment.	N/A		
Table 28	Delete Table 28 and replace with the following:		N/A		
	Parts	Impulse test	Steady state test		
		New Zealand	Australia		
		New Zealand	Australia		
	Parts indicated in Clause 5.4.10.1 a) ^a	2.5 kV	7.0 kV for hand-held telephones and headsets, 2.5 kV for other equipment.	1.5 kV	3 kV
	Parts indicated in Clause 5.4.10.1 b) and c) ^b	1.5 kV ^c		1.0 kV	1.5 kV
<p>^a Surge suppressors shall not be removed.</p> <p>^b Surge suppressors may be removed, provided that such devices pass the impulse test of Clause 5.4.10.2.2 when tested as components outside the equipment.</p> <p>^c During this test, it is allowed for a surge suppressor to operate and for a sparkover to occur in a GDT.</p>					

IEC62368_1E - ATTACHMENT

Clause	Requirement + Test	Result - Remark	Verdict
5.4.10.2.2	<p><i>Delete</i> "NOTE" and <i>replace</i> with "NOTE 1". After NOTE 1, <i>add</i> the following: NOTE 2: For Australia, the 7 kV impulse simulates lightning surges on typical rural and semi-rural network lines. NOTE 3: For Australia, the value of 2.5 kV for Clause 5.4.10.1 a) was chosen to ensure the adequacy of the insulation concerned and does not necessarily simulate likely overvoltages.</p>	This equipment does not contain any external circuit.	N/A
5.4.10.2.3	<p><i>Delete</i> "NOTE" and <i>replace</i> with "NOTE 1". After NOTE 1, <i>add</i> the following: NOTE 2: For Australia, where there are capacitors across the insulation under test, it is recommended that d.c. test voltages are used. NOTE 3: The 3 kV and 1.5 kV values for Australia have been determined considering the low frequency induced voltages from the power supply distribution system.</p>	This equipment does not contain any external circuit.	N/A
6	Electrically-caused fire	Refer to below:	N/A
6.6	<p>After Clause 6.6, <i>add</i> the new Clauses 6.201 as follows: 6.201 External power supplies, docking stations and other similar devices (see special national conditions)</p>		N/A
8.6	Stability of equipment		N/A
Table 36	Footnote ^a , after first sentence, <i>add</i> the following: Equipment having displays with moving images shall include "television sets and display devices".	Replaced, the equipment is not a TV set.	N/A
8.6.1	<p>After Clause 8.6.1 <i>add</i> the following new clauses: 8.6.201 Restraining Device fixing point (see special national conditions) 8.6.202 Restraining device (see special national conditions)</p>	Replaced, the equipment is not a TV set.	N/A
Annex F Paragraph F.3.3.4	<p>Rated Voltage <i>Delete</i> "NOTE" and <i>replace</i> with NOTE1" After NOTE 1, <i>add</i> the following Equipment that is intended for connection to the supply mains in Australia and New Zealand shall be marked with: (a) A rated voltage of: <ul style="list-style-type: none"> • 230 V for single phase equipment • 400 V for poly phase equipment Or (b) A rated voltage range that includes: <ul style="list-style-type: none"> • 230 V for single phase equipment • 400 V for poly phase equipment NOTE 2: equipment that is not rated as above is not suitable for direct connection to the supply mains in Australia or new Zealand.</p>		P

IEC62368_1E - ATTACHMENT

Clause	Requirement + Test	Result - Remark	Verdict
Annex F.3.3.5	After the list, <i>add</i> the following Equipment that is intended for connection to supply mains in Australia or New Zealand shall be marked with a rated frequency of 50 Hz or a rated frequency range or nominal value which includes 50Hz		P
Annex F.3.8	After “The DC output of an external power supply”, insert “or docking stations and other similar external devices”		N/A
Annex G Paragraph G.4.2	Mains connectors 1 After “IEC 60320”, insert “or AS/NZS 60320 series”. 2 After “IEC 60906-1”, insert “or AS/NZS 3123” 3 <i>After</i> first paragraph <i>add</i> the following: 10 A or 15 A 250 V flat pin plugs for the connection of equipment to mains-powered socket-outlets for household or similar general use shall comply with AS/NZS 3112 or AS/NZS 60884.1.		P
Paragraph G.5.3.1	Transformers, General 1 Third dashed point <i>replace</i> ‘IEC 61558-1 and the relevant parts of IEC 61558-2’ with ‘AS/NZS 61558-1 and the relevant parts of AS/NZS 61558.2’ 2 Fourth dashed point <i>replace</i> ‘IEC 61558-2-16’ with ‘AS/NZS 61558.2.16’.		N/A
Annex G.7.1	Mains supply cords, General Fourth dashed paragraph, <i>replace</i> ‘IEC 60320-1’ with ‘AS/NZS 60320.1’		P
Table G.7	Sizes of conductors 1 First column, second row, <i>delete</i> “6” and <i>replace</i> with “7.5” 2 Second column, second row, <i>delete</i> ‘0,75’ and <i>replace</i> with ‘0.75 ^b ’ 3 <i>Delete</i> NOTE 1. 4 <i>Replace</i> ‘NOTE 2’ with ‘NOTE:’. 5 <i>Delete</i> ‘Footnote b’ and <i>replace</i> with the following: ^b This nominal cross-sectional area is only allowed for Class II appliances if the length of the power supply cord, measured between the point where the cord, or cord guard, enters the appliance, and the entry to the plug does not exceed 2 m (0.5 mm ² three-core supply flexible cords are not permitted; see AS/NZS 3191). 6 Footnote c <i>replace</i> ‘IEC 60320-1’ with ‘AS/NZS 60320.1’ 7 Footnote d <i>replace</i> ‘IEC 60320-1’ with ‘AS/NZS 60320.1’		P
Annex M M.2.1	<i>Add</i> “IEC 60086-2” to the list		P

IEC62368_1E - ATTACHMENT

Clause	Requirement + Test	Result - Remark	Verdict
Annex M Paragraph M.3.2	Test method Delete "NOTE" and replace with "NOTE 1" After NOTE 1 <i>add</i> the following: NOTE 2: In cases where the voltage source is provided by power from an unassociated power source, consideration should be given to the effects of possible single fault conditions in the unassociated equipment. If the power source is unknown then it should be assumed that the maximum limit of ES1 may be applied to the source input under assumed single fault conditions in the source when assessing the charging circuit in the equipment under test.	Battery voltage source from dedicated supply.	N/A
	Special national conditions (if any)		—
6.201	External power supplies, docking stations and other similar devices For external power supplies, docking stations and other similar devices, during and after abnormal operating conditions and during single fault conditions the output voltage— (a) at all ES1 outlets or connectors shall not increase by more than 10 % of the output rated voltage under normal operating conditions, measured after 3 s of introducing a single fault condition and after 3 s of introducing abnormal operating conditions; and (b) of a USB outlet or connector shall not increase by more than 3 V or 10 % of the output rated voltage under normal operating conditions, whichever is higher, measured after 3 seconds of introducing a single fault condition and after 3 s of introducing abnormal operating conditions For equipment with multiple rated voltages at the output, the requirements apply with the equipment configured for each output rated voltage in turn NOTE: This is intended to reduce the possibility of battery fire or explosion in attached equipment or accessories when charging secondary lithium batteries. The 3 s measurement delay is based on IEC document 108/742/INF, <i>TC 108, Standards Interpretation Panel Question 15 — Output voltage</i> , in relation to similar requirements in IEC 62368-3:2017. Conformity shall be checked by measurement, taking into account the abnormal operating conditions of Annex B.3 and the simulated single fault conditions of Annex B.4.		N/A

IEC62368_1E - ATTACHMENT

Clause	Requirement + Test	Result - Remark	Verdict
<p>8.6.201</p>	<p>Restraining device fixing point Freestanding-capable MS2 and MS3 television sets and display devices shall be provided with a fixing point to facilitate the anchoring of the equipment from toppling</p> <p>The fixing point shall conform to Clause 8.7 where the fixing point uses a wall, ceiling or other structure mount. Alternatively, the fixing point shall be capable of withstanding a pull equal to the mass of the equipment in all directions without damage</p> <p>Instructions for installation or instructions for use shall be provided to specify correct use of the fixing point</p>		<p>N/A</p>
<p>8.6.202</p>	<p>Restraining device MS2 and MS3 television sets and display devices shall be provided with a restraining device and associated hardware to attach to the television set or display device.</p> <p>The restraining device shall be capable of withstanding a pull equal to the mass of the equipment in all directions.</p> <p>Instructions for installation or instructions for use shall be provided to specify correct use of the fixing point</p>		<p>N/A</p>

DRAFT

AS/NZS 3112:2017 Appendix J

Clause	Requirement + Test	Result - Remark	Verdict
--------	--------------------	-----------------	---------

<p align="center">ATTACHMENT TO TEST REPORT AS_NZS_3112:2017_+A1:2021 Appendix J AUSTRALIAN / NEW ZEALAND NATIONAL DIFFERENCES (Approval and test specification—Plugs and socket-outlets)</p>			
Differences according to	AS_NZS_3112:2017_Amendment 1:2021_Appendix J		
TRF template used:	IECEE OD-2020-F3, Ed. 1.1		
Attachment Form No.	AS_NZS_3112:2017_Appendix J		
Attachment Originator	JAS-ANZ		
Master Attachment	2022-06		
<p>Copyright © 2020 IEC System for Conformity Testing and Certification of Electrical Equipment (IECEE), Geneva, Switzerland. All rights reserved.</p>			
	<p>Note: AS/NZS 3112 is NOT covered by IECEE Accreditation for Testing / Reporting Please State Laboratory Accreditation for this Standard</p>		—
	Accreditation		—

J2	DEFINITION	—
J2.1	<p>Detachable plug portion A plug portion that is detachable from the equipment and with connections including the following standardized outputs and other contacts</p> <p>(a) Type A (see Figure J1): A detachable plug portion with a connection intended for plugging directly into equipment. The connection being via the equipment group 1 appliance inlet within the scope of AS/NZS 60320.1.</p> <p>(b) Type B (see Figure J2): A detachable plug portion with a non-standardized connection intended for plugging directly into equipment</p> <p>(c) Type C (see Figure J3): A detachable plug portion with a connection intended for use with an adaptor connected to a flexible cord so as to replicate a supply plug and flexible cord configuration. The connection being via a group 1 appliance outlet within scope of AS/NZS 60320.2.2, which is integral with the plug portion (AS/NZS 3112:2017)</p>	N/A
J2.2	Integral plug portion	N/A

AS/NZS 3112:2017 Appendix J

Clause	Requirement + Test	Result - Remark	Verdict
	A plug portion that is integral to the equipment enclosure and is not detachable (AS/NZS 3112:2017)		
J2.3	Plug portion A plug portion is that portion of equipment with pins for insertion into a socket-outlet, including the plug pins, terminals of the plug pins, external dimensions of the 'maximum projection' and any connections of a detachable plug portion. (AS/NZS 3112:2017/A1:2021)		N/A

J3	REQUIREMENTS FOR THE PLUG PORTION		N/A
J3.1	General The following provisions apply to the dimensional and constructional requirements of plug portions of equipment and any detachable connection between the plug portion and the equipment:		N/A
(a)	For detachable plug portions intended for connection to the equipment in multiple orientations, the relevant tests are performed in the most onerous orientation.		N/A
(b)	For Type A detachable plug portion, the relevant requirements of AS/NZS 3105:2014 are applicable, in addition to conformance with relevant clauses of this Appendix		N/A
(c)	For Type B detachable plug portions, the conformance is shown by the relevant clauses of this Appendix.		N/A
(d)	For Type C detachable plug portions, conformance is shown by assessment to Section 2 of this Standard (plugs) and relevant clauses of this Appendix (AS/NZS 3112:2017)		N/A
J3.2	Plug pins of plug portions The requirements of Clause 2.2 are applicable for plug pins.		N/A

2.2	PLUG PINS		N/A
2.2.1	Current carrying parts of plug pins of metal having sufficient mechanical strength, electrical conductivity and resistance to corrosion adequate for the intended use		N/A

AS/NZS 3112:2017 Appendix J

Clause	Requirement + Test	Result - Remark	Verdict
--------	--------------------	-----------------	---------

	Plug pin material?		—
--	--------------------	--	---

2.2.3	Plug pins adequately proportioned throughout and portion adjacent to the connection designed to not introduce a stress concentration which may lead to a fracture of the pin, and suitably shaped to prevent abrasion or cutting of conductor strands due to flexure in normal use		N/A
	Exposed ends of plug pins have a lead-in, bevel or radius to facilitate entry into socket-outlets and to operate shutters		N/A
	Flat-pins with the following profile are deemed to comply:		—
(a)	Flat-pins with a radius on the end with side bevels may have a width and thickness profile as specified in Figure 2.1(h)		N/A
(b)	Flat-pins square on the end with corner and side bevels may have a width and thickness profile as specified in Figure 2.1(i)		N/A
(c)	Flat-pins square on the end with corner bevels and a radius on the sides may have a width and thickness profile as specified in Figure 2.1(j)		N/A
	Contact portion of the pins smooth and free from openings or indentations		N/A
	Flat pin plugs having a longitudinal seam or opening in the contact portion of one face; width not exceeding 0.3 mm and		N/A
	Thickness not exceeding 1.58 mm		N/A
	Exposed portion of earthing pins and pins other than insulated pins free from any non-metallic coverings or coatings (AS/NZS 3112:2017)		N/A
2.2.4	Live parts of insulated pin plugs not exposed when plug is partially or fully engaged with associated socket		N/A
	Compliance by measurement to Figure 2.4		N/A
	Lacquer, enamel or sprayed insulating coating not considered to be insulation material		N/A
	All live pins on low voltage plugs except for those shown in Figure 2.1 (a2), (b) and (g) of the insulated pin type		N/A
	Colour green or green / yellow not used for insulation of insulated pins		N/A

AS/NZS 3112:2017 Appendix J

Clause	Requirement + Test	Result - Remark	Verdict
--------	--------------------	-----------------	---------

	(AS/NZS 3112:2017)		
--	--------------------	--	--

J3.3	Ratings and dimensions for low-voltage plug portions Requirements of clauses 2.8.1 and 2.8.4 apply for rating and dimensions		N/A
------	--	--	-----

2.8	Ratings and Dimensions of Low Voltage Plugs		—
2.8.1	Plugs with ratings up to and including 20A; shall conform to the appropriate dimensions shown in Figure 2.1		N/A
	Rating of plug		—
	Nominal dimensions covering disposition of pins checked by gauge of Appendix A		N/A
	Distance between live pin and edge of moulding to not less than 9 mm		N/A
	Measured distance		—
	No point on plug face protrudes more than 0.5 mm		N/A
	Measured protrusion		—
	Dimensional requirements of Figure 2.1(e2) did not applied to plugs with greater than three pins (AS/NZS 3112:2017)		N/A
2.8.4	Low voltage plugs comply with dimensions of Figure 2.1		N/A
	Disposition of pins checked by gauge complying with Appendix A, B or F as appropriate		N/A
	Low voltage plug having rating up to 15A and of the Figure 2.1 (a1), (c), (d), (f) or (g) type; comply with dimensional requirements of Figure 2.1 (e1 and e2)		N/A
	20A plug of Figure 2.1 (a2) type complies with dimensional requirements of Figure 2.1 (e2)		N/A
	Plugs with insulated pins need not comply with dimension $R20.0 \pm 1$ mm requirement of Figure 2.1 (e3) provided there is at least 9mm from the edge of the live pins to the edge of the plug face Figure 2.1(e3). (AS/NZS 3112:2017)		N/A

J3.4	Internal connections for plug portions		N/A
------	---	--	-----

AS/NZS 3112:2017 Appendix J

Clause	Requirement + Test	Result - Remark	Verdict
	Requirements of clause 2.9 apply for internal connections, unless requirements contained in the relevant product standard (AS/NZS 3112:2017)		
2.9	INTERNAL CONNECTIONS		N/A
	Plug provided with earthing connections designed and constructed so that when plug is correctly wired and assembled:		N/A
(a)	Loose terminal screw or conductive material cannot bridge any live or earthed parts		N/A
(b)	Earthing parts effectively isolated from contact with live conductor which may become detached		N/A
(c)	Live parts effectively isolated from contact with any earthing conductor which may become detached		N/A
	Any connections for auxiliary devices comply with above requirements (AS/NZS 3112:2017)		N/A
J3.5	Arrangement of earthing connections for plug portions Requirements of clause 2.10 apply for arrangement of earthing connections		N/A
2.10	Arrangement of earthing connections		N/A
	Earthing pin radial to the circle embracing the pins (AS/NZS 3112:2017)		N/A
J3.6	Configuration of plug portions Requirements of clause 2.12.6 apply for configuration of the plug portion (AS/NZS 3112:2017)		N/A
2.12	Marking		—
2.12.6	Configuration of plugs		N/A
	Pins disposed so that configuration, as viewed from the pins, is earth, neutral and active in a clockwise direction		N/A
	Where there is no earthing pin; live pins conform to this configuration (AS/NZS 3112:2017)		N/A

AS/NZS 3112:2017 Appendix J

Clause	Requirement + Test	Result - Remark	Verdict
J4	Tests		—
J4.1	<p>General</p> <p>Plug portions of equipment shall be subjected to the following tests and unless stated otherwise, shall comply with the requirements specified in Section 2 for each test. The number of test samples shall be in accordance with Table J1</p> <p>For equipment with a detachable plug portion, the assessment(s) of Table J1 tests 2, 3, 5, 10 and 11 shall be conducted on the—</p> <p>(a) assembled equipment with the detachable plug portion connected; and</p> <p>(b) the detachable plug portion after it has been separated from the equipment</p> <p>(AS/NZS 3112:2017/A1:2021)</p>	N/A	
J4.2	<p>High voltage test</p> <p>The requirements of Clause 2.13.3 are applicable unless requirements are contained in the relevant product standard</p> <p>(AS/NZS 3112:2017)</p>	N/A	
2.13.3	Test No.1 - High voltage test		N/A
	<p>Plug withstands without failure electric strength test as specified</p> <p>(AS/NZS 3112:2017)</p>	(see appended table)	N/A
J4.3	Mechanical strength		N/A
J4.3.1	<p>Tumbling barrel test</p> <p>The tumbling barrel test is applied to determine the mechanical strength of the plug portions and equipment having integral or detachable plug portions.</p> <p>For equipment with a detachable plug portion, the detachable plug portion may become detached during the test. If this occurs the detachable plug portion shall be reassembled with the equipment when the pins are straightened as per (a) and (b) below.</p> <p>Three samples (Samples BCD in Table J1) that have not been subjected to any previous test are tested as specified in Clause 2.13.7.1, however the test is modified as follows:</p>		N/A

AS/NZS 3112:2017 Appendix J

Clause	Requirement + Test	Result - Remark	Verdict
	<p>They are tested in a tumbling barrel as described in AS 60068.2.32 or test Free fall repeated – Procedure 2 in IEC 60068-2.31.</p> <p>The samples shall be dropped from a height of 500 mm onto a steel plate, 3 mm thick.</p> <p>The barrel shall be turned at a rate of 5 r/min, to yield 10 falls per minute. Only one sample shall be tested at a time.</p> <p>A sample is dropped—</p> <p>(a) 500 times if the mass of the specimen does not exceed 250 g.</p> <p>The pins being straightened after each 100 drops and at the completion of the test to pass through the appropriate gauge of Figure A1, Figure B1 or Figure F1; and</p> <p>(b) 250 times if the mass of the specimen exceeds 250 g. The pins being straightened after each 25 drops and at the completion of the test to pass through the appropriate gauge of Figures A1, Figure B1 or Figure F1.</p> <p>(AS/NZS 3112:2017/A1:2021)</p>		N/A
	Mass of sample	_____ Grams	N/A
	Number of drops	500 / 250	N/A
	Compliance shall be checked by Paragraph J4.3.3	(See appended table)	N/A

J4.3.2	<p>Test No.3 Impact test.</p> <p>Plug portions and equipment having integral plug portions or detachable plug portions shall withstand lateral impact forces.</p> <p>All samples that were subjected to the tests in Paragraph J4.3.1 (Samples BCD in Table J1) shall be tested as follows:</p>		N/A
	<p>(a) The sample shall be positioned at the centre of a steel plate with a thickness of at least 6 mm. Apertures in the steel plate for the plug pins to pass through shall conform to the corresponding socket Standard. The sample shall be held against the steel plate by clamping all the pins.</p>		N/A
	<p>(b) Samples shall be subjected to blows, with an impact energy of 1.0 ± 0.05 J by any means having the same performance as the spring-operated impact-test apparatus of AS/NZS 3100.</p>		N/A
	<p>(c) Three blows shall be applied to every point that is most likely to directly or indirectly stress the enclosure joints of the sample</p>		N/A
	Compliance shall be checked by Paragraph J4.3.3		N/A

AS/NZS 3112:2017 Appendix J

Clause	Requirement + Test	Result - Remark	Verdict
--------	--------------------	-----------------	---------

J4.3.3	Specific compliance criteria This Paragraph provides the common compliance assessment criteria for tests specified in Paragraphs J4.3.1 and J4.3.2 .		N/A
	Following each test, the samples shall comply with Clause 2.13.7.1		N/A
(a)	assembled equipment with the detachable plug portion connected;		N/A
	After the test, samples show no damage	(See appended table)	N/A
(b)	the detachable plug portion after it has been separated from the equipment.		N/A
	After the test, samples show no damage	(See appended table)	N/A

4.3.4	Pin bending test The pins of the plug portion of three samples (Samples EFG in Table J1) not subjected to any previous tests shall be tested for compliance with the pin bending test of Clause 2.13.7.2 (AS/NZS 3112:2017/A1:2021)		N/A
-------	--	--	-----

2.13.7.2	Test No.4 – Pin bending test		N/A
	All flat-pin plugs rated up to and including 15 A shall be subjected to the pin bending test		N/A
	Three samples are subjected by clamping the plug in a rigid holding block and applying the bending force as specified		N/A
	After the test the pins shall not be broken off. (AS/NZS 3112:2017)		N/A

J4.8.3	Test No.5 Plug portion detachment requirements		N/A
	For all Type B or C devices and for Type A devices where the outlet of the detachable plug portion is parallel to the plug supply pins, disengagement of the detachable plug portion from the equipment shall require at least two simultaneous independent actions or the use of a tool.		N/A
	The plug portion and the equipment/adaptor shall be connected and disconnected 50 times (100 strokes).		N/A

AS/NZS 3112:2017 Appendix J

Clause	Requirement + Test	Result - Remark	Verdict
	Compliance is verified by the plugging test, a force which, over a period of 10 s, shall be increased steadily to 60 ±0.6 N and held at this value for a further 10 s, shall be applied evenly at the connecting equipment in a direction parallel to the pins. This procedure shall be conducted three times on the same plug portion, at intervals of 5 min, without disturbing the plug portions between tests		N/A
	During the test the plug portion shall not separate		N/A
	The test of AS/NZS 3112 'temperature rise test' for plugs shall be conducted immediately after the above test without disturbing the sample. Test No 6 Temperature Rise test J4.4 (AS/NZS 3112:2017/A1:2021)		N/A
J4.4	Temperature rise test The relevant requirements of Clause 2.13.8 are applicable for the temperature rise test, except that the test current shall be that specified in the relevant product standard		N/A
	The temperature rise of the pins shall not exceed 45 K irrespective of the temperature rise of parts specified in end-product standards.		N/A
	For detachable plug portions the temperature rise of terminals and contacts shall not exceed 45 K. (AS/NZS 3112:2017)		N/A
2.13.8	Test No.6 – Temperature rise test		N/A
	Plug tested in draught free environment as specified using clamping units as specified in Figure 2.10		N/A
	Test Current Relevant Product Standard		N/A
	Temperature of terminals and contacts of detachable plug portion not exceeding 45 K (AS/NZS 3112:2017)		N/A
J4.5	Securement of pins of the plug portion		N/A

AS/NZS 3112:2017 Appendix J

Clause	Requirement + Test	Result - Remark	Verdict
--------	--------------------	-----------------	---------

	The requirements of Clause 2.13.9 are applicable for the securement of pins. (AS/NZS 3112:2017)		
--	--	--	--

2.13.9	Test No.7. Securement of pins		N/A
2.13.9.1	Movement of pins		N/A
	Plug pins clamped 5 ± 0.5 mm from pin face; test equipment and sample pre-conditioning for 1 h at $40 \pm 1^\circ\text{C}$		N/A
	Force of 18 ± 1 N applied to pin 14 ± 0.5 mm from plug face; applied gradually over 10 s and maintained for 10 s; applied in four directions		N/A
	Maximum deflection during test not exceeding 2.0 mm		N/A
	Any distortion 5 minutes after test does not prevent insertion of plug into standard gauge(s) (AS/NZS 3112:2017 + A1:2021)		N/A
2.13.9.2	Fixing of pins		N/A
	Plug heated to $50 \pm 2^\circ\text{C}$ for 1h		N/A
	Force of 60 ± 0.6 N applied to each pin over 10 s and maintained for 10 minutes; applied in two directions along length of pin		N/A
	Maximum displacement during test not exceeding 2.4 mm		N/A
	Maximum measured displacement		—
	Pin returns to within 0.8 mm of nominal length within 5 minutes of removal of test force (AS/NZS 3112:2017)		N/A

J4.6	Tests on the insulation material of insulated pin-plug portions The requirements of Clause 2.13.13 are applicable for insulating material of insulated plug pins. (AS/NZS 3112:2017)		N/A
------	---	--	-----

2.13.13	Test No.8 Tests for insulation material of insulated pin plugs		N/A
2.13.13.1	Material of pin-insulation resistant to stresses at temperature likely to occur		N/A

AS/NZS 3112:2017 Appendix J

Clause	Requirement + Test	Result - Remark	Verdict
2.13.13.2	Pressure test at high temperature		N/A
	Specimen tested as per Figure 2.5 with force of 2.5 N applied as specified; maintained for 2 h at $160 \pm 5^\circ\text{C}$; removed and cooled by immersion in water within 10 s		N/A
	Thickness of insulation at point of impression not reduced by more than 50%		N/A
	Initial thickness		—
	Thickness after test		—
	No visible cracks on insulation material		N/A
	Dimension of insulating material not below minimum size in Figure 2.4 (AS/NZS 3112:2017)		N/A
2.13.13.3	Static damp heat test		N/A
	Specimen subjected to two damp heat cycles in accordance with IEC 60068-2-30; Db (12 + 12h), 95% RH, $25 \pm 3^\circ\text{C}$; 40°C		N/A
	After this treatment and recovery to room temperature; specimen subjected to:		N/A
(a)	Insulation resistance test in accordance with clause 2.13.2 (e)		N/A
(b)	High voltage test in accordance with clause 2.13.3		N/A
(c)	Abrasion test in accordance with clause 2.13.13.6		N/A
2.13.13.4	Low temperature test		N/A
	Plug maintained at $-15 \pm 2^\circ\text{C}$ for minimum of 24 h and returned to room temperature; after which specimen subjected to:		N/A
(a)	Insulation resistance test in accordance with clause 2.13.2 (e)		N/A
(b)	High voltage test in accordance with clause 2.13.3		N/A
(c)	Abrasion test in accordance with clause 2.13.13.6		N/A
2.13.13.5	Impact test at low temperature		N/A
	Specimen maintained at $-15 \pm 2^\circ\text{C}$ for 24 h		N/A
	Specimen placed in position and subjected to impact test as per Figure 2.6; mass of 100 ± 1 g falling through 100 mm		N/A

AS/NZS 3112:2017 Appendix J

Clause	Requirement + Test	Result - Remark	Verdict
	Four impacts applied; specimen rotated through 90° between impacts		N/A
	After return to room temperature; no visible cracks of insulating material		N/A
2.13.13.6	Abrasion test		N/A
	Plug held in clamp and tested as per Figure 2.7; pin loaded at 4 N; 20 000 movements		N/A
	After test; pins show no damage affecting safety or impairing further use of the plug		N/A
	Insulating sleeve not punctured or rucked up (AS/NZS 3112:2017)		N/A
J4.7	Test no.9 Equipment with a plug portion intended to be supported by the contacts of a socket-outlet		N/A
	Equipment with pins intended to be introduced into fixed socket-outlets not imposing undue strain on socket-outlet		N/A
	Applied torque not exceeding 0.25 Nm		N/A
	Measured torque (AS/NZS 3112:2017)		—
J4.8	Additional requirements for detachable plug portions		N/A
J4.8.1	Test no.10 Access to live parts		N/A
	Small test finger of Figure 13 of IEC 61032 was not possible to contact live parts with the force of 20N		N/A
	incorrectly assemble the plug portion was not possible (AS/NZS 3112:2017)		N/A
J4.8.2	Test No.11 Construction of detachable contacts where the input current of the equipment exceeds 0.2 A		N/A
	Contacts of the equipment shall be such that they make and maintain, under normal service conditions, satisfactory electrical and mechanical contact with the corresponding contact of the detachable plug portion.		N/A
	For connections intended to accommodate pins, contact shall be made on two surfaces diametrically opposite, except if a single spring-		N/A

AS/NZS 3112:2017 Appendix J

Clause	Requirement + Test	Result - Remark	Verdict
	assisted contact is used. (AS/NZS 3112:2017/A1:2021)		
	Contacts shall not rely exclusively on the resilience of the contact material and shall have an opposite face of material other than thermoplastic or resilient insulating material. (AS/NZS 3112:2017/ A1:2021)		N/A
	The alignment and contact-making properties of contacts shall be independent of terminal screws		N/A
	The effectiveness of the contacts shall be independent of pressure from any thermoplastic or resilient moulding.		N/A
	A visual inspection is conducted to determine the existence of interference between the metal contacts and the thermoplastic or resilient moulding to provide supplementary contact pressure to the metal contacts.		N/A
	Conformance of the effectiveness of the contacts is checked by inspection and by the inspection and tests in J4.8.3 (AS/NZS 3112:2017)		N/A
J4.8.4	Resistance of insulating material to heat and fire		N/A
J4.8.4.1	Test no.12 Resistance to heat For Type B detachable plug portions parts of non-metallic material, parts of insulating material supporting live parts including connections, and parts of thermoplastic material providing supplementary insulation or reinforced insulation, shall be sufficiently resistant to heat if their deterioration could cause the appliance to fail to comply with this Standard.		N/A
	Ball pressure test conducted in accordance with IEC 60695-10-2		N/A
(a)	75°C ± 2°C, for external parts;		N/A
(b)	125°C ± 2°C, for parts supporting live parts.		N/A
J4.8.4.2	Test no.13 Resistance to fire		N/A
	Plug portions comply with resistance to fire requirements of AS/NZS 3100 Annex A as follows:		N/A

AS/NZS 3112:2017 Appendix J

Clause	Requirement + Test	Result - Remark	Verdict
	The glow wire test temperature 'T' for 'retaining parts' of fixed socket outlets shall be 750 C (AS/NZS 3112:2017)		N/A

DRAFT

AS/NZS 3112:2017 Appendix J

Clause	Requirement + Test	Result - Remark	Verdict
--------	--------------------	-----------------	---------

TABLES OF RESULTS

2.2.4	TABLE: Dimensions of insulation on insulated pin plugs		N/A
Dimension (Figure 2.1 designation)	Measured (mm)	Allowed (mm)	
Phase pin		8.7 ± 0.5	
Neutral pin		8.7 ± 0.5	

2.8.1	TABLE: Dimensions of plugs- 10A (a1)		N/A
Dimension (Figure 2.1 designation)	Measured (mm)	Allowed (mm)	
Phase and neutral pin width (A)		6.35 ± 0.15	
Earth pin width (B)		6.35 ± 0.15	
Pin thickness (C)		1.63 + 0.15, -0.05	
Pin disposition (D)		checked by test gauge	
Pin disposition (E)		checked by test gauge	
Phase and neutral pin length (F)		17.06 ± 0.4	
Earth pin length (G)		19.94 ± 0.8	
Pin boss radius - maximum		21.0 max	
Pin boss height		8.6 min	

2.8.1	TABLE: Dimensions of plugs- 15A (a1)		N/A
Dimension (Figure 2.1 designation)	Measured (mm)	Allowed (mm)	
Phase and neutral pin width (A)		6.35 ± 0.15	
Earth pin width (B)		9.08 ± 0.15	
Pin thickness (C)		1.63 + 0.15, -0.05	
Pin disposition (D)		checked by test gauge	
Pin disposition (E)		checked by test gauge	
Phase and neutral pin length (F)		17.06 ± 0.4	
Earth pin length (G)		19.94 ± 0.8	
Pin boss radius - maximum		21.0 max	
Pin boss height		8.6 min	

AS/NZS 3112:2017 Appendix J

Clause	Requirement + Test	Result - Remark	Verdict
--------	--------------------	-----------------	---------

2.8.1	TABLE: Dimensions of plugs-20A (a2)	N/A	
Dimension (Figure 2.1 designation)	Measured (mm)	Allowed (mm)	
Phase and neutral pin width (A)		9.08 ± 0.15	
Earth pin width (B)		9.08 ± 0.15	
Pin thickness (C)		1.63 + 0.15, -0.05	
Pin disposition (D)		checked by test gauge	
Pin disposition (E)		checked by test gauge	
Phase and neutral pin length (F)		17.06 ± 0.4	
Earth pin length (G)		19.94 ± 0.8	
Pin boss radius - maximum		21.0 max	
Pin boss height		8.6 min	

2.8.1	TABLE: Projection from plug face centroid	N/A	
Direction of projection	Measured (mm)	Allowed (mm)	
Left		≤ 21.9 or ≥ 27.0	
Right		≤ 21.9 or ≥ 27.0	
Up		≤ 21.9 or ≥ 27.0	
Down		≤ 21.9 or ≥ 27.0	

2.13.3	TABLE: Test No. 1 – High voltage test	N/A	
Test voltage applied between:	Test voltage (V)	Breakdown	
All poles of the plug; taken in pairs	1000	Yes / No	
Live poles of the plug and any external metal	3500	Yes / No	
Live poles of the plug and the earthing terminal	1000	Yes / No	
Live poles of the plug and a flexible electrode	3500	Yes / No	
Live poles and metal foil applied around insulation on pins	1250	Yes / No	

2.13.7.1	Test No.2 – Tumbling barrel test	N/A	
	Following the test, the samples shall comply with Clause 2.13.7.1(a..e)	N/A	
	(a) Live parts shall not have become exposed to the standard test finger	N/A	

AS/NZS 3112:2017 Appendix J

Clause	Requirement + Test	Result - Remark	Verdict
	(b) For earth pins, the resistance of the plug/socket-outlet circuit shall be such that conformance with Clause 3.14.7 is maintained. AS/NZS 3100 Cl 8.5 The resistance shall not exceed 0.1 Ω		—
	(c) Any other function affecting safety shall not be impaired		N/A
	(d) No live part shall have become detached or loosened, to the extent that a hazardous situation is created (see Clause 2.9)		N/A
	(e) The pins shall be inspected with normal, or corrected to normal, vision. Insulation may be removed if necessary. Pins shall not be broken or show cracking		N/A

	Test No.3 Impact test for assembled equipment with the detachable plug portion connected and for equipment with an integral plug portion.		N/A
	Following the test, the samples shall comply with Clause 2.13.7.1 (a..e) as follows:		N/A
	(a) Live parts shall not have become exposed to the standard test finger (Figure 8.10 in AS/NZS 3100 or Test Probe B in IEC 61032)		N/A
	(b) For earth pins, the resistance of the plug/socket-outlet circuit shall be such that conformance with Clause 3.14.7 is maintained so that the resistance between the earthing terminal of any socket-outlet provided with an earthing contact and the earthing terminal of the plug used for testing shall be of a low resistance. Compliance is by the test of earthing connection in AS/NZS 3100 Clause 8.5. The resistance shall not exceed 0.1 Ω		—
	(c) Any other function affecting safety shall not be impaired		N/A
	(d) No live part shall have become detached or loosened, to the extent that a hazardous situation is created		N/A

AS/NZS 3112:2017 Appendix J

Clause	Requirement + Test	Result - Remark	Verdict
	(e) The pins shall be inspected with normal, or corrected to normal, vision. Insulation may be removed if necessary. Pins shall not be broken or show cracking.		N/A
	Following the test, the samples shall conform to the 'Guarding of live parts' requirements of AS/NZS 3100:2015 cl 5.1 as follows:		N/A
	Except for equipment intended for use only in a position not accessible to unauthorized persons, all equipment shall be so designed and constructed that, when the equipment is standing, supported, or fixed, in a normal manner, no person can inadvertently come into contact with any live part		N/A
	If a hole giving access to preset controls is marked as such on the enclosure or reference made to it in the instructions and the setting of this control requires a screwdriver or other tool, the adjustment of the control shall not allow contact with any live parts. A metal test pin having a diameter of 2 mm and a length of 100 mm shall not become live when it is inserted through the hole in every position with a force of 10 N.		N/A
	In addition, the opening or removal of any cover or component, with or without tools, where such opening or removal is necessary as a normal operation of the equipment as distinct from maintenance, repairs, or adjustment, shall not expose live parts to inadvertent personal contact.		N/A
	Any metal cover or casing enclosing live parts shall be of a strength sufficient to ensure that it cannot be deformed readily so as to come into contact with live parts.		N/A
	Compliance is checked by inspection, test and checking that live parts shall not have become exposed to the standard test finger (Figure 8.10 in AS/NZS 3100 or Test Probe B in IEC 61032)		N/A
	Class II equipment and class II constructions shall be constructed and enclosed so that there is adequate protection against accidental contact with basic insulation and metal parts separated from live parts by basic insulation only.		N/A
	It shall only be possible to touch parts which are separated from live parts by double insulation or reinforced insulation.		N/A
	Compliance is checked by application of the standard test finger (Figure 8.10 in AS/NZS 3100 or Test Probe B in IEC 61032)		N/A

AS/NZS 3112:2017 Appendix J

Clause	Requirement + Test	Result - Remark	Verdict
	Following the test, the samples shall conform to the 'Separation of live parts from non-current-carrying conductive parts' requirements of AS/NZS 3100.CI 5.2.2 as follows:		N/A
	The support and insulation of every live part shall be such as will ensure that no live part can make contact with any non-current-carrying conductive part exposed to personal contact.		N/A
	In respect of terminals of components such as switches, adequate clearances shall be maintained or insulation shall be provided to prevent contact of the terminals, or loose strands of flexible cords intended to be terminated therein, with exposed conductive parts. Where necessary, provision shall be made to ensure that conductors protruding through terminals, when normally connected, will not contact exposed conductive parts.		N/A
	Compliance is checked by inspection.		N/A

	Test No.3 Impact test for the detachable plug portion after it has been separated from the equipment		—
	Following the test, the samples shall comply with Clause 2.13.7.1 (a..e)		N/A
	(a) Live parts shall not have become exposed to the standard test finger (Figure 8.10 in AS/NZS 3100 or Test Probe B in IEC 61032)		N/A
	(b) For earth pins, the resistance of the plug/socket-outlet circuit shall be such that conformance with Clause 3.14.7 is maintained so that the resistance between the earthing terminal of any socket-outlet provided with an earthing contact and the earthing terminal of the plug used for testing shall be of a low resistance. Compliance is by the test of earthing connection in AS/NZS 3100 Clause 8.5. The resistance shall not exceed 0.1 Ω		N/A
	(c) Any other function affecting safety shall not be impaired		N/A
	(d) No live part shall have become detached or loosened, to the extent that a hazardous situation is created		N/A

AS/NZS 3112:2017 Appendix J

Clause	Requirement + Test	Result - Remark	Verdict
	(e) The pins shall be inspected with normal, or corrected to normal, vision. Insulation may be removed if necessary. Pins shall not be broken or show cracking.		N/A
	Following the test, the samples shall conform to the 'Guarding of live parts' requirements of AS/NZS 3100:2015 cl 5.1 as follows:		N/A
	Except for equipment intended for use only in a position not accessible to unauthorized persons, all equipment shall be so designed and constructed that, when the equipment is standing, supported, or fixed, in a normal manner, no person can inadvertently come into contact with any live part		N/A
	If a hole giving access to preset controls is marked as such on the enclosure or reference made to it in the instructions and the setting of this control requires a screwdriver or other tool, the adjustment of the control shall not allow contact with any live parts. A metal test pin having a diameter of 2 mm and a length of 100 mm shall not become live when it is inserted through the hole in every position with a force of 10 N.		N/A
	In addition, the opening or removal of any cover or component, with or without tools, where such opening or removal is necessary as a normal operation of the equipment as distinct from maintenance, repairs, or adjustment, shall not expose live parts to inadvertent personal contact.		N/A
	Any metal cover or casing enclosing live parts shall be of a strength sufficient to ensure that it cannot be deformed readily so as to come into contact with live parts.		N/A
	Compliance is checked by inspection, test and checking that live parts shall not have become exposed to the standard test finger (Figure 8.10 in AS/NZS 3100 or Test Probe B in IEC 61032)		N/A

AS/NZS 3112:2017 Appendix J

Clause	Requirement + Test	Result - Remark	Verdict
	Class II equipment and class II constructions shall be constructed and enclosed so that there is adequate protection against accidental contact with basic insulation and metal parts separated from live parts by basic insulation only.		N/A
	It shall only be possible to touch parts which are separated from live parts by double insulation or reinforced insulation.		N/A
	Compliance is checked by application of the standard test finger (Figure 8.10 in AS/NZS 3100 or Test Probe B in IEC 61032)		N/A
	Following the test, the samples shall conform to the 'Separation of live parts from non-current-carrying conductive parts' requirements of AS/NZS 3100.CI 5.2.2 as follows:		N/A
	The support and insulation of every live part shall be such as will ensure that no live part can make contact with any non-current-carrying conductive part exposed to personal contact.		N/A
	In respect of terminals of components such as switches, adequate clearances shall be maintained or insulation shall be provided to prevent contact of the terminals, or loose strands of flexible cords intended to be terminated therein, with exposed conductive parts. Where necessary, provision shall be made to ensure that conductors protruding through terminals, when normally connected, will not contact exposed conductive parts.		N/A
	Compliance is checked by inspection.		N/A

2.13.8	TABLE: Test No. 6 - Temperature rise test		N/A
	Ambient temperature	°C	
	Test current	A	
Measured part		dT measured (K)	dT allowed (K)
Active (phase) terminal			45
Neutral terminal			45
Earthing terminal			45

AS/NZS 3112:2017 Appendix J

Clause	Requirement + Test	Result - Remark	Verdict
--------	--------------------	-----------------	---------

2.13.9.1	TABLE: Movement of pins		N/A
	Earth and neutral pins clamped – phase pin loaded		
	Force direction	Measured deflection (mm)	Allowed deflection (mm)
	Force towards neutral plane parallel to pin plane		2.0
	Force from neutral plane parallel to pin plane		2.0
	Force outwards at 90° to pin plane		2.0
	Force inwards at 90° to pin plane		2.0

2.13.9.1	TABLE: Movement of pins		N/A
	Phase and neutral pins clamped – earth pin loaded		
	Force direction	Measured deflection (mm)	Allowed deflection (mm)
	Force inwards parallel to pin plane		2.0
	Force outwards parallel to pin plane		2.0
	Force towards neutral		2.0
	Force towards phase		2.0

2.13.9.1	TABLE: Movement of pins		N/A
	Phase and earth pins clamped – neutral pin loaded		
	Force direction	Measured deflection (mm)	Allowed deflection (mm)
	Force towards phase plane parallel to pin plane		2.0
	Force from phase plane parallel to pin plane		2.0
	Force outwards at 90° to pin plane		2.0
	Force inwards at 90° to pin plane		2.0

2.13.13.3	TABLE: Test No.13(b) – Insulation resistance test after static damp heat test		N/A
	Applied between:	Insulation resistance (MΩ)	Minimum required (MΩ)
	Live poles and metal foil applied around insulation on pins		5

AS/NZS 3112:2017 Appendix J

Clause	Requirement + Test	Result - Remark	Verdict
--------	--------------------	-----------------	---------

2.13.13.3	TABLE: Test No.1 – High voltage test after static damp heat test		N/A
Test voltage applied between:		Test voltage (V)	Breakdown
Live poles and metal foil applied around insulation on pins		1250	Yes / No

2.13.13.4	TABLE: Test No.1 – Insulation resistance test after low temperature test		N/A
Applied between:		Insulation resistance (MΩ)	Minimum required (MΩ)
Live poles and metal foil applied around insulation on pins			5

2.13.13.4	TABLE: Test No.1 – High voltage test after low temperature test		N/A
Test voltage applied between:		Test voltage (V)	Breakdown
Live poles and metal foil applied around insulation on pins		1250	Yes / No

J4.8.4.1	TABLE: Test no.12 Resistance to heat		N/A
Component tested		Temperature (°C)	Diameter of impression (mm)

Conformance is checked by subjecting the relevant part to the ball pressure test of IEC 60695-10-2.

J4.8.4.2	TABLE: Test no.13 Resistance to Fire		N/A
Plug portions shall comply with the requirements for resistance to fire in accordance with AS/NZS 3100:2017 Annex A. The glow-wire test temperature 'T' shall be 750°C.			N/A

Glow-wire testing was conducted in accordance with IEC 60695-2-11.

Test specimens arranged so that the surface in contact with the tip of the glow-wire was vertical and glow wire tip applied to surface of the specimen likely to be subjected to thermal stresses in normal use.

A layer of white pine board and wrapping tissue was placed beneath the sample at 200mm ± 5mm distance.

Duration of flaming or glowing after tip removal (max. allowable 30 s) (s)								
Surrounding parts burned away completely (not permitted)								
Ignition of wrapping tissue layer (not permitted)								
RESULTS If parts tested withstand the glow-wire test, but during the test produce a flame that persists for longer than 2 s, then the consequential needle flame test of AS/NZS 3100:2017 Annex A 6.1.5 applies.								

- LEGEND:
- | | | |
|------------------------------|-----------------------------------|--------------------------------------|
| CE Complete Equipment | SA Sub Assembly | SE Self Extinguished |
| EBD Emitted Burning Droplets | SBD Specimen Burned and Distorted | SMD Specimen Melted and Distorted |
| ME Manually Extinguished | SC Separate Component | SS Specimen Scorched |
| NA Not Applicable | SCC Specimen Completely Consumed | WPNI Wall Penetrated but no Ignition |
| NI No Ignition | X Flame Appeared for an Instant | |

AS/NZS 3112:2017 Appendix J

Clause	Requirement + Test	Result - Remark	Verdict
--------	--------------------	-----------------	---------

TABLE: Needle- flame test (NFT)					N/A
Object/ Part No./ Material	Manufacturer/ trademark	Duration of application of test flame (ta); (s)	Ignition of specified layer Yes/No	Duration of burning (tb) (s)	Verdict

Supplementary information:
 - NFT not relevant (or applicable) for Parts of material classified as V-0 or V-1
 - NFT not relevant (or applicable) for Base material of PCBs classified as V-0 or if relevant VTM-0

-- End of Attachment 3 --

DRAFT

IEC62368_1E - ATTACHMENT

Clause	Requirement + Test	Result - Remark	Verdict
--------	--------------------	-----------------	---------

Attachment 4 CHINA NATIONAL DIFFERENCES

<p align="center">ATTACHMENT TO TEST REPORT IEC 62368-1 CHINA NATIONAL DIFFERENCES (Audio/video, information and communication technology equipment -Part 1: Safety requirements)</p>			
Differences according to : GB 4943.1-2022			
TRF template used: : IECEE OD-2020-F3, Ed. 1.1			
Attachment Form No. : CN_ND_IEC62368_1E			
Attachment Originator : CQC			
Master Attachment..... : Dated 2022-12-01			
Copyright © 2020 IEC System for Conformity Testing and Certification of Electrical Equipment (IECEE), Geneva, Switzerland. All rights reserved.			
	National Differences		—
4.1.2	<p>Use of components Add a paragraph: A component used shall comply with related requirements corresponding altitude of the equipment.</p>		P
4.11	<p>Add clause 4.11,as follows: Protection in PRIMARY CIRCUITS against overcurrent short-circuits and earth faults shall be provided as an integral part of the equipment except the device shall meet the all requirement of Fault conditions.</p> <p>If pluggable equipment type B or permanently connected equipment depends on protective devices outside the equipment for protection, this shall be stated in the installation instructions of the equipment, with requirements for short-circuit protection, over-current protection, or both if necessary.</p>		N/A
5.3.2.2	<p>Contact requirements Amend the 2nd paragraph of table 8 to be: For equipment intended to be used at altitude of 2000m to 5000m, the values in this table are multiplied by the multiplication factor corresponding altitude of 5000m.</p>		P



IEC62368_1E - ATTACHMENT

Clause	Requirement + Test	Result - Remark	Verdict
5.4.2.5	<p>Multiplication factors for altitudes higher than 2 000 m above sea level</p> <p>Amend the 1st paragraph to be:</p> <p>For equipment to be operated at more than 2000 m above sea level and up to 5000m above sea level, the minimum CLEARANCE in tables 10,11 and 14, and resistance test voltages required in table 15, shall meet the requirements of 5000 m above sea level, This is multiplied by the multiplication factor corresponding altitude of 5000m in table 16.</p> <p>For equipment to be used at equal or less than 2000 m above sea level, the minimum CLEARANCE in tables 10, 11 and 14, and resistance test voltages required in table 15, shall meet the requirements of 2000 m above sea level. This is multiplied by the multiplication factor corresponding altitude of 2000m in table 16.</p> <p>Delete note 2 of Clause 5.4.2.5.</p>		P
5.4.5.1	<p>General</p> <p>Delete the 2nd paragraph of Clause 5.4.5.1: This test does not apply to equipment where one antenna terminal on the equipment is connected to earth in accordance with 5.6.7.</p> <p>Add the following:</p> <p>The Insulation resistance between CATV antenna coaxial sockets and protective earth of apparatus shall comply with BASIC INSULATION. If it's possible that CLASS II apparatus with CATV antenna coaxial sockets connect with protective earth of another CLASS I apparatus by other terminals, the insulation resistance between them shall comply with BASIC INSULATION as well.</p> <p>If antenna cable separated from the protective earth before connection to the apparatus, there is no requirements of Insulation resistance between them but F.4 requirements shall be meet.</p> <p>Delete "NOTE" of Clause 5.4.5.1</p>		P

IEC62368_1E - ATTACHMENT

Clause	Requirement + Test	Result - Remark	Verdict
5.4.8	<p>Humidity conditioning</p> <p>Amend clause 5.4.8 as follows:</p> <p>The humidity conditioning is conducted for 120 h in a cabinet or room containing air with ambient temperature (40±2) °C and a relative humidity of (93±3)%. During this conditioning, the component or subassembly is not energized.</p> <p>For equipment not to be operated at tropical climatic conditions, humidity conditioning is conducted for 48 h in a cabinet or room containing air with a relative humidity of (93±3) %. The temperature of the air, at all places where samples can be located, is maintained within 2 °C of any convenient value between 20 °C and 30 °C such that condensation does not occur.</p> <p>Add note: For equipment to be operated at 2000 m - 5000m above sea level, assessment and requirement of humidity conditioning for Insulation material properties are considered.</p> <p>Pre-processing conditions and requirements below 2000m can be used until additional data is available.</p>		P
6.4.9 Y.4.3	Delete references to ASTM and NEMA.		N/A
6.5.1	<p>General requirements</p> <p>Delete the text of the Note “Wire complying with UL 2556 VW-1 is considered to comply with these requirements”.</p>		P
F.1	Amend the second paragraph of annex F.1 to be: Unless symbols are used or otherwise specified, safety related equipment markings, instructions, and instructional safeguards shall be in normative Chinese.	Should be considered when marketing into China.	N/A

IEC62368_1E - ATTACHMENT

Clause	Requirement + Test	Result - Remark	Verdict
F.2.2	<p>After the first paragraph of annex F.2.2 ,add the following:</p> <p>For apparatus intended to be used at altitude not exceeding 2000m, a warning label containing the following or a similar appropriate wording or a symbol shown below shall fixed to the equipment at readily visible place. "Only used at altitude not exceeding 2000m." </p> <p>For apparatus intended to be used in not-tropical climate regions, a warning label containing the following or a similar appropriate wording or a symbol shown below shall fixed to the equipment at readily visible place. "Only used in not-tropical climate regions." </p> <p>If only symbol used, the explanation of the symbol shall be contained in the instruction manual.</p> <p>The statements above shall be given in a language acceptable to the regions where the apparatus is intended to be used.</p>	Should be considered when marketing into China.	N/A
F.3.3.4	<p>After the last paragraph, Added:</p> <p>...for single rated voltage, "220 V" or three-phase "380V" shall be marked only. For a rating voltage range, 220 V or three-phase 380V shall be covered. For multiple rated voltages, one of them shall be 220 V or three-phase 380V and which default setting from manufacture shall be 220 V or three-phase 380V as well.</p>		N/A
F.3.3.5	<p>After the last paragraph, Added:</p> <p>Rated frequency shall be 50Hz or frequency range shall cover 50Hz.</p>		P
F.4	<p>Instructions</p> <p>Added:</p> <ul style="list-style-type: none"> - For apparatus incorporating antenna coaxial sockets which is non-separated with CATV network, a warning wording or a similar shall be given in the instruction manual: "A CATV cable intended to be connected to apparatus shall be separated with the protective earth of the apparatus, otherwise fire hazard might be caused." 	No such part.	N/A
F.5	<p>Instructional safeguards</p> <p>In table F.2 , change 230V to 220V , change 400Y/230V 3Ø to 380 Y/220 V 3Ø</p>		N/A

IEC62368_1E - ATTACHMENT

Clause	Requirement + Test	Result - Remark	Verdict
G.4.2	<p>Amend clause G.4.2 as follows:</p> <p>Plugs connected to the MAINS in apparatus shall comply with GB/T 1002,GB/T 1003,GB/T 2099.1 or GB/T11918 (All parts) series.</p> <p>Appliance coupler shall comply with GB/T 17465 (All parts) series or GB/T 11918 (All parts) series.</p>		N/A
Special national conditions (if any)			—
0.12	<p>Add clause 0.12</p> <p>Description of relevant information.</p>		N/A
1	<p>GB 4943.1-2022 applies to equipment used at altitudes not exceeding 5000m above sea level, For apparatus intended to be used at altitude not exceeding 2000m, The requirements can be appropriately reduced, but warning instructions shall be provided.</p> <p>Revise the sixth paragraph of 1 as:</p> <p>In addition to specified by the manufacturer, this document assumes a maximum altitude of 5000m</p>	Should be considered when marketing into China.	N/A
B.2.6.1	<p>Amend T_{ma} as follows:</p> <p>T_{ma} is the maximum ambient temperature permitted by the manufacturer's specification, or 35 °C, whichever is greater.</p> <p>Add note 1: For equipment not to be operated at tropical climatic conditions, T_{ma} is the maximum ambient temperature permitted by the manufacturer's specification, or 25 °C, whichever is greater.</p> <p>Add note 2: For equipment to be operated at 2000m-5000m above sea level, its temperature test conditions and temperature limits are under consideration. temperature test conditions and temperature limits below 2000m can be used until additional data is available.</p>		P
Annex Z (normative)	<p>Added annex Z:</p> <p>Instructions of the new safety warning labels.</p>	Should be considered when marketing into China.	N/A
Annex AA (informative)	<p>Added annex AA:</p> <p>Illustration relative to safety explanation in normative Chinese, Tibetan, Mongolian, Zhuang Language and Uighur.</p>	Should be considered when marketing into China.	N/A

IEC62368_1E - ATTACHMENT

Clause	Requirement + Test	Result - Remark	Verdict
--------	--------------------	-----------------	---------

Attachment 5 Japan National Differences

<p>ATTACHMENT TO TEST REPORT IEC 62368-1:2018 JAPAN NATIONAL DIFFERENCES Audio/video, information and communication technology equipment – Part 1: Safety requirements</p>			
<p>Differences according to.....: J62368-1(2023)</p>			
<p>TRF template used:: IECEE OD-2020-F3:2022, Ed. 1.2</p>			
<p>Attachment Form No......: JP_ND_IEC62368_1E</p>			
<p>Attachment Originator: UL Solutions (JP)</p>			
<p>Master Attachment: Dated 2023-05-12</p>			
<p>Copyright © 2023 IEC System for Conformity Testing and Certification of Electrical Equipment (IECEE), Geneva, Switzerland. All rights reserved.</p>			
<p>National Differences</p>			
<p>4.1.2</p>	<p>Where the component, or a characteristic of a component, is a safeguard or a part of a safeguard, components shall comply with the requirements of this document or, where specified in a requirements clause, with the safety aspects of the relevant JIS component standards or IEC component standards, or components shall have properties equivalent to or better than these.</p>		<p>P</p>
<p>5.6.1</p>	<p>Mains socket-outlet and interconnection coupler shall comply with Clause G.4.2A if they are incorporated as part of the equipment.</p>	<p>No such part.</p>	<p>N/A</p>

IEC62368_1E - ATTACHMENT

Clause	Requirement + Test	Result - Remark	Verdict
5.6.2.1	<p>Connection for protective conductor of class 0I equipment provided with instructional safeguard in accordance with Clause F.3.6.1A is considered to make earlier and break later than supply connection.</p> <p>Mains plug having a lead wire for protective earthing connection of class 0I equipment shall comply with all of the following:</p> <ul style="list-style-type: none"> – Not to be used for equipment having a rated voltage of 150 V or more – Clip is not used for the earthing connection of the lead wire. – The lead wire for earthing is at least 10 cm long <p>If class 0I equipment provides an independent main protective earthing terminal and is intended to be installed by ordinary person, earthing wire shall be provided in the package of the equipment.</p>	Not class 0I equipment.	N/A
5.6.2.2	Internal earthing conductor of the cord set that is covered by the sheath of mains cord and is formed together with mains plug and appliance connector need not be green-and-yellow.		N/A
5.6.3	<p>In case of class 0I equipment using power supply cord having two conductors (no earthing conductor), the conductor of protective earthing lead wire shall comply with either of the following:</p> <ul style="list-style-type: none"> – use of annealed copper wire with 1.6 mm diameter or corrosion-inhibiting metal wire having size and strength that are equivalent to or more than the above copper wire – single core cord or single core cable with 1.25 mm² or more cross-sectional area 	Not class 0I equipment.	N/A
5.7.3	For class 0I equipment that is provided with mains socket-outlet in the configuration as specified in JIS C 8282 series, JIS C 8300 or JIS C 8303, or that is provided with mains appliance outlet as specified in JIS C 8283 series for the purpose of interconnection, the measurement is conducted on the system of the interconnected equipment having a single connection to the mains.	Not class 0I equipment.	N/A
5.7.5	In case of class 0I equipment, touch current shall not exceed 1.41 mA peak or for sinusoidal wave, 1.0 mA r.m.s. when measured using the network specified in Figure 4 of IEC 60990:2016.	Not class 0I equipment.	N/A

IEC62368_1E - ATTACHMENT

Clause	Requirement + Test	Result - Remark	Verdict
6.4.3.2	<p>A fuse complying with JIS C 6575 series or a fuse having equivalent characteristics shall open within 1 s.</p> <p>A fuse having time/current characteristics other than those specified in IEC 60127 shall be tested with the characteristics taken into account. In case of Class A fuse of JIS C 6575, replace “2.1 times” by “1.35 times” and in case of Class B fuse of JIS C 6575, replace “2.1 times” by “1.6 times”.</p>		P
8.5.4.3.1	<p>Only three-phase stationary equipment rated more than AC 200 V can be considered as being for use in locations where children are not likely to be present, when complying with Clause F.4.</p>		N/A
8.5.4.3.2	<p>For equipment installed where children may be present, an instructional safeguard shall be provided by easily understandable wording in accordance with Clause F.5, except that element 3 is optional.</p>		N/A
8.5.4.3.4	<p>The media destruction device is tested according to Clause V.1.2 with applicable jointed test probes to the opening. And then the wedge probe per Figure V.4 shall not contact any moving part.</p>	No such parts	N/A
8.5.4.3.5	<p>The wedge probe of Figure V.4 and applicable jointed test probes specified in Clause V.1.2 shall not contact any moving part.</p> <p>Instructional safeguard shall not be used instead of equipment safeguard for preventing access to hazardous moving parts.</p>	No such parts	N/A
F.3.5.1	<p>When the mains socket-outlet is configured in accordance with JIS C 8282 series, JIS C 8300 or JIS C 8303, the assigned current or power shall be marked. If the voltage of the socket-outlet is the same as the mains voltage, the voltage need not be marked.</p> <p>Instructional safeguard of Class 0I equipment shall be provided with an instructional safeguard in accordance with Clause F.5 when a mains socket-outlet as specified in JIS C 8282 series, JIS C 8300 or JIS C 8303 to which class I equipment can be connected is provided in accordance with Clause G.4.2A except for the cases where the socket-outlet is accessible only to skilled persons.</p>	No such parts	N/A
F.3.5.3	<p>If the fuse is necessary for the safeguard function, the symbols indicating pre-arcing time-current characteristic shall be included.</p>	No such parts	N/A

IEC62368_1E - ATTACHMENT

Clause	Requirement + Test	Result - Remark	Verdict
F.3.6.1A	<p>Marking for class 0I equipment</p> <p>The requirements of Clauses F.3.6.1.1 and F.3.6.1.2 shall be applied to class 0I equipment.</p> <p>For class 0I equipment, a marking of instructions shall be provided regarding the earthing connection.</p> <p>In addition to the above, for class 0I equipment, an instruction to connect earthing before and disconnect earthing after the connection of supply conductors shall be marked on the visible place of the main body or shall be in the text of an accompanying document.</p>	Not class 0I equipment.	N/A
F.3.6.2	<p>Symbols, IEC 60417-5172 (2003-02) or IEC 60417-6092 (2011-10), shall not be used for class I equipment or class 0I equipment.</p>	No such parts.	N/A
F.3.8A	<p>Attention marking for aging deterioration of CRT television</p> <p>Year of manufacture, standard usage period by design according to JIS C 9921-5 and cautionary statement for possible risks of aging deterioration when used beyond the specified period shall be marked on CRT television except for industrial use CRT television.</p>	No such parts.	N/A
F.4	<p>For audio equipment with terminals classified as ES3 in accordance with Table E.1, and for other equipment with terminals marked in accordance with F.3.6.1 and F.3.6.1A, the instructions shall require that the external wiring connected to these terminals shall be installed by a skilled person, or shall be connected by means of ready-made leads or cords that are constructed in a way that would prevent contact with any ES3 circuit.</p> <p>For class 0I equipment provided with independent main protective earthing terminal, where the cord for the protective earthing connection is not provided in the package of the equipment, if the protective earthing connection is made by instructed person or skilled person, the suitable installation instruction for the protective earthing connection shall be provided.</p>	No such parts.	N/A
G.3.2.1	<p>The thermal link when tested as a separate component, shall comply with the requirements of JIS C 6691 or have properties equivalent to or better than that.</p>	No such parts.	N/A

IEC62368_1E - ATTACHMENT

Clause	Requirement + Test	Result - Remark	Verdict
G.3.4	<p>Except for devices covered by Clause G.3.5, overcurrent protective devices used as a safeguard shall comply with the applicable JIS or IEC standard in accordance with 4.1.2 or shall have equivalent or better properties.</p> <p>Such a protective device shall have adequate breaking (rupturing) capacity to interrupt the maximum fault current (including short-circuit current) that can flow.</p>	No such parts.	N/A
G.4.1	This requirement does not apply to connectors covered in Clauses G.4.2 and G.4.2A.	No such parts.	N/A
G.4.2	<p>Mains connectors, mains plugs and socket-outlets shall comply with JIS C 8283 series, JIS C 8285, IEC 60309 series, JIS C 8282 series, JIS C 8300, JIS C 8303, or have equivalent or better properties.</p> <p>A power supply cord set provided with appliance connector that can fit appliance inlet complying with JIS C 8283-1 shall comply with JIS C 8286.</p> <p>Construction shall prevent mechanical stress not to transmit to the soldering part of appliance inlet terminal.</p> <p>When an equipment is rated not more than 125 V and all of the following are met, Type C14 and C18 appliance inlet complying with JIS C 8283-3 can be considered as rated 15 A.</p> <ul style="list-style-type: none"> – The temperature of appliance inlet does not exceed the value specified in JIS C 8283-1 under the most unfavourable normal operating condition as specified in Clause B.2.1. – "Use only designated cord set attached in this equipment" or equivalent text is described in the operating instruction. If the cord set is not provided in the package of the equipment, suitable information regarding to the cord set is described in the operating instruction. 	No such parts.	N/A
G.4.2A	Mains socket-outlet and interconnection coupler provided with the class II, class I and class 0I equipment respectively	No such parts.	N/A
G.7.1	A mains supply cord need not include the protective earthing conductor for class 0I equipment provided with independent protective earthing conductor.	No such parts.	N/A
G.7.2 Table G.7	Cross-sectional area of equipment rated up to and including 3 A shall be 0.75 mm ² .	No such parts.	N/A

IEC62368_1E - ATTACHMENT

Clause	Requirement + Test	Result - Remark	Verdict
G.7.6.1 Table G.9	<p>The cross-sectional area of mains cords according to JIS C 3010 may comply with relevant Japanese wiring regulation.</p> <p>For cables other than those complying with JIS C 3662 series or JIS C 3663 series, the terminals shall be suitable for the size of the intended cables.</p>	No such parts.	N/A

-- End of Attachment 5 --

DRAFT

IEC62368_1E - ATTACHMENT			
Clause	Requirement + Test	Result - Remark	Verdict

Attachment 6 SAUDI ARABIA NATIONAL DIFFERENCES

ATTACHMENT TO TEST REPORT IEC 62368-1:2018 SAUDI ARABIA NATIONAL DIFFERENCES (Audio/video, information and communication technology equipment Part 1: Safety requirements)	
Differences according to	National standard SASO-IEC 62368-1:2020
TRF template used:	IECEE OD-2020-F3, Ed. 1.1
Attachment Form No.	SA_ND_IEC62368_1E
Attachment Originator	SASO
Master Attachment	2022-12-22
Copyright © 2022 IEC System for Conformity Testing and Certification of Electrical Equipment (IECEE), Geneva, Switzerland. All rights reserved.	
	National Differences

	Plugs used for pluggable equipment comply with standard SASO-2203.	Must be considered when enter this country.	N/A
--	Frequency (Hz)		N/A
	60 Hz		N/A
--	Rated voltage (V)		N/A
	Single phase 230 V Three phase 400 V		N/A

-- End of Attachment 6 --

Attachment 7 Photographs

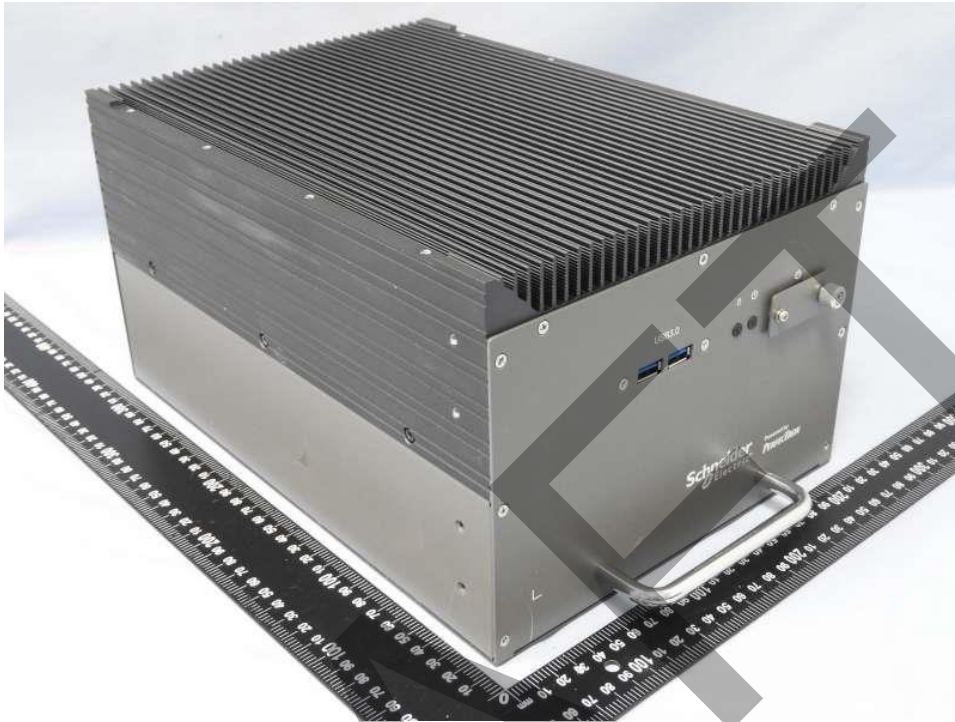

External view



External view



External view



External view



External view

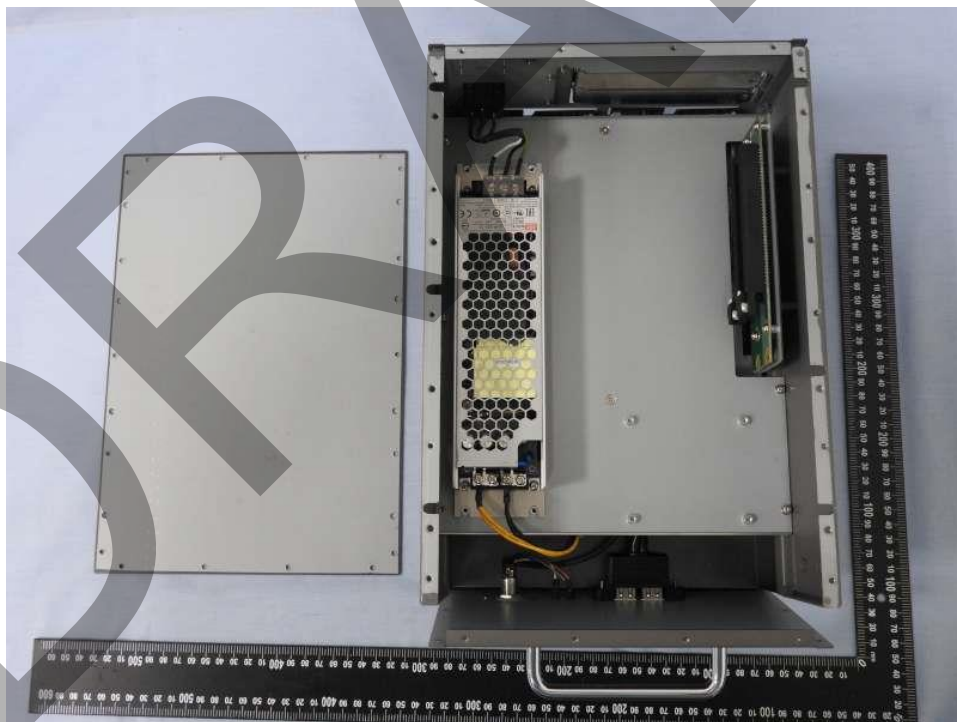

Internal view

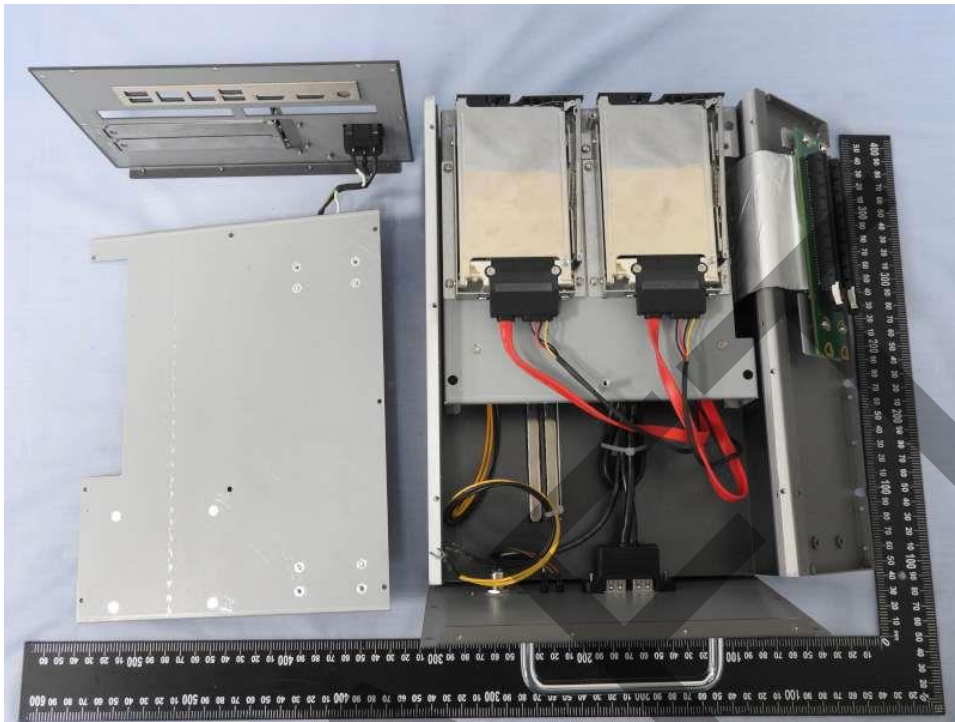

Internal view

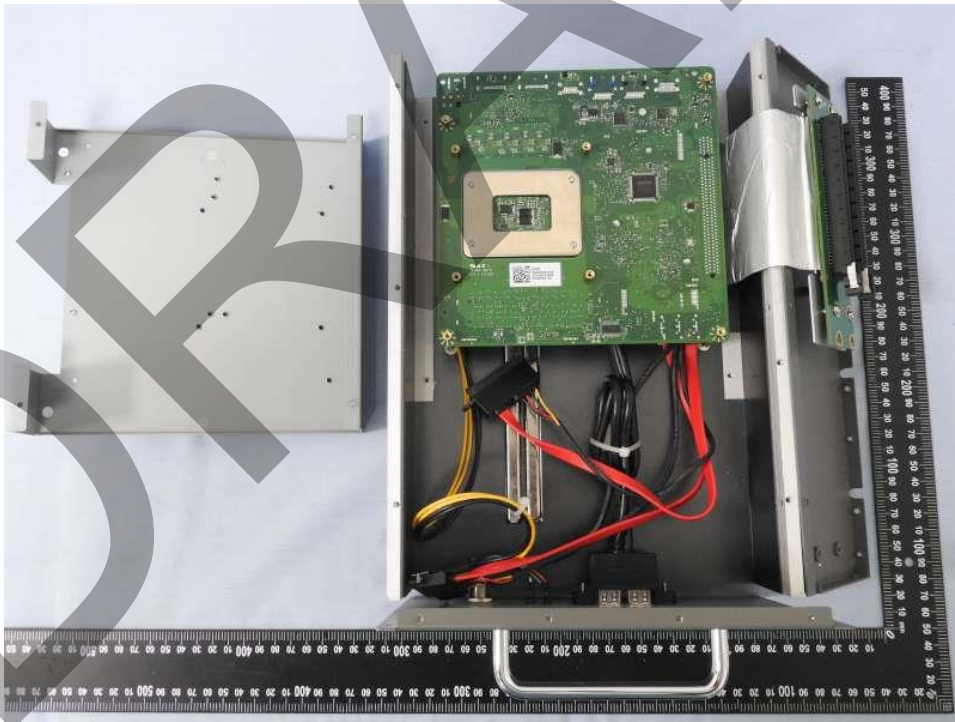

Internal view

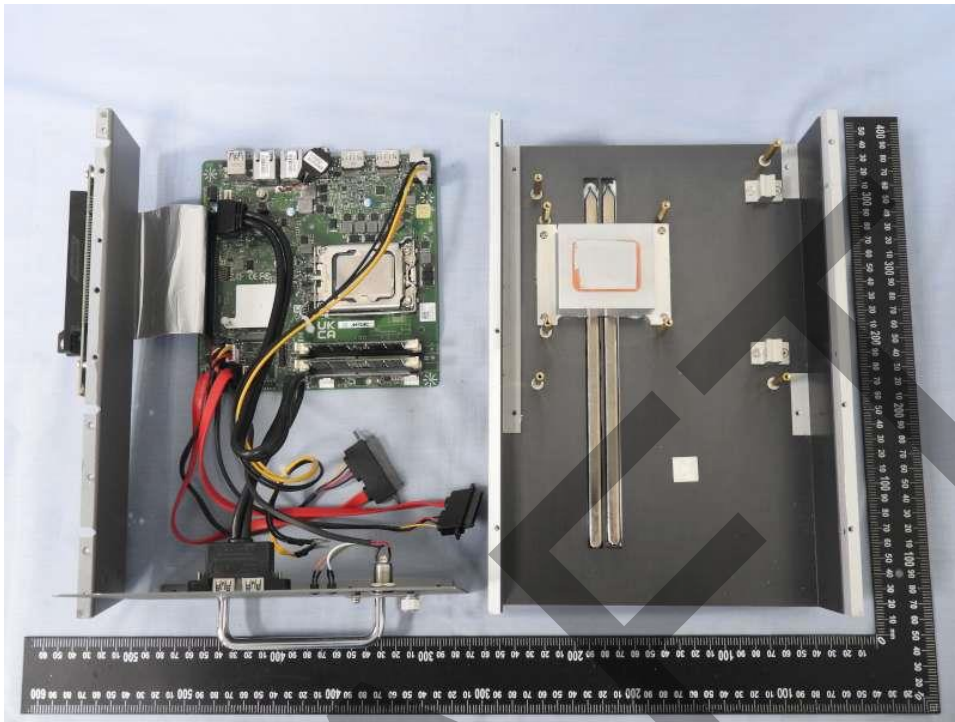

Internal view



Internal view

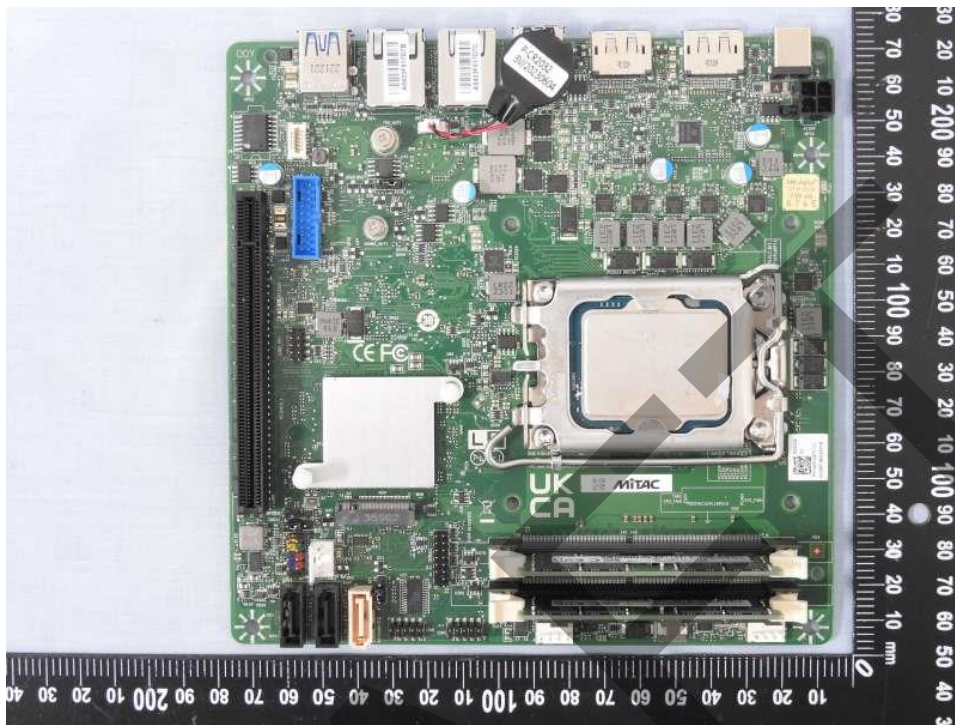

Main board

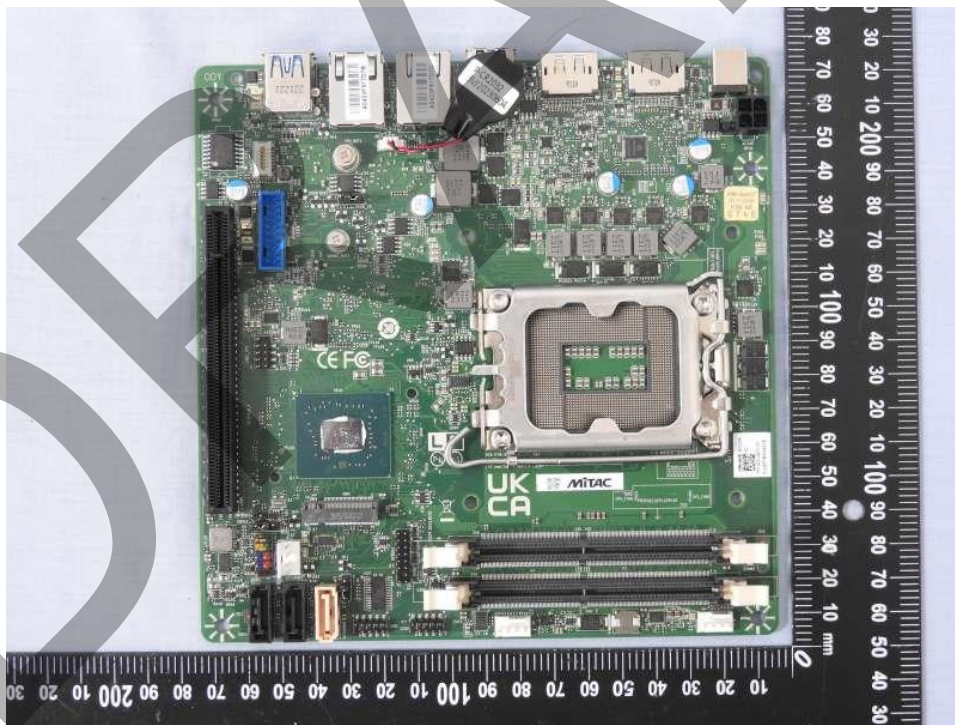

Main board



Main board



Riser board