



# AV800-027

# A4554

IP65 MILITARY ICE LAKE D-2796NT,  
10GSFP, 10G BASE-T GPU SERVER



- Designed to meet MIL-810, MIL-461 EMC/EMI
- MIL-STD-810 Thermal, Shock, Vibration, Humidity
- Intel® Xeon D-2796NT 20 cores 2.0GHz Max Turbo 3.1GHz.
- NVIDIA RTX A4500 5888 CUDA cores PCIe Gen 4.0 x16.
- 1 x 10GbE SFP28 LAN Port+1x RJ45 10GbE base-T port+ 2 x RJ45 1GbE base-T
- M.2 NVMe 2TB (R/W, 7150/5250 MB/sec)
- 2 x U.2 NVMe 8TB
- Hardware with Swappable Cage
- Extreme Temperature -20°C~60°C
- Dimensions: 405 x 316 x 204.8 mm
- IP65 Sealed with External Cooling Blade
- Power 18V~36V DC Input



## Introduction

Artificial intelligence (AI) is quickly becoming one of the most crucial elements of business success.

Today, deploying powerful computing platforms that can accelerate and scale their AI-based products and services while adapting them to harsh environments has become vital for many successful military applications.

7Starlake is innovating to address the emerging high-throughput inference market driven by IoT devices which are generating huge amounts of data. The combination of

NVIDIA CUDA parallel Processor cores and the new architecture-based GeForce Accelerator is an ideal combination for demanding and latency-sensitive workloads.



## MAIN FEATURE

- Ultra High Performance Intel® Xeon Ice Lake-D, D-2796NT (20 Cores)
- NVIDIA MXM-GPU Quadro RTX A4500 5888 CUDA
- MIL-STD-810 Thermal, Vibration, Shock, Humidity
- 1 x 10GbE SFP28, 1 x 10GbE RJ45, 2 x 1GbE RJ45
- 64GB (Up to 512GB LRDIMM/256GB RDIMM)
- 2 x NVMe PCIe Gen 4.0 U.2, 1 x NVMe PCIe Gen4 M.2
- Dual Removable Anti-Drop U.2 Solid-State Disk
- IP65 Sealed with External Cooling Blade
- MIL-STD-810 Thermal, Shock, Vibration, Humidity
- MIL-STD 461 EMI/EMC
- Power 18V~36V DC-IN
- Extreme Temperature Support -20°C ~+60°C

# Block Diagram

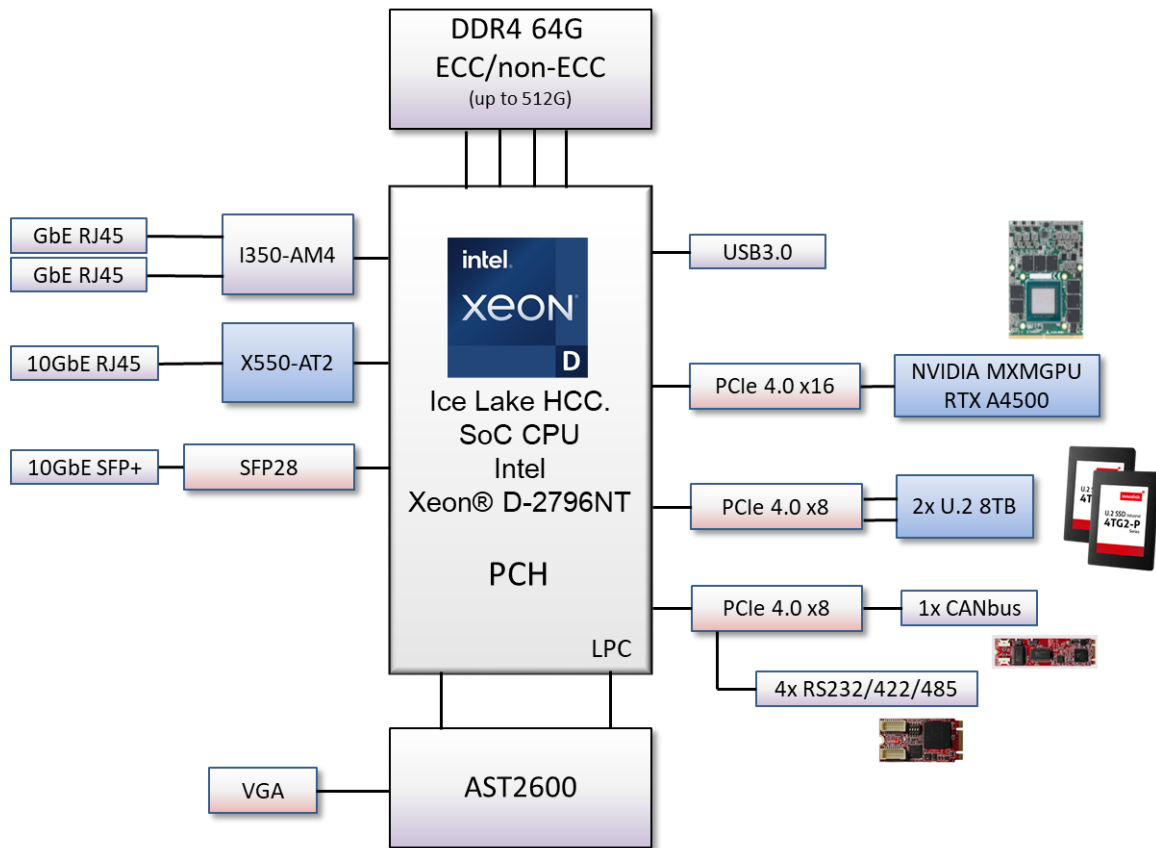

## MIL-STD Environment

- Operating Temperature High: 50°C, MIL-STD-810G, Method 501.5, Procedure I
- Operating Temp Low: 0°C, MIL-STD-810G, Method 502.5, Procedure I
- Non-Operating Temperature High: 70°C, MIL-STD-810G, Method 501.5, Procedure II
- Non-Operating Temperature Low: -40°C, MIL-STD-810G, Method 502.5, Procedure II
- Operating Altitude: Up to 15,000ft., MIL-STD-810G, Method 500.5
- Non-Operating Altitude: Up to 45,000ft., MIL-STD-810G, Method 500.5
- Humidity: MIL-STD-810G, Method 507.5., Procedure Ib (Natural Cycle B3)
- Shock: MIL-STD-810G, Method 516.6, 30g's, Saw-tooth, 11ms & MIL-DTL-901E Grade A., Class II., Type B
- Vibration: MIL-STD-167, Type I, Deck Mounted Equipment
- EMI/EMC: MIL-STD-461F, RE101, RE102, (Shipboard Level 1), RS103, CE101, CE102, CS101, CS114, CS116
- Airborne Noise: MIL-STD-740-1 compliance: 43.7dBA (Idle), 52.5dBA(50%), 54.6dBA(80%)

# Specifications

## SYSTEM

CPU	Intel® Xeon® D-2796NT, 20 core, 40 thread, 30MB Cache, 2.0GHz Max Turbo up to 3.1GHz Single socket FCBGA-2579, up to 120W TDP
Memory type	64GB RDIMM ECC DDR4-3200/2933 MHz
Chipset	Intel® SoC Integrated
GPU	1x MXM NVIDIA® RTX A4500, 5888 CUDA Cores, PCIe Gen4.0 x16
Display	VGA, Resolution up to 1920x1200@60Hz 32bpp
Chipset	Aspeed AST2600 BMC
Ethernet Controller	25G SFP28 LAN via SoC 10G LAN via Intel® X550 Gigabit LAN via Intel®i350
LAN	2x 1GBase-T , 1x 10GBase-T LAN, 1x 10GBase SFP+
Storage	2 x 8TB, 2.5" U.2 SSD hot-swap 1 x 2TB, NVMe M.2 2280 by PCIe
Power Type	18V~36V DC Input
Dimensions	405mm x 316mm x 204.8mm (W x L x H)

## FRONT I/O

X1	1 x CAN BUS TVS07RF-9-98S connector
X2	1 x10GbE(SFP+) LCFTV70NN connector
X3	1 x 10GbE TVS07RF-11-35SA connector
X4	1 x DC-IN TV07RW-13-4P connector
X5	4 x RS232/422/485 24FD35SN connector
X6	1 x GbE TVS07RF-11-35S-LC connector
X7	1 x GbE TVS07RF-11-35S-LC connector
X8	1 x USB3.0 USB3FTV7AZNF312 connector
X9	1 x VGA D-sub 15 connector with waterproof cap

## OPERATING SYSTEM

Operating System	Ubuntu 20.04.6
RoHS	RoHS compliant

## ENVIRONMENTAL

MIL-STD-810 Test	<p>Method 500.5, Procedures I and II (Altitude, Operation): 12,192M, (40,000 ft) for the initial cabin altitude (18.8Kpa or 2.73 Psia)</p> <p>Method 500.5, Procedures III and IV (Altitude, Non-Operation): 15,240, (50,000 ft) for the initial cabin altitude (14.9Kpa or 2.16 Psia)</p> <p>Method 501.5, Procedure I (Storage/High Temperature)</p> <p>Method 501.5, Procedure II (Operation/High Temperature)</p> <p>Method 502.5, Procedure I (Storage/Low Temperature)</p> <p>Method 502.5, Procedure II (Operation/Low Temperature)</p> <p>Method 503.5, Procedure I (Temperature shock)</p> <p>Method 507.5, Procedure II (Temperature &amp; Humidity)</p> <p>Method 509.7 Salt Spray (50±5)g/L</p> <p>Method 514.6, Vibration Category 24/Non-Operating (Category 20 &amp; 24,Vibration)</p> <p>Method 514.6, Vibration Category 20/Operating (Category 20 &amp; 24,Vibration)</p> <p>Method 516.6, Shock-Procedure V Non-Operating (Mechanical Shock)</p> <p>Method 516.6, Shock-Procedure I Operating (Mechanical Shock)</p>
Reliability	<p>Conduction Cooling.</p> <p>Designed &amp; Manufactured using ISO 9001 Certified Quality Program.</p>
MIL-STD-461	<p>CE102 basic curve, 10kHz - 30 MHz</p> <p>RE102-4, (1.5 MHz) -30 MHz - 5 GHz</p> <p>RS103, 200 MHz - 3.2 GHz, 50 V/m equal for all frequencies</p> <p>EN 61000-4-2: Air discharge: 8 kV, Contact discharge: 6kV</p> <p>EN 61000-4-3: 10V/m</p> <p>EN 61000-4-4: Signal and DC-Net: 1 kV</p> <p>EN 61000-4-5: Leads vs. ground potential 1kV, Signal und DC-Net: 0.5 kV</p> <p>CE and FCC</p>
MIL-STD-1275	<p>Steady State – 20V~33V,</p> <p>Surge Low – 18V/500ms,</p> <p>Surge High – 100V/500ms</p> <p>Emitted spikes</p> <p>Injected Voltage surges</p> <p>Emitted voltage surges</p> <p>Voltage ripple (2V)</p> <p>Voltage spikes</p> <p>Starting Operation</p> <p>Reverse polarity</p>
Operating Temp.	-20°C to +60°C
Storage Temp.	-40°C to +85°C
Relative Humidity	5% to 95%, non-condensing

## Dimensions

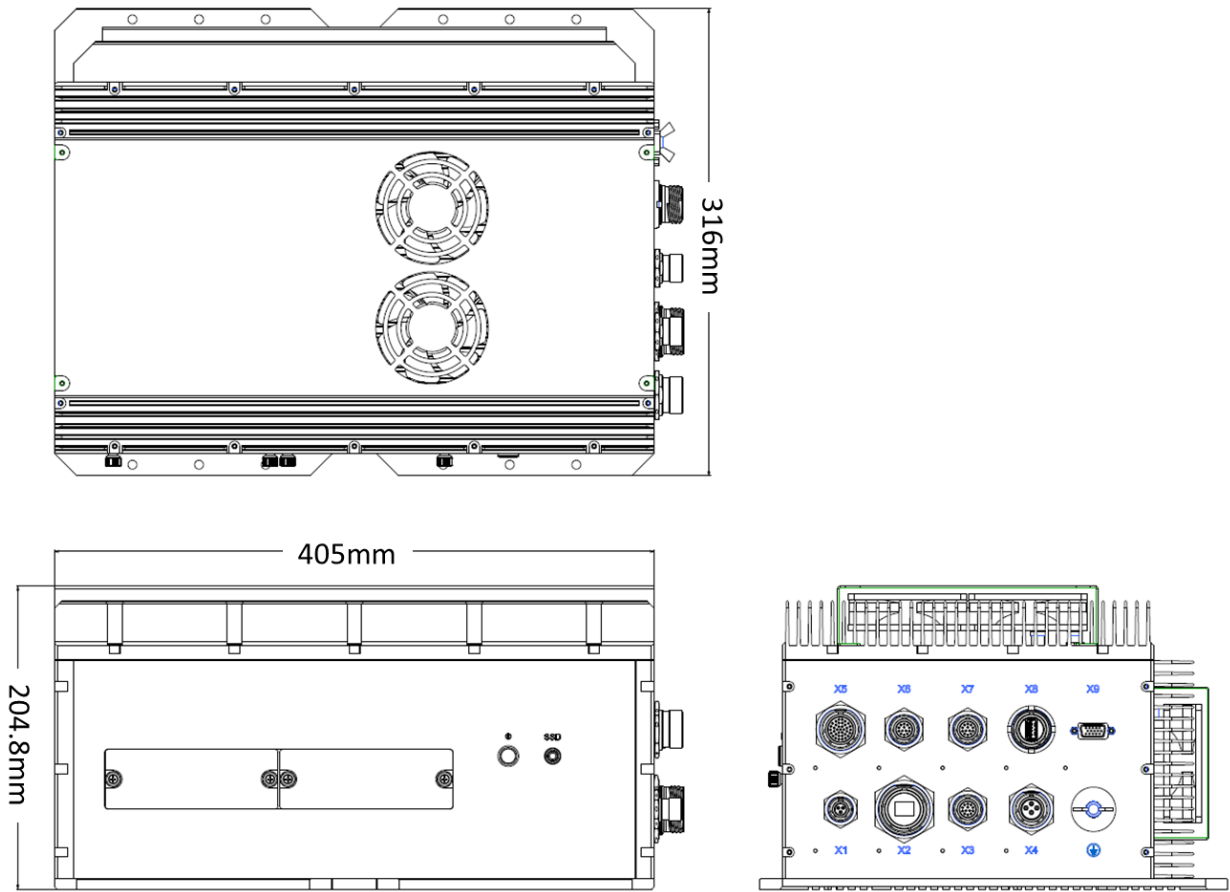

## Ordering Information

<b>Model</b>	AV800-D27-A45S4
<b>Type</b>	Rugged
<b>CPU</b>	Intel Xeon D-2796NT
<b>Memory</b>	64GB RDIMM ECC DDR4-3200/2933 MHz
<b>GPU</b>	1x MXM embedded NVIDIA RTX™ A4500
<b>Storage 1</b>	M.2 NVMe 2TB Gen4 x4
<b>Storage 2</b>	2 x U.2 PCIe Gen4 x4 (8TB) with swappable cage
<b>Expansion</b>	1x CAN bus
	4x RS232/422/485
<b>LAN</b>	1x 10GbE (SFP+) + 1x 10GbE + 2x GbE LAN
<b>Power</b>	18V~36V DC Input
<b>Dimension</b>	405 x 316 x 204.8mm (W x D x H)